

BRIC

Owner's Manual

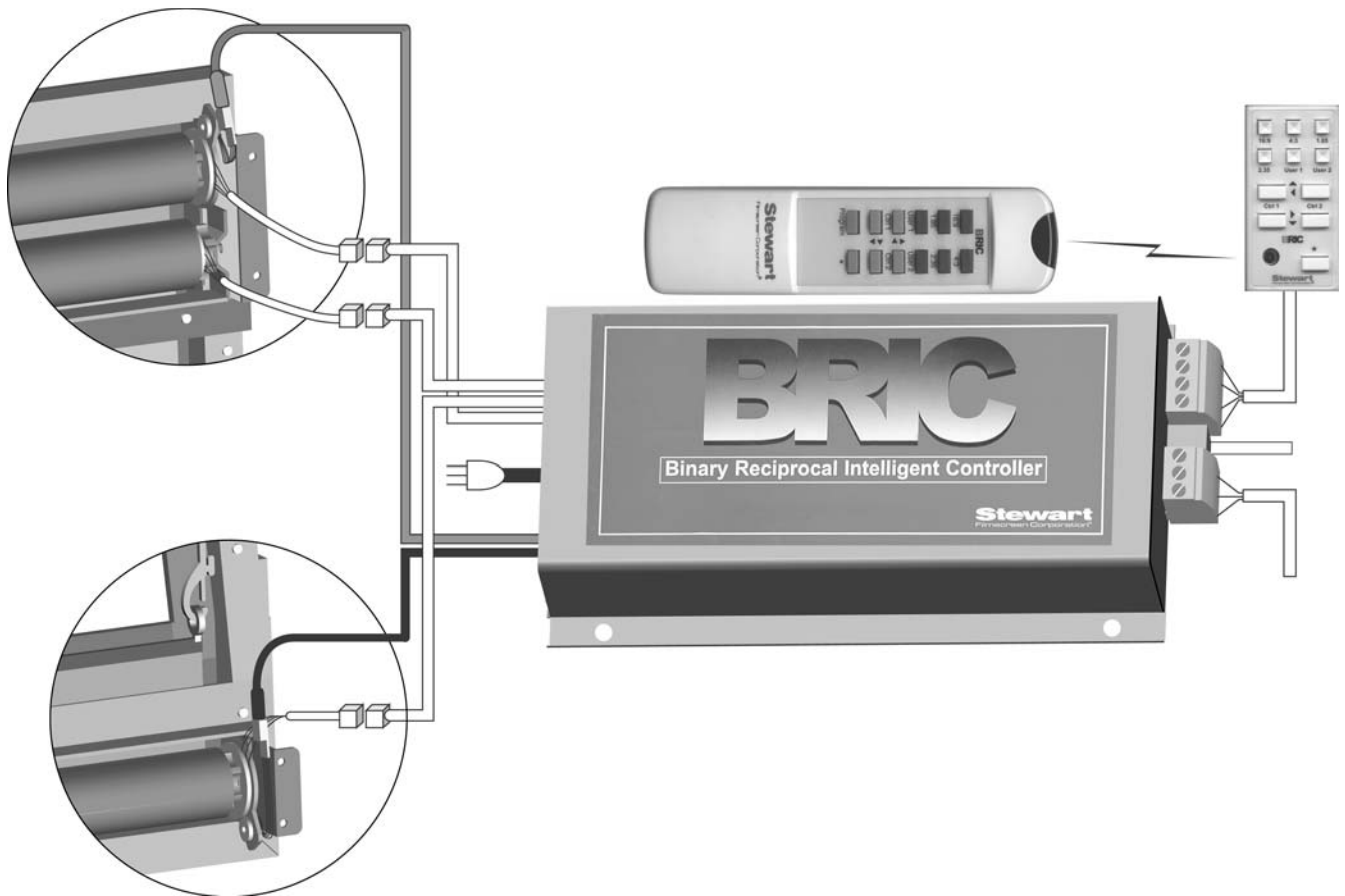

- TO THE OWNER
- INSTALLATION INSTRUCTIONS
 - OPERATION
- TECHNICAL NOTES

Printed in U.S.A.

©2004–2011 Stewart Filmscreen Corporation

Stewart Filmscreen reserves the right to make changes to the product specified in this document.

From time to time, this document is updated. Current versions of documentation are posted on the Stewart Filmscreen website at:

www.stewartfilmscreen.com

Contents

To the Owner	2
BRIC Component Overview	4
Installing a BRIC That Is Separate From the Screen	6
Installing a BRIC That Is Attached to the Screen	9
Attaching the Optional Infrared Sensor/RF Receiver	10
Connecting the BRIC to a Projector Using STI	11
Using the 11-button Keypad and Remote Control	12
Programming Preset Positions	15
Using Serial Communications	17
Troubleshooting	19
Technical Notes	24
Product Warranty	29

The BRIC (Binary Reciprocal Intelligent Controller) is a microprocessor-based controller device that is designed to control a wide variety of motorized Stewart Filmscreen screen systems. The two active (or intelligent) channels and one passive channel can be used to control the screen, a trapdoor, and/or horizontal and vertical masking devices, depending on the configuration of the screen.

The BRIC can be controlled in several ways:

- ◆ Manually, through a Stewart intelligent 11-button keypad
- ◆ Remotely, using a handheld remote control device or by third-party intelligent remote devices
- ◆ Via sophisticated Home Automation Systems (such as those manufactured by AMX, Crestron, and Elan Home Systems) through RS-232C or RS-485 interfaces
- ◆ Through an external low-voltage triggered switched output that is often provided with video projection devices and projectors

About this manual

Please take a moment to review this manual, it will help ensure you many years of trouble-free service from your new Stewart Filmscreen product. If installing a screen at the same time you are installing the BRIC, be sure to refer to the manual for the screen.

This manual is divided into several sections:

- ◆ Installing a BRIC that is mounted separately from the screen
- ◆ Installing a BRIC that is attached to the screen housing
- ◆ Adjusting screen and masking panel position using directional buttons
- ◆ Using and programming button presets
- ◆ A technical section to be used in circumstances with special requirements

Refer to the appropriate installation instructions, then refer to the sections on adjusting screen and masking panel position and for configuring presets.

Refer to the technical section if you have special requirements, such as:

- ◆ Need to interface with an external third-party controller
- ◆ Factory-directed troubleshooting

A note on BRIC configurations

A BRIC has two active (intelligent) channels and one passive channel. Each channel controls a different motor. Depending on the configuration of the screen, a channel may control a retractable screen, a horizontal or vertical masking panel, or a trapdoor.

There are two mounting options: separate and integrated. Integrated BRICs are pre-mounted on the screen housing. Separate BRICs are mounted apart from the housing, providing additional flexibility.

For some screen systems, the BRIC may be used in tandem with a second BRIC or a smaller BRIC with two passive channels.

General preparation for installation

Professional installation techniques should be used. Stewart Filmscreen Corporation cannot be liable for substandard or faulty installations.

Whether the BRIC is either pre-mounted on the screen unit, or is mounted separately from the screen, you will need:

- ◆ Appropriate AC power for your region. For example, in the U.S., use 125V AC 5 Amp power.

To complete the installation, you will need:

- ◆ General electrician tools
- ◆ Data communication tools

11-Button Keypad Handling Advisory

The 11-button keypad is shipped in anti-static bubble pack. The keypad's active circuit board is static sensitive and therefore care must be used when handling and installing the keypad. DO NOT touch the printed circuit board with hands, tools, or any other objects.

Avoid contact with sides of electrical box when installing the keypad.

DO NOT drop the keypad as the shock will cause it to fail.

- ◆ **Before proceeding with the installation of the BRIC, be sure to thoroughly read and understand all the installation and operating instructions.**
- ◆ **All electrical wiring installations must conform to local and national codes and should be performed by qualified service personnel.**
- ◆ **The BRIC is designed for indoor use.**
- ◆ **Earth terminal connection must be made.**
- ◆ **Do NOT connect low-voltage power to line voltage power.**

BRIC COMPONENT OVERVIEW

This section identifies the principal components of the BRIC. Note that your BRIC may have a somewhat different appearance. Refer to Figure 1.

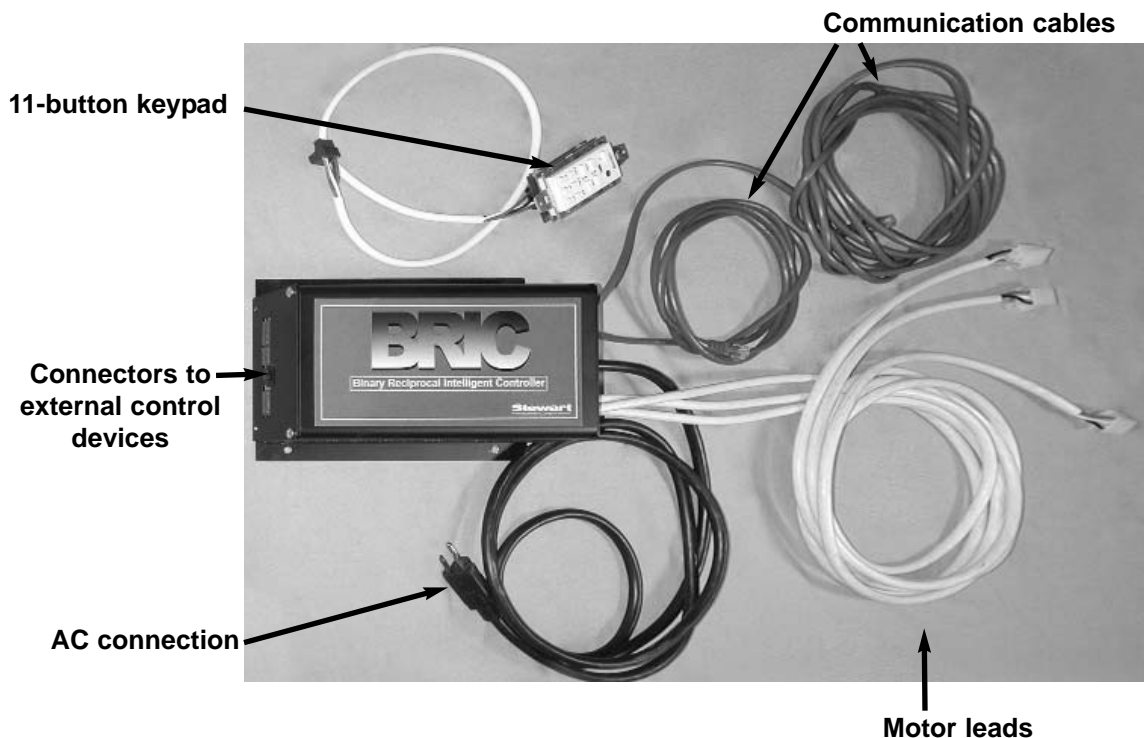

Figure 1. BRIC components

Each of the **communication cables** (sometimes referred to as encoder wires) may be the same color, or they may be different colors. They provide the intelligent communication between the motors and the BRIC.

The **11-button keypad** is one means of controlling the BRIC. A short length of cable is provided for you to test the function of the system before installing the keypad in its permanent location.

Motor leads on the BRIC have corresponding connectors on the screen or mask motors.

Several types of **connectors** are available for a variety of external control devices: 11-button keypad, STI, data communication port.

Caution

Do not cut or extend communication cables (encoder wires), as they are length-sensitive.

Do not substitute wires between the screen and the BRIC.

Test BRIC functionality during installation as instructed, before cosmetic finishing of the area is completed.

Do not install the BRIC in such a way that it is not accessible for maintenance.

Figure 2 provides an overview of BRIC components and connections.

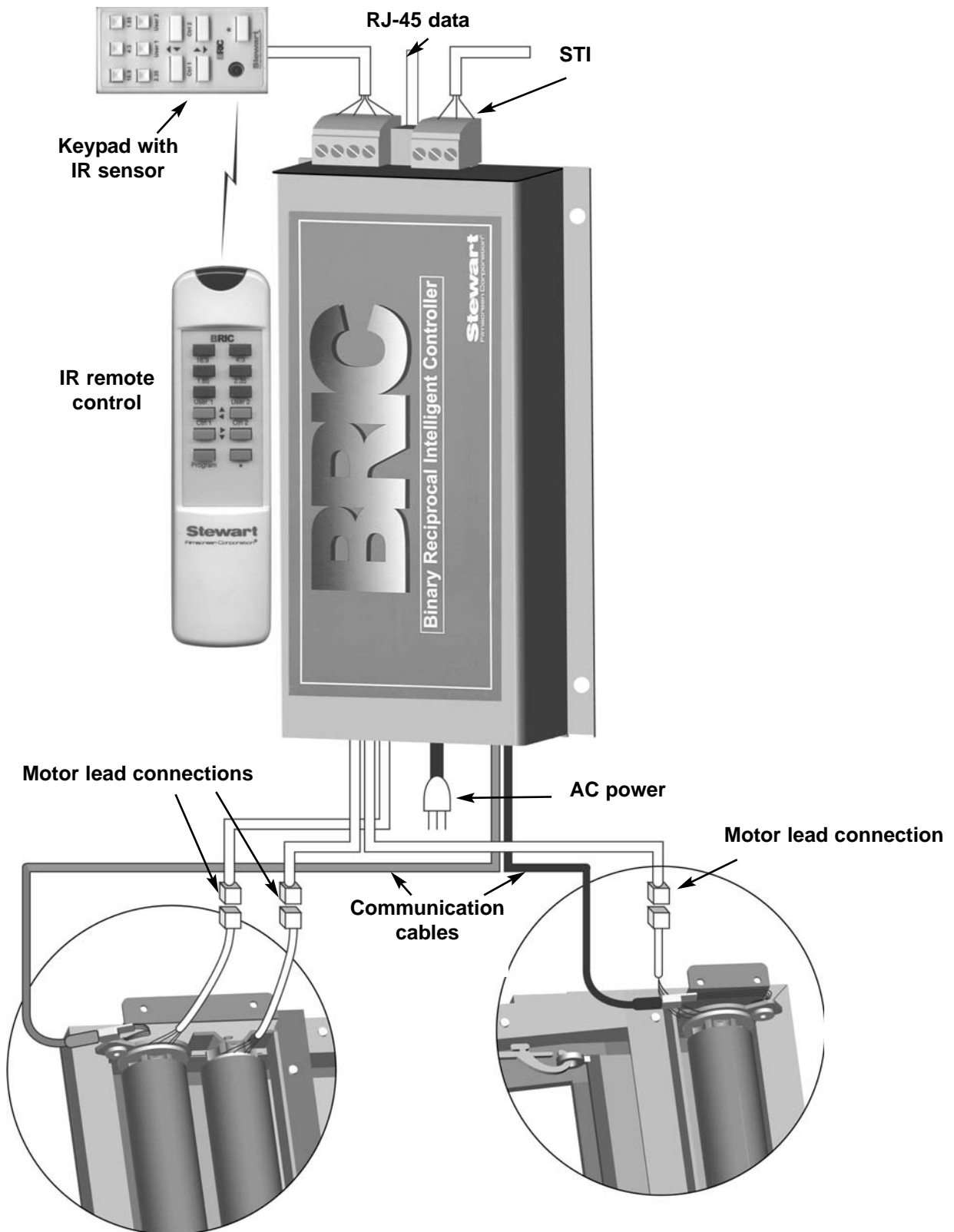

Figure 2. Component and connection overview

INSTALLING A BRIC THAT IS SEPARATE FROM THE SCREEN

This section describes the BRIC that is mounted separately from the screen.

Installation procedure

Note: During the installation procedure, you test the function of the system before installing the keypad in its permanent location. A short length of cable is provided for this purpose. Follow the steps in sequence.

1. Ensure that the AC power is available at the installation site.
2. Install the screen.
3. Mount the BRIC in the appropriate location.
4. Connect the BRIC to the screen motors. A nominal length of motor lead is provided. There is a motor lead for each motor. The connector on the BRIC side has a number that corresponds to a number on the appropriate connector on the motor. Refer to Figure 3.

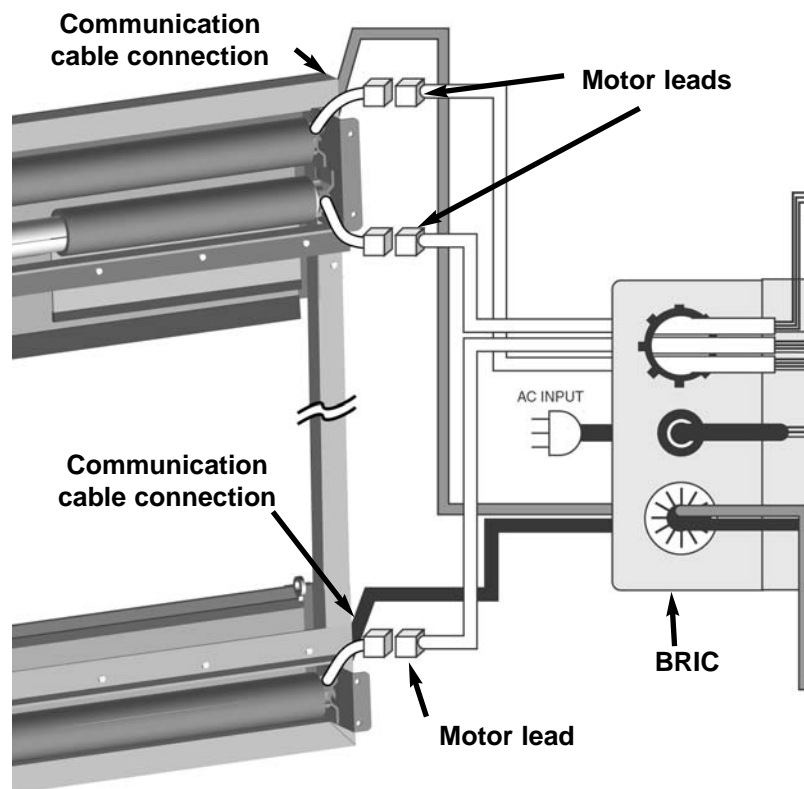

Figure 3. Connecting the BRIC

5. Connect the two communication cables from the BRIC to the motors.
 - ◆ Interconnects are labeled on both the motor and the BRIC. Be sure to match the interconnects correctly.
 - ◆ Standard telecommunications cable can be used for lengths of up to 3 meters (9.8 feet). For longer runs, amplifiers are used. Communications cables are length-sensitive. Do not cut or extend them.
 - ◆ If your BRIC uses amplifiers, ensure that the amplifier connections have not become loose.
6. Plug in the AC cord to the wall.
7. Use the short pigtail provided to temporarily connect the 11-button keypad to the BRIC for testing. Refer to Figure 4.

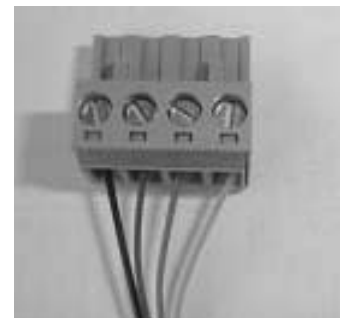
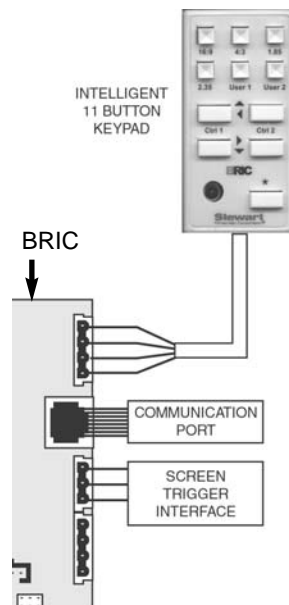

Figure 4. Connecting 11-button keypad to the BRIC

Figure 5. 11-button keypad connector

8. Test functionality by using keypad buttons to move the screen up and down. (Refer to the section “Using directional buttons to control screen or mask position” as needed.) When the system is functional, install the 11-button keypad in the appropriate location as follows.
9. Determine a suitable mounting location for the keypad that will be accessible to the user.

Note: Keep in mind that the keypad has an infrared sensor for communication with the remote control. If the keypad cannot be placed where there is convenient line of sight with the remote, an additional IR sensor or RF receiver are available as options on the BRIC.
10. Install a single-gang plastic or metal junction box to accommodate the BRIC keypad.

-
11. Connect CAT 5 (or CAT 3) or standard telephone communication wire between the selected keypad mounting location and the BRIC (24-gauge minimum wire, 500' / 152.4m maximum run).
 12. Connect wiring as shown in the below table. Specified wires should be connected to the appropriate connector on the keypad's back panel.

Connector	Keypad
Pin 1 (VCC+ 5volts)	Pin 1
Pin 2 (Data line A)	Pin 2
Pin 3 (Data line B)	Pin 3
Pin 4 (Ground)	Pin 4

Table 1. 11-button keypad wiring

13. Test the system again to verify operation.

Additional steps

If you have the optional extra infrared sensor or RF sensor, go to the section "Attaching the Optional Infrared Sensor/RF Receiver" starting on page 10.

If the system will be connected to a projector with the STI connector, go to the section "Connecting the BRIC to a Projector Using a Screen Trigger Interface" on page 11.

Check each of the preset buttons using the keypad or remote to ensure that the preset positions are appropriate for the screen and projector. Adjust the programming as needed. Refer to the section "Using the 11-button Keypad and Remote Control" starting on page 12.

If the system will be connected to a PC or Home Automation System, go to the section starting on page 17.

INSTALLING A BRIC ATTACHED TO THE SCREEN

This section describes the BRIC that is attached to the screen housing. Refer to Figure 6 for a guide to BRIC components.



Figure 6. BRIC components

Installation procedure

Note: During the installation procedure, you test the function of the system before installing the keypad in its permanent location. A short length of cable is provided for this purpose. Follow the steps in sequence.

1. Ensure that the AC power is available at the installation site.
2. Install the screen.
3. Plug in the AC cord to the wall.
4. Use the short pigtail provide to temporarily connect the 11-button keypad for testing.
5. Test functionality by using keypad buttons to move the screen up and down. (Refer to the section on “Using directional buttons to control screen or mask position” as needed.) When the screen is functional, install the 11-button keypad in the appropriate location as follows.
6. Determine a suitable mounting location for the keypad that will be accessible to the user.
Note: Keep in mind that the keypad has an infrared sensor for communication with the remote control. If the keypad cannot be placed where there is convenient line of sight with the remote, an additional IR sensor or RF receiver are available as options on the BRIC.
7. Install a single-gang plastic or metal junction box to accommodate the BRIC keypad.

Connector	Keypad
Pin 1 (VCC+ 5volts)	Pin 1
Pin 2 (Data line A)	Pin 2
Pin 3 (Data line B)	Pin 3
Pin 4 (Ground)	Pin 4

Table 2. 11-button keypad wiring

8. Connect CAT 5 (or CAT 3) or standard telephone communication wire between the selected keypad mounting location and the BRIC (24-gauge minimum wire, 500'/ 152.4m maximum run).
9. Connect wiring as shown. Specified wires should be connected to the appropriate connector on the keypad's back panel.

Additional steps

If you have the optional extra infrared sensor, go to the section "Attaching the Optional Infrared Sensor/RF Receiver" starting on page 10.

If the system will be connected to a projector with the STI connector, go to the section "Connecting the BRIC to a Projector Using a Screen Trigger Interface" on page 11.

Check each of the preset buttons on the keypad or remote to ensure that the preset positions are appropriate for the site. Adjust the programming as needed. Refer to the section "Using the 11-button Keypad and Remote Control" starting on page 12.

If the system will be connected to a PC or Home Automation System, go to the section starting on page 17.

ATTACHING THE OPTIONAL INFRARED SENSOR/RF RECEIVER

The remote control operates by infrared communication with a sensor in the 11-button keypad. It requires unimpeded line-of-sight to the sensor to function. If the keypad is not placed in a location convenient for using the remote control, an additional infrared sensor can be installed as an option.

In addition to the infrared sensor, an optional RF (radio frequency) receiver is available. Connect the infrared sensor or the RF receiver using the RJ-11 connector on the BRIC.

RJ-11 connector for infrared connector or RF receiver



Figure 7. BRIC circuit board

CONNECTING THE BRIC TO A PROJECTOR USING SCREEN TRIGGER INTERFACE

If your projector is equipped with a DC-triggered output that is activated when the video projector is turned on, you can connect this output to the BRIC directly. This enables the BRIC to automatically raise and lower the screen when you turn the projector on or off.

Note: Most AV systems emit a nominal 12 V signal.

The STI connection is located near the keypad connection on the BRIC. Refer to Figure 9. Use a 3-pin connector as shown in Figure 8, as well as two-conductor twisted pair or non-twisted pair (minimum 24 gauge) from the video projector's trigger output to the BRIC connectors.

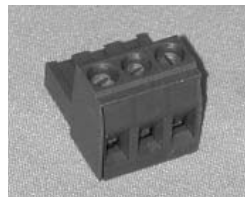

Figure 8. STI connector

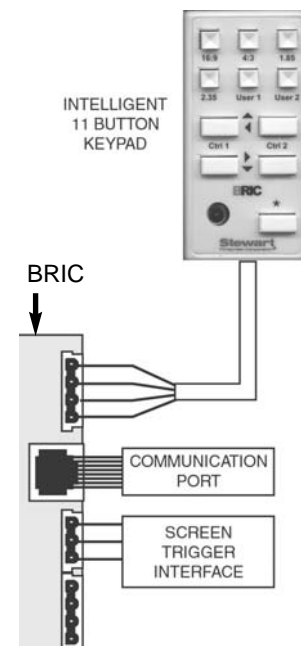

Figure 9. Connecting 11-button keypad to the BRIC

Note: The BRIC has the option of providing a second DC-triggered input (such as might be provided on a projector that has a basic trigger for power-on and a secondary trigger for a 16:9 video source). This feature enables the BRIC to set the screen and its associated masking screens to Preset 1 upon receiving a trigger from the projector that the projector has been turned on, and then enabling the BRIC to set the screen and associated masking screen to Preset 2 upon receiving a trigger that the projector is projecting a 16:9 video source.

Important Wiring Considerations

- ◆ To be compatible, the DC trigger output must be isolated and have a minimum rated output of at least 5 ma @ 5 volts (10ma @ 12 volts).
- ◆ BRIC will accept inputs of up to 30 volts DC. Do NOT exceed this input voltage.

USING THE 11-BUTTON KEYPAD AND REMOTE CONTROL

This section describes the 11-button keypad and 12-button IR remote control. The keypad and remote control have nearly identical buttons. The remote control has one additional button dedicated to programming the presets. There are two keypad versions, version 1 and version 2. Version 2 was provided starting in 2010. It has a RJ-25 connection port.

Note: Preset positions are usually programmed at the factory. Screen or masking panel positions may need to be adjusted. If preset buttons do not function, use directional buttons to position the screen or masking panel(s) and program the preset buttons.

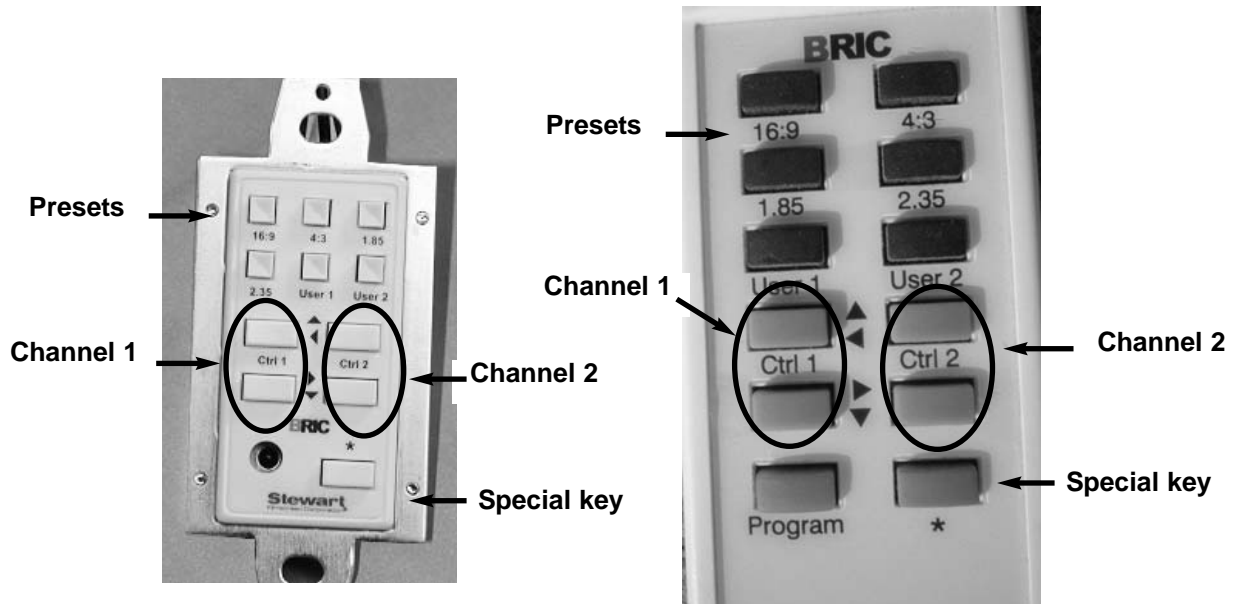

Figure 10. 11-button keypad, version 1

Figure 11. 12-button IR remote

Preset buttons (4:3, 16:9, 1.85, 2.35, User 1 and User 2)

The preset buttons, when programmed, enable the BRIC to automatically set the precise position of the screen and any horizontal or vertical masking panels available.

Note: If these buttons do not function, use the directional buttons to position the screen or masking panel, and then use the procedure for programming the preset positions, starting on page 15.

When you want to set the screen system to a programmed position, for example 16:9, press the appropriate preset button. The BRIC will fully extend the screen and then move to the programmed position.

Channels 1 and 2: Directional buttons

The Ctrl 1 and Ctrl 2 directional buttons enable a retractable screen or mask to be lowered or retracted to the desired position. The top button of each pair moves the screen or mask up or to the left, while the bottom button of each pair moves the screen or mask down or to the right.

Note: Most screens have an up/down motion. Some models have panels with a left/right motion.

Special key (*)

This key controls the passive channel. For example:

- ◆ For screens that have a vertical mask, this button can move the mask from its current position to its opposite position. No interim positioning is possible, as with the Ctrl 1 and 2 directional buttons.
- ◆ For screens with a trap door, this button can be a "Home" button that retracts any screens or mask panels that are extended to their fully closed or HOME position and then closes the door.

Channel definition for your system

On your system, the channels control the motors for the elements identified below.

- ◆ Channel 1 <Ctrl 1> key: _____
(e.g., screen, vertical mask, horizontal mask top/bottom)
- ◆ Channel 2 <Ctrl 2> key: _____
(e.g., screen, vertical mask, horizontal mask top/bottom)
- ◆ <*> key: _____
(e.g., screen, vertical mask, trapdoor)

Installer note

Complete this section
for the owner's
reference.

11-button keypad illumination

This keypad has a backlit blue LED function that is useful for seeing the keypad in a darkened room. You can enable or disable the backlit illumination.

To **enable** the backlit illumination:

1. Press and hold down the * button.
2. Press the Ctrl 1 Up button while still pressing the * button.
3. Release the * button.
4. Release the Ctrl 1 Up button.

To **disable** the backlit illumination:

1. Press and hold down the * button.
2. Press the Ctrl 1 Down button while still pressing the * button.
3. Release the * button.
4. Release the Ctrl 1 Down button.

Using directional buttons to control screen or mask position

Projection screens work best if they are fully extended at the beginning of each viewing session prior to being adjusted. For this reason, the BRIC fully extends the screen element initially before moving to any pre-selected position. Do not interrupt the movement, while the screen is in the process of reaching its initialization position.

In general, use the preset buttons to position the screen or masking panels appropriately. If an adjustment is needed, use the directional buttons for more precise positioning.

To move the screen or mask

Momentarily depress the Down or Up button for the channel that controls the screen or mask you wish to adjust. Once the button is released, the screen or mask will move in the desired direction.

Note: If the screen or mask is in motion, and you depress the opposite directional button for the screen or mask, the BRIC prevents damage to the active motor by pausing the operation in progress and then proceeding with the newly selected operation.

To stop the motion of the screen or mask

Once the screen has reached the desired position, momentarily depress the **same** directional button previously depressed (while the screen is actually moving in the direction indicated by that button). Once the button is released, then the specific motor running will immediately stop.

Opening and closing the trapdoor

This section applies to screens with a trapdoor. For systems that have a trapdoor, the special key (*) is generally used to operate the trapdoor.

The trapdoor automatically closes when:

- ◆ The * button on the keypad or remote control is pressed.
- ◆ All screens (and any masking panels) have been fully retracted into the screen chassis.

PROGRAMMING PRESET POSITIONS

The BRIC stores preset positions in its memory. The positions are retained even in case of the power outage.

- ◆ Six presets are available when using the keypad or the remote control.
- ◆ Nine presets are available when using a PC or Home Automation System.

The standard preset positions are programmed at the factory. You may need to make adjustments once the system is installed.

The keypad and the remote control have buttons you can use to invoke preset positions. There are two user-defined buttons for custom settings. Using serial commands for a PC or Home Automation system is described in the next section and the “Technical Notes” section of this manual.

Before programming a preset, establish the correct position for screen and/or masking panels for a given preset. Use the directional buttons to adjust the screen or masking panels as needed. Refer to section “Using directional buttons to control screen or mask position.”

Once the screen and panels are in the correct position, you can program the preset using the remote control or the 11-button keypad. In general, using the remote control is easier, as it has a Program button. It is also possible to perform the programming from a PC or home automation system using the serial connection. Regardless of the method used to configure a preset, the programming is retained in memory on the BRIC. If you use the remote control to program the preset, then the corresponding preset button on the keypad will function in the same way.

Once you have programmed the screen/masking environment for a particular preset, the setting remains until you overwrite that position through subsequent programming.

Note: Preset buttons are labeled on the keypad and remote control for convenience. You can configure any combination of screen/masking settings for any preset button. If you make changes, you may wish to place a new label over the existing label.

Programming preset positions using the remote control

1. Position the screen and/or masking panels to the appropriate settings for the button. Use directional buttons as needed to make adjustments.
2. Depress momentarily the PROGRAM button on the bottom right-hand corner of the 12-button infrared remote.
3. Depress momentarily the specific preset button (e.g., 4:3, 16:9, 1.85, 2.35, User 1, User 2) to store the current screen position. If you do not press the preset button within five seconds, the BRIC exits the programming mode.

Programming preset positions using the 11-button keypad, version 1

1. Position the screen and/or masking panels to the appropriate settings for the button. Use directional buttons as needed to make adjustments.
2. Press and hold down the * button.
3. While still pressing the * button, press and hold the specific preset button (e.g., 4:3, 16:9, 1.85, 2.35, User 1, User 2) to store the current screen position.
4. Release the * button.
5. Release the preset button.

Note: You must follow the steps in the sequence specified for the memory function to be invoked.

Programming preset positions using the 11-button keypad, version 2

1. Position the screen and/or masking panels to the appropriate settings for the button. Use directional buttons as needed to make adjustments.
2. To save presets press and hold the key for 5 seconds; you will hear a "beep" when the preset is stored.

USING SERIAL COMMUNICATIONS FOR PCs AND EXTERNAL HOME AUTOMATION SYSTEMS

The BRIC is designed to work with PCs and third-party Home Automation Systems using serial (RS-232C or RS-485) communication. This enables the BRIC system to automatically respond to external serial control commands.

This communication feature is particularly valuable when the BRIC is integrated with Home Automation Systems employing touchscreen LCD panels and other advanced user interfaces.

Connecting to PCs and External Home Automation Systems

In order to utilize the serial communication features of your BRIC you need:

- ◆ Windows PC or Home Automation System with DB-9 (serial) connector
- ◆ Stewart-provided connector and RS-232C cable OR
- ◆ Custom-made RS-232C cable with DB-9 to RJ-45 terminations as specified within the “Technical Notes” section of this manual.

A Stewart-provided connector is available to connect the serial interface of the PC and the RJ-45 interface on the BRIC.



Figure 12. Serial (RS-232C/DB-9) to RJ-45 connector

If you plan to create your own interface cable to connect between the BRIC system and your intended serial controller, refer to:

- ◆ Documentation provided with the special serial interface connection to which you wish connect the BRIC.
- ◆ “Technical Notes” section of this manual.

The 11-button keypad can be used for additional control of the BRIC system.

Features

All features that are available using the 11-button keypad or the 12-button IR remote control are also available using remote serial communication features of the BRIC. Additional commands are available only through serial communications: Presets #7—9 and monitor diagnostics. Refer to the “Technical Notes” section for more information.

Controlling the BRIC from a remote PC

Sample code for control code programming is available in the “Technical Notes” section.

1. If the cable is not already connected between the PC and the BRIC, do the following:
 - ◆ Turn off the computer that you plan to connect to the BRIC.
 - ◆ Connect the cable between the computer and the BRIC RJ-45 connector.
2. Power on the computer system.
3. Launch Microsoft Windows HyperTerminal or similar communication program.
4. In the Connection Description menu, type **BRIC Gold**, select an icon and click OK.
5. In the Connect To menu, select Direct to Comm 1 or Comm 2 as appropriate and click OK.
6. In the Comm 1 or 2 Properties menu, select 19200 Bits per second, 8 Data Bits, None Parity, 1 Stop Bit, None Flow Control and click OK.
7. In the BRIC Gold Hyper Terminal window, enter the command that you would like to send to the BRIC system in upper case letters, click Transfer, and select Send Text File. Commands will transfer to BRIC.

If convenient, you can leave the cable connected to enable future command transfers between the PC and the BRIC.

Once you have configured and stored a particular preset on the BRIC (regardless of whether these settings were made through the keypad, remote, or through serial communications), you can recall these presets by invoking the particular Preset command on any user interface. This enables you to control the BRIC from remote computer/Home Automation Systems easily and quickly.

General operation problems

If the screen or masking panel moves slightly then stops during activation, there may be a problem with communication cables.

If a preset does not hold its setting, even though the screen or mask operates correctly with the directional buttons, there may be a problem with the communication cables.

For suspected communication cable problems, check the cables for loose connections, broken wire, or wire that is too long for use without an amplifier.

11-button keypad problems

Problem description	Probable cause	Action to take
Keypad does not work at all.	Power to screen is off.	Switch power on to BRIC.
	Connections between keypad and BRIC system have not been made.	Make proper connections to keypad. Note: Keypad pin #1 is 5v, pins #2-3 are signal, and pin #4 is ground. (Refer to page 10.) Serious damage to the keypad may result if you reverse pins #1 and #4.
	Fuse inside BRIC may be blown.	Check other troubleshooting steps before contacting Stewart Filmscreen regarding fuse repair.
Keypad function is sporadic.	Length of wire between BRIC and keypad may exceed recommended length.	Use CAT3 or CAT5 with lengths less than 100 feet between BRIC and keypad.
	Twisted pair grouping of 4 wires running from keypad to BRIC may be inconsistent.	Follow directions on color coding of CAT3 or CAT5 wire from keypad to BRIC. Refer to page 10.
Backlit LEDs do not illuminate, but UP/DOWN buttons do work.	The proper sequence of button pushes to turn LEDs ON has not been followed.	Refer to page 13.
Backlit LEDs are illuminated but cannot be turned OFF at the keypad.	The proper sequence of button pushes to turn LEDs OFF has not been followed.	Refer to page 13.
Backlit LEDs are illuminated but only some of the various keypad buttons function.	Incorrect wiring to the keypad.	Check wiring to Pins #2 and #3 at keypad.
Backlit LEDs are illuminated but none of the various keypad buttons function	Incorrect wiring to the keypad.	Check wiring to Pins #2 and #3 at keypad—they may be backwards.
Pressing a button on the keypad causes a motor to advance only 1" (2.5 cm) before turning off.	Digital encoder(s) may not be properly connected to the BRIC. This symptom is a warning that the encoders should be connected properly.	Connect wiring harness from the digital encoders to the appropriate connection points on the BRIC. If there are two encoders, make sure that both encoders are properly connected.

Problems with trapdoor

Problem description	Probable cause	Action to take
Door does not move when all screens are fully retracted.	Power to Stewart screen is OFF.	Switch on power to BRIC.
	Internal DIP switch in BRIC is not set correctly.	Set DIP switch to positions specified for the appropriate configuration as specified in the Technical Notes section of this manual.
	Fuse inside BRIC may be blown.	Check other troubleshooting steps before contacting Stewart Filmscreen regarding fuse repair.
Door does not move, and BRIC on-board LED flashes a sequence of 1 flash then OFF, and repeats.	Connections between Door Open Microswitch on screen chassis and BRIC are faulty.	Check correct wiring or operation of Door Open Microswitch (internal switch that activates when door is fully open).
Door does not move, and BRIC on-board LED flashes a sequence of 2 flashes, then OFF, and repeats.	Connections between Door Closed Microswitch on screen chassis and BRIC are faulty.	Check correct wiring or operation of Door Closed Microswitch (internal switch that activates when door fully closes).
Door does not move, and BRIC on-board LED flashes a sequence of 3 flashes, then OFF, and repeats.	Connections between Door Closed Microswitch (internal switch that activates when door fully closes) are faulty.	Check wiring connections to both microswitches.
Door may open but does not close. No error flashes on BRIC on-board LEDs.	Connections between door proximity or batten sensors on bottom of screen (and/or mask batten) and BRIC unit are loose or disconnected.	Correct wiring to all batten detectors (screen and mask if provided) and BRIC unit.
When Ctrl 2 DOWN button is pressed, DOWN motor for the other motor moves DOWN instead.	Incorrect wiring.	Check wiring to pin #3 at keypad.
When Ctrl 2 UP button is pressed, UP motor for the other motor moves DOWN instead.	Incorrect wiring.	Check wiring to pin #3 at keypad.

Screen Trigger Interface problems

Problem description	Probable cause	Action to take
Screen does not move when single trigger STI connection to video projector is made.	Power to screen is OFF.	Switch on power to BRIC.
	Fuse inside BRIC may be blown.	Check other troubleshooting steps before contacting Stewart Filmscreen regarding fuse repair.
	Power to projector is OFF.	Switch on power to BRIC.
	Wiring to video and BRIC #1 STI connector is loose or improper.	Check wiring. Polarity to BRIC STI connector is (+) on pin 1 and (-) on pin 2.
	Preset 1 was not programmed into BRIC unit before STI was activated.	Program a positional location for Preset 1 prior to using the STI option.
Screen does not move to either Preset 1 or Preset 2 when both (2) STIs are connected (to a BRIC unit).	See all of the steps under the above topic.	See above.
	Wiring to video and BRIC double channel STI connector are loose or improper.	<p>Check to make sure that the first channel STI that is activated when the projector first turns on is correctly connected to Pins #1 and #2 of the BRIC. A second channel STI (available on some projectors) may activate in special cases when a 16:9 widescreen signal is being projected. In such cases, this second channel STI MUST be connected to the BRIC's second channel STI (Pins #3 and #2 of the STI connector).</p> <p>1st STI connects to Pin 1 (+), and Pin 2 (-) and activates Preset 2 (4:3 or other aspect ratio mapped into Preset 2).</p> <p>2nd STI connects to Pin3 (+) and Pin (common) and activates Preset 1 (16:9 or other aspect ratio mapped into Preset 1).</p> <p>Note: It is required that a signal always be active on the First Channel STI in order for the Second Channel STI to operate. If your projector is a native 16:9 projector you may have a secondary STI interface for alternative aspect ratios. In such case, YOU SHOULD program the BRIC's first PRESET to coincide with the aspect ratio associated with the first channel STI output and then program the second PRESET to coincide with the aspect ratio associated with the second channel STI output.</p>

Screen Trigger Interface problems, cont.

Problem description	Probable cause	Action to take
Projector has a single STI which activates when a 16:9 (typically Preset 1) image (rather than a 4:3 image—Preset 2) is projected. BRIC, upon seeing the first STI, activates Preset 2 (4:3 aspect ratio) which apparently is the wrong aspect ratio.	The BRIC is designed to trigger Preset 2 upon seeing the first STI.	Tie pins #1 and #3 of J7 together and connect the combination pin to the projector's first 12v +STI output. Connect pin #2 of J7 to the projector's first STI 12v- output.
Screen moves to Preset 1 position but does not move to Preset 2 position when 2 STIs are connected.	Wiring between video projector's STI output and BRIC's second channel STI connection (Pins#3 and #2) are loose, broken or improper.	Check wiring. Polarity to BRIC's STI connectors. 1 st STI connects to Pin 1 (+), and Pin 2(-). 2 nd STI connects to Pin3 (+) and Pin (common).
	Preset 2 was not programmed into BRIC unit before STI was activated.	Program a positional location for Preset 2 prior to using the STI option.

Infrared remote control problems

Problem description	Probable cause	Action to take
System does not respond when using IR remote control.	Power to screen is off.	Switch power on.
	Fuse inside BRIC may be blown.	Check other troubleshooting steps before contacting Stewart Filmscreen regarding fuse repair.
	Connections between keypad/or remote IR sensor and BRIC system have not been made.	Make proper connections. Check details within this document.
	Direct sunlight may be shining on IR sensor (on keypad or optional additional IR sensor).	Take precaution to install keypad out of direct sunlight. If problem persists, cover keypad IR window and install optional IR sensor in a location away from direct sunlight.

Remote serial connection problems

Problem description	Probable cause	Action to take
Remote Serial Connection to Home Automation product appears not to be working.	Power to screen is off.	Switch power on.
	Fuse inside BRIC may be blown.	Check other troubleshooting steps before contacting Stewart Filmscreen regarding fuse repair.
	Incorrect wiring.	Check wiring diagram as specified within this document.
	Connections between keypad and BRIC system have not been made.	Make proper connections. Note: Serial communication is bi-directional. The transmitting unit will generate -5V to -12VDC on the transmitting line. If you suspect that one of the three serial lines may be broken or improperly connected, determine which receiving device is not receiving specified DC power on the applicable wire.
Length of wire between BRIC and keypad may exceed recommended length.	Use CAT3 or CAT5 with lengths less than 50 feet between BRIC and auxiliary serial device. Note: the specification for RS-232C permits reliable communication at specified transmission speeds within distances up to 50' (15.2 m) from transmitting device. If you plan on communication with the BRIC device using serial communication over distances with exceed the RS-232C specification, consider utilizing the alternative RS-422 communication standard provided as standard with the BRIC unit. Consult the wiring diagram within this document for more information.	
Remote Serial Connection seems not to be working reliably.	Partially incorrect wiring to BRIC.	Serial communication to the BRIC is bi-directional. Occasionally the BRIC's transmit and transmit ground pins may be wired correctly to a remote computer but the BRIC receive and receive ground pins may be reversed. In this case, the BRIC will seemingly work but its behavior may be problematic or non-predictable. Note the proper wiring for the serial cable to the BRIC and verify the correct wiring, particularly for the receive and receive ground pins.

This section provides more technical information for special circumstances.

BRIC internal layout and connectivity

In most cases, you do not need to open the BRIC housing when you install the BRIC. Whether you have the separate or the integrated BRIC, the layout of the circuit board is the same. The separate BRIC is likely to incorporate an amplifier. The integrated BRIC communication cables may be bundled with the motor leads.

To gain access to the circuit board, you must open the housing. To do this, slide the top of the housing back.

Figure 13 shows the layout of the main components of the internal circuit board and shows the connectors to the screen motors and to the control devices (e.g., keypad, etc.).



Figure 13. Internal layout of the BRIC circuit board

Creating a custom serial cable / RJ-45 pin-out

There are several types of serial connections on third-party computer devices. Stewart provides a Serial-to-RJ-45 connector. However, if you need to create your own interface cable to connect between the BRIC and your intended serial controller, refer to this section and the documentation that was provided with the PC regarding the serial interface connection to which you wish connect the BRIC.

For typical DB-9 PC connections, you can make an interface cable as described in this section.

Use a Cat 5 cable, with an RJ-45 connector on one end (for connection to the BRIC), and a DB-9 (serial) connector on the other end (for connection to the PC).

Note: A DB-9 connector is the type typically used for RS-232 (serial) connections.

The figure below lists how each of the wires needs to be fastened to each of the connectors.

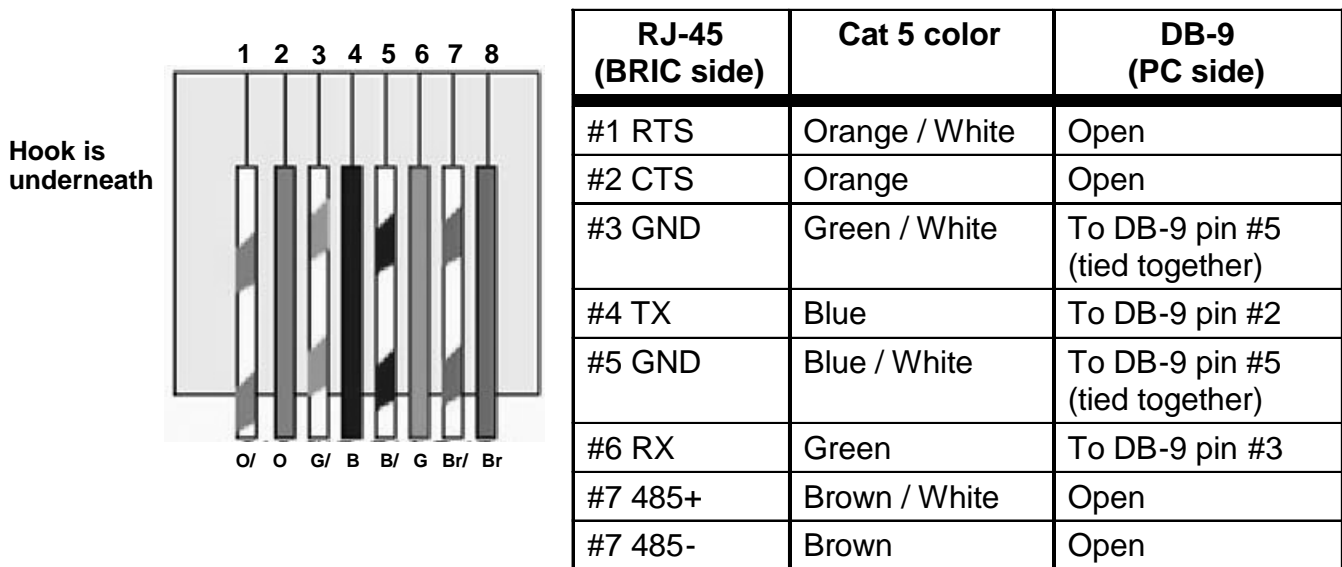

Figure 14. RJ-45 pin-out

The Identity Module

The BRIC circuit board has an element referred to as an “identity module.” This component determines how the BRIC controls the motorized elements on the various types of Stewart filmscreen models. The identity module may be red or blue, depending on when it was manufactured. There are different modules for smaller BRIC models (e.g., Bronze).

In general, the settings are configured at the factory and are not changed. The correct settings are listed in Table 3.

The “Description” column identifies the type of screen (some screens use two BRICs). The illustrations to the left show the proper pin settings for that type of screen. The “Tension cycle” column indicates whether the BRIC fully extends the element before returning it to its specified position.

The Motor C column identifies the element controlled by the passive channel, if any. The last column describes the behavior of the Special (*) key on the 11-button keypad or remote control.

BRIC



The table indicates the motor direction (as seen from the end—viewing the cable entry—along the shaft) when the screen or mask UP button is depressed. Direction is shown by a clockwise arrow or a counter-clockwise arrow. In the switches section of the table, a dot signifies ON.

	Switches								Description	Motor A		Motor B		Motor C		Tension cycle	Remote / Keypad * button	
	1	2	3	4	5	6	7	8		Direction	Initialize	Direction	Initialize	Direction	Initialize			
0									Test Mode									
02								●	02	BEMVV	↻	UP↻	↻	UP↻	↻	UP↻	No	Toggle Channel C
03								●●	03	ATBEMHV Master	↻	UP↻	↻	UP↻	Door		Yes	Retract / Home
04								●	04	EMHV	↻	UP↻	↻	UP↻	↻	UP↻	Yes	Toggle Channel C
05								●●	05	EMH2V - Master	↻	UP↻	↻	DOWN↻			No	Retract / Home
06								●●	06	EMH2V - Slave	↻	LEFT↻	↻	RIGHT↻			No	Retract / Home
07								●●●	07	EMH, EMHC	↻	UP↻	↻	UP↻			Yes	Retract / Home
08								●	08	EMSNH CC, VTC	↻	UP↻	↻	DOWN↻			No	Stop
09								●●	09	Dual Masking EMHV	↻	UP↻	↻	UP↻	↻	UP↻	Yes	Toggle Channel C
10								●●	0A	4WSN	↻	UP↻	↻	DOWN↻	↻	UP↻	No	Toggle Channel C
11								●●●	0B	8 Way Slave	↻	LEFT↻	↻	RIGHT↻			No	Stop
12								●●	0C	8 Way Master	↻	UP↻	↻	DOWN↻			No	Toggle M/S
13								●●●	0D	Directors Master	↻	UP↻	↻	DOWN↻			No	Toggle M/S
14								●●●	0E	Directors Slave	↻	LEFT↻	↻	RIGHT↻			No	Stop
15								●●●●	0F	ABTEMH	↻	UP↻	↻	UP↻	Door		Yes	Retract / Home
16								●	10	EMSNJ	↻	UP↻	↻	DOWN↻			No	Stop
17								●	11	4WSNJ	↻	UP↻	↻	DOWN↻	↻	UP↻	No	Toggle Channel C

Table 3. BRIC Identity Module settings

1	2	
		120 sec
	●	90 Sec
●		60 Sec
●	●	30 Sec

Timeout switch settings

BRIC Bronze

The table indicates the motor direction (as seen from the end—viewing the cable entry—along the shaft) when the screen or mask UP button is depressed. Direction is shown by a clockwise arrow or a counter-clockwise arrow. In the table, a dot signifies ON. Dip switches 1 and 2 are used to set dwell time or motor relay timeout.

	Switches								Description	Motor A		Motor B		Remote / Keypad * button	
	1	2	3	4	5	6	7	8		Direction	Initialize	Direction	Initialize		
0									Test Mode						
2								●	02		↻	UP↻	NA	NA	HOME
3								●●	03		↻	UP↻	NA	NA	STOP
4								●	04		↻	UP↻	DOOR		Retract / Home
5								●●	05		↻	UP↻	↻	UP↻	HOME
6								●●	06		↻	UP↻	↻	UP↻	STOP
7								●●	07	4 Way	↻	UP↻	↻	DOWN↻	NA

Table 4. BRIC Bronze Identity Module settings

Serial commands

When controlling the BRIC from a remote PC, you enter commands to specify the settings. This section documents commands available at the time of publication.

When creating the connection, be sure to select or enter the following:

- ◆ Bits per second: 19200
- ◆ Data Bits: 8
- ◆ Parity: None
- ◆ Stop Bit: 1
- ◆ Flow Control (handshaking): None
- ◆ Data type: Parameters

Some commands are common to all Stewart screen systems, and some vary, based on the configuration (e.g., whether there is a vertical or horizontal masking system).

Commands common to all screen systems

The table below identifies commands common to all screen systems. Note that there are more presets available with serial communications than with the 11-button keypad or remote control.



Keep in mind that the character following the alphanumeric command represents a carriage return with no line feed.

Commands are case sensitive.

Key

- ◆ 1st two characters (01)= Device ID
- ◆ The default address is 01.
- ◆ 3rd character= Function (M-Move, P-Program, D-Down)
- ◆ 4th character= Preset location or motor (motor identified A, B, C, or D)

Function	Command
Home	01M0↵
Preset 1 (16:9)	01M1↵
Preset 2 (4:3)	01M2↵
Preset 3 (1.85)	01M3↵
Preset 4 (2.35)	01M4↵
Preset 5 (user 1)	01M5↵
Preset 6 (user 2)	01M6↵
Preset 7 (user 3)	01M7↵
Preset 8 (user 4)	01M8↵
Preset 9 (user 5)	01M9↵
Program preset 1	01P1↵
Program preset 2	01P2↵
Program preset 3	01P3↵
Program preset 4	01P4↵
Program preset 5	01P5↵
Program preset 6	01P6↵
Program preset 7	01P7↵
Program preset 8	01P8↵
Program preset 9	01P9↵

Table 5. Common serial commands

Screen-specific commands

The tables below identify commands specific to screen systems.

ABT with Horizontal Mask	
Function	Command
Screen Up	01UA↵
Screen Down	01DA↵
Horizontal Mask Up	01UB↵
Horizontal Mask Down	01DB↵
Door Close/Open	01DC↵

ABT with Vertical Mask	
Function	Command
Screen Up	01UA↵
Screen Down	01DA↵
Vertical Mask Up	01UB↵
Vertical Mask Down	01DB↵
Door Close/Open	01DC↵

ElectriScreen with Horizontal Mask	
Function	Command
Screen Up	01UA↵
Screen Down	01DA↵
Horizontal Mask Up	01UB↵
Horizontal Mask Down	01DB↵

ElectriScreen with Vertical Mask	
Function	Command
Screen Up	01UA↵
Screen Down	01DA↵
Vertical Mask Up	01UB↵
Vertical Mask Down	01DB↵

Four-way Screen	
Function	Command
Top mask Up	01UA↵
Top mask Down	01DA↵
Bottom mask Up	01UB↵
Bottom mask Down	01DB↵
Side mask Up	01UC↵
Side mask Down	01DC↵

Ultimate Four-way Screen	
Function	Command
Top mask Up	01UA↵
Top mask Down	01DA↵
Bottom mask Up	01UB↵
Bottom mask Down	01DB↵
Left mask in	01DC↵
Left mask out	01UC↵
Right mask in	01UD↵
Right mask out	01DD↵

Table 6. Screen-specific serial commands

PRODUCT WARRANTY

LIMITED ONE (1) YEAR WARRANTY ON STEWART FILMSCREEN CORP PROJECTION SCREENS SYSTEM

STEWART FILMSCREEN CORPORATION (Stewart) warrants its screens to the original purchaser only, to be free from defects in materials and workmanship for a period of one (1) year from the date of purchase by the original purchaser or eighteen (18) months from date of manufacture, as defined in the serial number, provided they are properly operated and maintained according to Stewart instructions and are not damaged due to improper handling or treatment after shipment from the factory.

This warranty does not apply to equipment showing evidence of misuse, abuse, or accidental damage, including neglect caused by improper installation (i.e. proximity to hot lights, exposure to extreme heat or cold, exposure to excessive humidity, etc.) as well as product that have been tampered with or repaired by any person or third party installation, other than authorized Stewart personnel.

Stewart's sole obligation under this warranty shall be to repair or to replace (at Stewart's sole discretion) the defective part of the merchandise. This warranty expressly does not cover any costs of removal, installation, framing, or other costs incident to replacing the screen or returning it to Stewart. Returns for service should be made to your Stewart dealer. If it is necessary for the dealer to return the screen or part to Stewart, transportation (freight) expenses to and from Stewart are payable by the purchaser and Stewart is not responsible for damage in shipment. To protect yourself against damage or loss in transit, insure the product and prepay all transportation expenses.

This warranty is in lieu of all other warranties, expressed or implied, including warranties as to fitness for use and merchantability. Any implied warranties of fitness for use, or merchantability, that may be mandated by statute or rule of law are limited to the one (1) year warranty period. This warranty gives you specific legal rights, and you may also have other rights which vary from state-to-state. In no event will Stewart be liable for sums in excess of the purchase price of the product. No liability is assumed by Stewart for expenses or damages resulting from interruption in operation of equipment, or for incidental, direct, or consequential damages of any nature.

In the event that there is a defect in materials or workmanship of a Stewart Screen, you may contact our Customer Service Department at 1161 W Sepulveda Blvd, Torrance, California 90502-2797 (310-784-5300) Toll free (800-762-4999).

IMPORTANT: This warranty shall not be valid and Stewart shall not be bound by this warranty if the product is not operated and maintained in accordance with Stewart's written instructions.

Stewart Filmscreen Corporation shall not be liable for any and all consequential damage(s) occasioned by the breach of any written or implied warranty pertaining to the sale in excess of the purchase price of the product sold.

Printed in USA. Rev. 12/14/10

Stewart[®]
F I L M S C R E E N

800.762.4999 • 310.784.5300 • Fax: 310.326.6870

www.stewartfilmscreen.com

January 2011
Printed in U.S.A.
©2000–2011 Stewart Filmscreen Corporation