

Model B & Model C Electriscreens

Owner's Manual



- TO THE OWNER
- INSTALLATION INSTRUCTIONS
- OPERATING THE SCREEN
- MAINTENANCE



Printed in U.S.A.

©2004–2011 Stewart Filmscreen Corporation

Stewart Filmscreen reserves the right to make changes to the product specified in this document.

From time to time, this document is updated. Current versions of documentation are posted on the Stewart Filmscreen website at:

www.stewartfilmscreen.com

Model B & Model C Electriscreens

Owner's Manual

Contents

To the Owner	2
Preparing the Installation	2
Step 1. Hanging the Case	5
Step 2. Electrical Hook-up	6
Operating the Screen	8
Adjusting the Screen Extension	9
Screen Care and Cleaning	11
Troubleshooting	12
Product Warranty	13

TO THE OWNER

Congratulations on your purchase of the finest optical viewing screen available anywhere in the world!

Please take a moment to review this manual, it will help ensure you many years of trouble-free service from your new Stewart Filmscreen product.

About your Model B/Model C Series Electriscreen

Your Model B & Model C Electriscreens offer the most technologically advanced roller screens in the world.

The maximum overall screen dimensions of the Model B are 18' high by 26'6" wide (5.5 m x 8.1 m).

The maximum overall screen dimensions of the Model C are 25' high by 38'10" wide (7.6 m x 11.8).

PREPARING THE INSTALLATION

- ◆ **Before proceeding with the installation of this screen, take time to thoroughly read and understand these installation and operation instructions.**
- ◆ **All electrical wiring installations must conform to local and national codes and should be performed by qualified service personnel.**
- ◆ **There are no user-serviceable parts contained within the unit.**

Preparation

Specifications regarding the individual screen dimensions, weight, mounting type, and controls are provided by the factory when the unit is ordered.

Before beginning the installation:

- ◆ Check the specifications for the type of mounting and switch control to be used.
- ◆ Ensure that the mounting area and electrical connection are prepared.
- ◆ Check the size and weight of the screen to be installed so that you can plan for the number of people required for the mounting procedure. You need at least four people to mount the smaller screens; more are needed for larger, heavier screens.

You will need:

- ◆ Enough ladders for the personnel supporting the screen during the mounting process
- ◆ A level
- ◆ Fasteners appropriate for the surface on which the screen is being mounted
- ◆ 2 block and tackles or scissor lifts to raise the unit into place
- ◆ Standard screwdriver
- ◆ 7/16" (1.1 cm) hex head screwdriver

Note: This manual refers to "AC" to represent electrical power. Your location may use 120 V, 220 V, or other electrical power. Screen systems are manufactured using the electrical power type specified for the location. Use appropriate power sources for your location.

Factory Advisory

The factory advises against installing a concealed or recessed electrical projection screen permanently. You must be able to access and remove the unit should future service be necessary.

Suggested solutions for removing the unit include:

- ◆ A removable ceiling cover plate under the mounting location.
- ◆ Access to the unit through an attic or overhead space.

Unpacking

Warning!

Failure to remove the batten lock-down screws can result in permanent damage to the screen.

1. DO NOT remove the paper hanging from the trapdoor at this time. You should remove it only after the unit is hung, all electrical connections have been made, and the screen is in operation.
2. Remove the batten lock-down screws located on the back side of the case.

STEP 1. HANGING THE CASE

Professional mounting techniques should be used. Stewart Filmscreen Corporation cannot be liable for substandard or faulty installations.

Make sure that you mount the screen so that the electrical box is on the left side (audience left).

Installing the unit

The Model B and Model C Electriscreens are ready to install into the ceiling or soffit. A false ceiling is not intended to support the weight of a Model B and Model C Electriscreens.

The screen can be bolted directly to the support structure or suspended. If the unit is to be mounted to plaster, drywall, masonry, or other type of surface, use an appropriate fastener. (These might include toggle or molly bolts or similar fasteners.)

1. Install the unit onto the support structure making sure that the bottom of the case is flush with the finished ceiling, if any.
2. Make sure the unit is level.

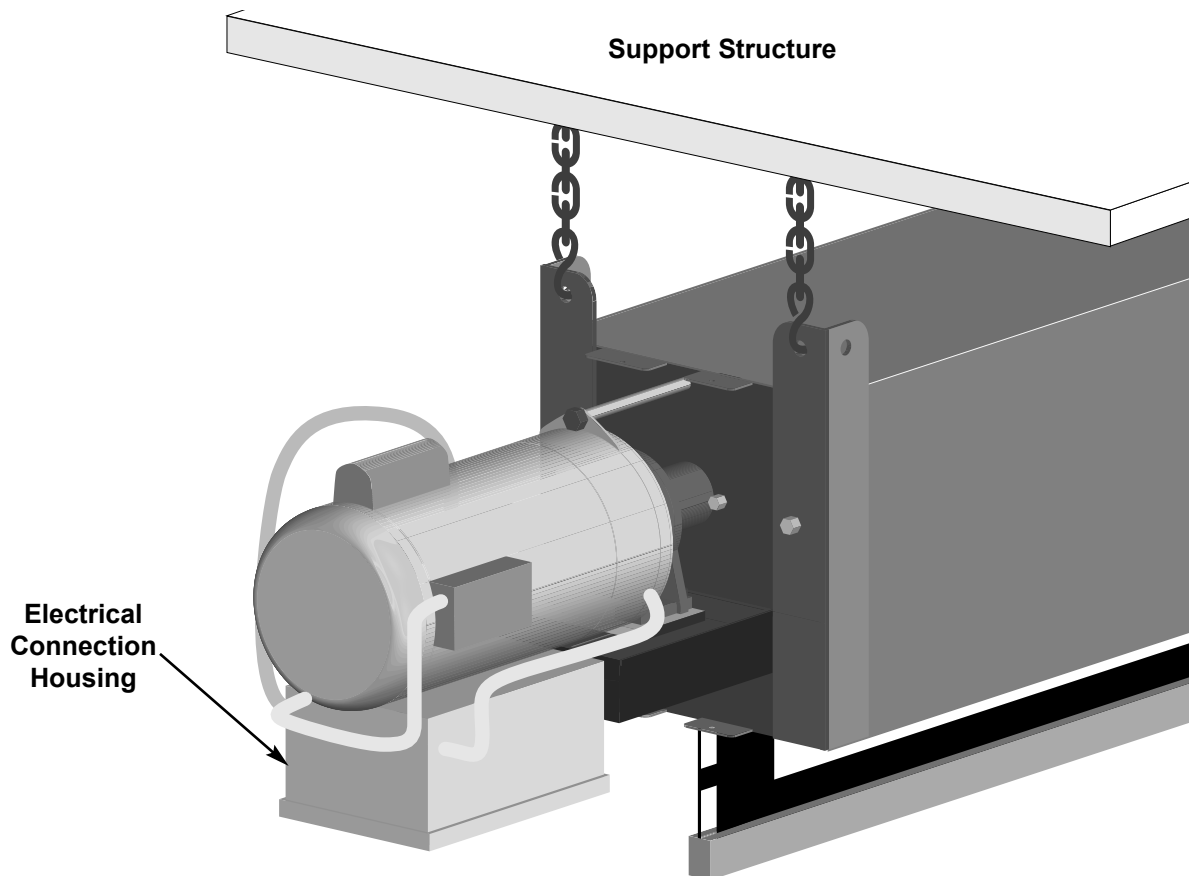

Figure 1: Model B & Model C Electriscreens

STEP 2. ELECTRICAL HOOK-UP

Caution

Professional techniques need to be used when making any electrical connection. A qualified electrician should perform these procedures.

Be sure to follow all standard safety procedures for installing electrical devices.

Do not disassemble or alter the configuration of the motor or the unit's electrical connections. This may cause injury to you or damage to the product.

The electrical connection should be made only to the type of power source indicated on the marking label.

The motor requires standard AC input (unless an alternate voltage has been specified). All connections are made to the electrical box on the side of the unit (audience left).

There are several kinds of switch controls available. Follow the installation procedure for the type of switch control you will install.

General suggestions for wiring:

- ◆ Soldering is recommended.
- ◆ The use of wire nuts is acceptable.

Installing the low-voltage 3-button switch (standard)

The Stewart Filmscreen low-voltage control allows the use of low-voltage wire to connect to the supplied 3-position 24V momentary wall switch.

Preparing the connection

Before making the electrical connections, you need:

- ◆ An available AC constant power source
- ◆ A 4-conductor switch hook-up cable (4-conductor bell wire or category 5 cable is typically used for long runs)
- ◆ Cat 5, multi-conductor unshielded, or similar type electronic cable can be used to connect the 3-button switch to the LVC. The recommended wire gauge is 20 to 24 AWG. Use plenum-rated cable when required.



Making the connection

Figure 2 illustrates the connections.

1. Remove the J-box covers, using a standard screwdriver.
2. Connect the 4-conductor cable to the connection harness coming from the J-box used for switch input, via an electrical knockout.
3. Connect the hookup cable to the 3-button switch.
4. Connect the main AC power source to the the J-box used for the main AC power connection, via an electrical knockout.
5. Replace the covers on the J-boxes.
6. A parallel connection to an outboard audio-visual switching network can be made at this time. (optional)

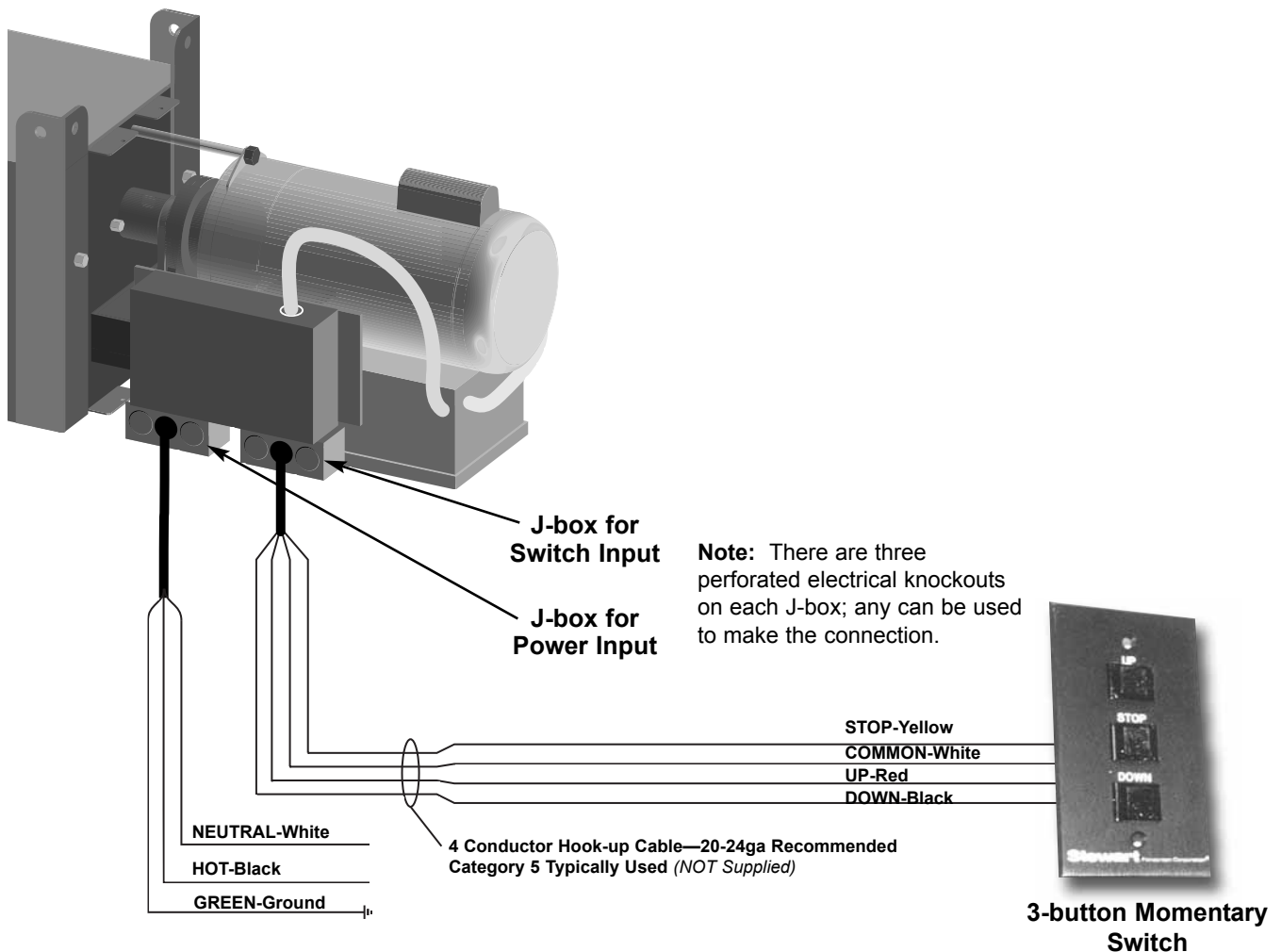

Figure 2: Low voltage 3-button switch wiring

OPERATING THE SCREEN

First time operation

The first time you operate the screen, the protective paper will fall out as the screen unrolls. Once the screen is fully displayed, make sure that no packing paper remains on the screen roll. The screen can be damaged if loose paper remains.

Use the 3-button switch or outboard switching network to control the screen.

When you lower or retract the screen, it will stop at its preset limit. If an obstacle (such as a person or furniture) gets in the path of the screen as it is lowered, you should use the switch control to stop the screen's motion; it will not automatically stop if it hits an obstacle.

In general, when the screen is not in use, you should store it in the fully retracted position.

Caution

Do not operate the motor when any of the following occurs:

- ◆ **The unit emits any smoke, heat, abnormal noise or unusual odor.**
- ◆ **The unit is damaged in some way, such as damage from a water leak.**

If any of these situations occur, call a qualified service person.

ADJUSTING THE SCREEN EXTENSION

Caution

Improper adjustment of the limits can cause irreparable damage to the screen itself, resulting in voiding the factory warranty.

The extension and retraction limits have been preset at the factory. In general, we advise you to avoid readjusting these limits.

In some cases, to enable proper alignment of the displayed image on the screen, you may need to adjust the extension of the screen. If adjustment to the extension is necessary, carefully follow these instructions.

Warning!

The screen is fully retracted when the batten is flush with the bottom of the case. Do not attempt adjustments with the blue retraction (UP) thumbwheel that will further retract the screen. Incorrect adjustment of the thumbwheel will cause severe screen damage. Please consult the factory if you have any questions.

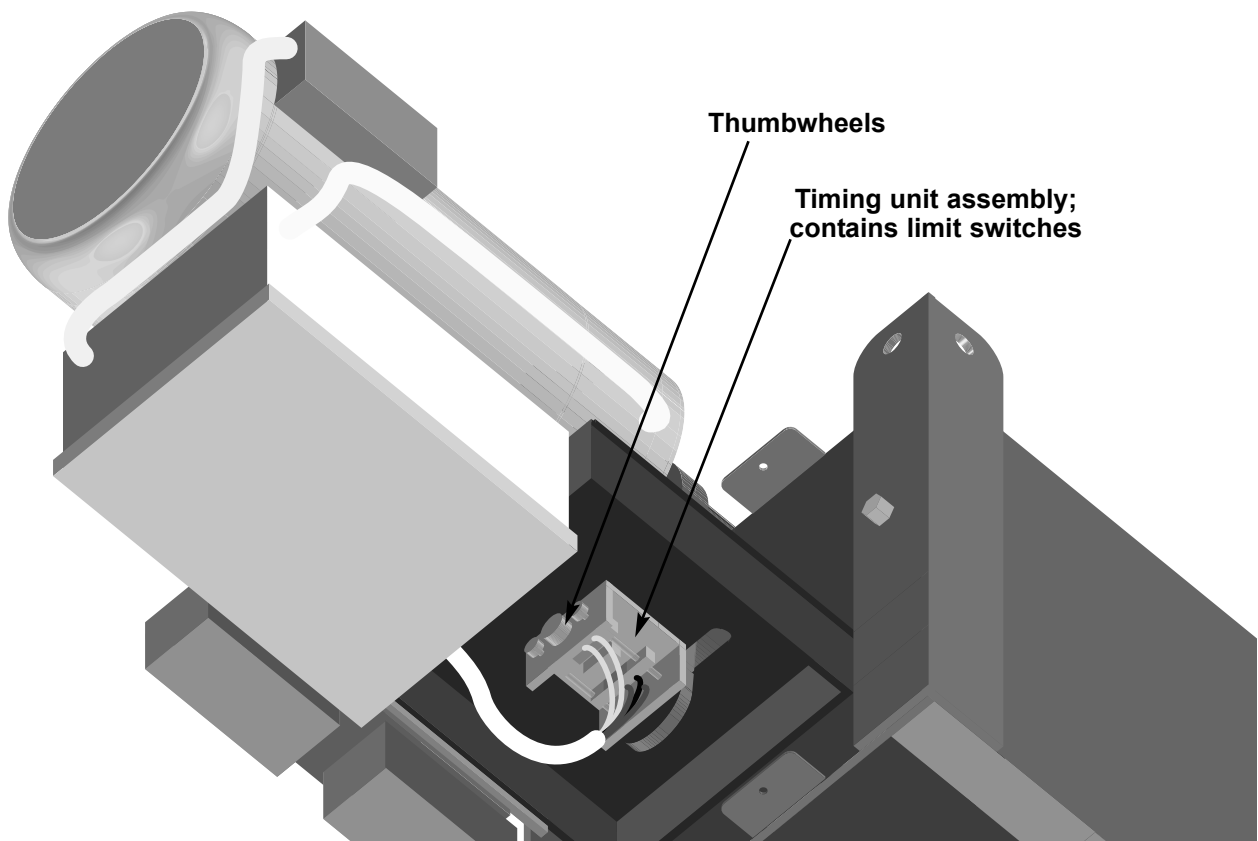

Figure 3: Underside view

Modifying the extension of the screen

You can increase the extension of the screen up to 3" (7.6 cm) past the factory preset stop, or you can decrease the extension by approximately 4-6" (10-15 cm) from the factory preset stop. Do not attempt to modify the screen extension beyond these recommended amounts.

The thumbwheels are located on the left side of the screen roller tube inside the case, as shown in Figure 3. Remove the cover of the case using a hex head screwdriver. When finished, replace the cover.

To increase the screen's fully extended (screen down) stop position:

1. Lower the screen to its current stop position.
2. Locate the red extension (down) thumbwheel located on the left side of the screen tube. Turn the thumbwheel in the direction of the (+) sign. If the power is on, the screen will drop incrementally as the thumbwheel is turned.

Note: One complete turn of the thumbwheel will make approximately a 3/4" (2 cm) change in the screen's stop position.

To decrease the screen extension:

1. Lower the screen until it is extended about halfway down.
2. Locate the red extension (down) thumbwheel located on the left side of the screen tube. Turn the thumbwheel in the direction of the (-) sign.

Note: One complete turn of the thumbwheel will make approximately a 3/4" (2 cm) change in the screen's stop position.

3. Activate the screen in the down direction until it reaches the newly reduced stop position. Repeat this procedure until the desired stop position is reached.

Once you have made the adjustment, whenever you lower the screen, it will automatically stop at the new position.

Note: It is recommended that you make a note of any changes made to the factory preset.

SCREEN CARE AND CLEANING

With reasonable care, you may expect many years of trouble-free use of your Stewart projection screen.

We encourage you to keep your screen clean. To protect your screen when it is not in use, store it in the fully retracted position.

Avoid getting any foreign material on the screen, as cleaning may prove very difficult. It may not be possible to remove scratches, paint, ink, etc.

General maintenance

The screen surface on your screen is delicate. Special attention to these instructions should be followed when cleaning.

- ◆ A draftsman-style brush may be used to lightly whisk away any loose dirt or dust particles. (This type of brush is usually available at office supply stores.) Stewart Filmscreen has an optional screen cleaning kit that contains the proper type of brush. Contact your dealer if you would like to obtain this cleaning kit.
- ◆ Particles left on the screen when it is retracted into the case may form an impression on the screen surface. Periodically wipe the back of the screen with a clean damp cloth.
- ◆ For tougher spots, use a solution of mild detergent and water. Rub lightly using a sponge. Blot with a damp sponge to absorb excess water. Residual water marks will evaporate within a few minutes. Let the screen air dry completely before retracting.

Do not use any other cleaning materials on the screen. Contact the factory if you have questions about removing difficult spots.

Replacement parts and service

No user-serviceable parts are contained within the unit. Contact your dealer or the factory if you require part replacement or service.

TROUBLESHOOTING

Refer to the following guidelines if you encounter a difficulty in the operation of your Stewart Filmscreen. Problems related to electrical or motor function may require a qualified service person or electrician.

Should you have a problem that is not addressed here, call the Stewart Filmscreen Corporation.

Problem description	Probable cause	Action to take
Screen won't operate.	No AC power available. Outboard switching problem.	Check to see if the circuit breaker has switched off. Reset if needed. Check outboard switching apparatus. Check voltage availability. Contact an electrician.
Screen won't roll up or down (even though power is available).	Bad connection at switch.	Have an electrician or qualified service person check the <i>low voltage control</i> switch-line connections.
Screen roller chatters when power is activated.	Can be caused by voltage drop, bad connections, or a defective switch.	Have an electrician or qualified service person check all hook-ups including all outboard wiring.
Unit hums in up mode. (Screen has already retracted.)	The screen batten is retracting too far into the case. Failure to correct can damage motor and screen. Do not use the unit until this problem is resolved.	Have a qualified service person adjust the blue UP extension thumbwheel. See pp. 9-10 of this manual.
Screen drops when up direction is activated (grinding noise occurs).	Drop in voltage.	Screen motor requires full voltage. Have an electrician or qualified service person check available voltage.
Screen continues past bottom stop position.	Red extension thumbwheel is out of adjustment.	Readjust the red DOWN extension thumbwheel. See pp. 9-10 of this manual.
Batten retracts too far into case.	Blue extension thumbwheel is out of adjustment. Failure to correct can damage motor and screen. Do not use the unit until this problem is resolved.	Have a qualified service person readjust the blue UP extension thumbwheel.
Dirt, finger prints, marks, etc. on screen surface.	Improper handling of screen.	Brush off or use a mild detergent solution with clean rag or cotton swab.
Indentations appear on screen surface.	Debris or particles adhering to screen due to static cling.	Check back of screen; gently brush debris away by hand.

PRODUCT WARRANTY

LIMITED ONE (1) YEAR WARRANTY ON STEWART FILMSCREEN CORP PROJECTION SCREENS SYSTEM

STEWART FILMSCREEN CORPORATION (Stewart) warrants its screens to the original purchaser only, to be free from defects in materials and workmanship for a period of one (1) year from the date of purchase by the original purchaser or eighteen (18) months from date of manufacture, as defined in the serial number, provided they are properly operated and maintained according to Stewart instructions and are not damaged due to improper handling or treatment after shipment from the factory.

This warranty does not apply to equipment showing evidence of misuse, abuse, or accidental damage, including neglect caused by improper installation (i.e. proximity to hot lights, exposure to extreme heat or cold, exposure to excessive humidity, etc.) as well as product that have been tampered with or repaired by any person or third party installation, other than authorized Stewart personnel.

Stewart's sole obligation under this warranty shall be to repair or to replace (at Stewart's sole discretion) the defective part of the merchandise. This warranty expressly does not cover any costs of removal, installation, framing, or other costs incident to replacing the screen or returning it to Stewart. Returns for service should be made to your Stewart dealer. If it is necessary for the dealer to return the screen or part to Stewart, transportation (freight) expenses to and from Stewart are payable by the purchaser and Stewart is not responsible for damage in shipment. To protect yourself against damage or loss in transit, insure the product and prepay all transportation expenses.

This warranty is in lieu of all other warranties, expressed or implied, including warranties as to fitness for use and merchantability. Any implied warranties of fitness for use, or merchantability, that may be mandated by statute or rule of law are limited to the one (1) year warranty period. This warranty gives you specific legal rights, and you may also have other rights which vary from state-to-state. In no event will Stewart be liable for sums in excess of the purchase price of the product. No liability is assumed by Stewart for expenses or damages resulting from interruption in operation of equipment, or for incidental, direct, or consequential damages of any nature.

In the event that there is a defect in materials or workmanship of a Stewart Screen, you may contact our Customer Service Department at 1161 W Sepulveda Blvd, Torrance, California 90502-2797 (310-784-5300) Toll free (800-762-4999).

IMPORTANT: This warranty shall not be valid and Stewart shall not be bound by this warranty if the product is not operated and maintained in accordance with Stewart's written instructions.

Stewart Filmscreen Corporation shall not be liable for any and all consequential damage(s) occasioned by the breach of any written or implied warranty pertaining to the sale in excess of the purchase price of the product sold.

Printed in USA. Rev. 12/14/10

Stewart[®]
F I L M S C R E E N

800.762.4999 • 310.784.5300 • Fax: 310.326.6870

www.stewartfilmscreen.com

January 2011
Printed in U.S.A.
©2004–2011 Stewart Filmscreen Corporation