

# Rigid Rear Projection Screens

---

Owner's Manual

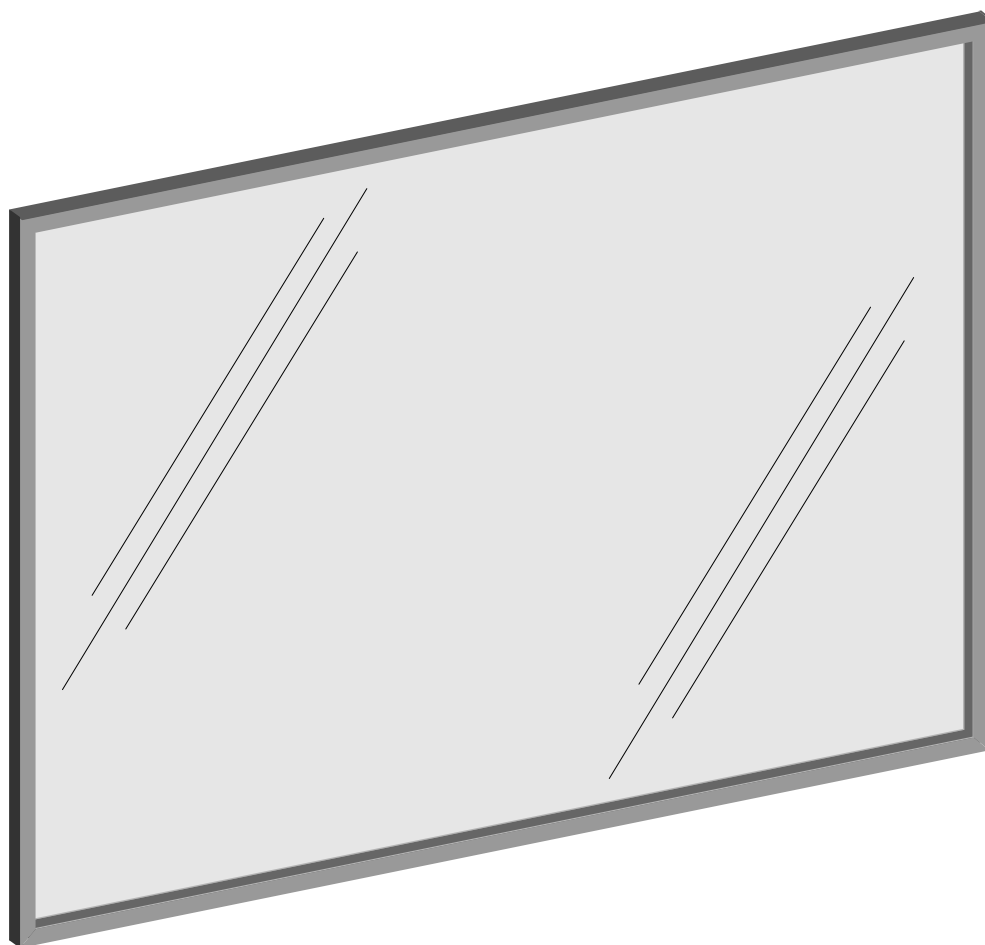

- TO THE OWNER
- INSTALLATION INSTRUCTIONS
- MAINTENANCE

Printed in U.S.A.

©2004–2011 Stewart Filmscreen Corporation

Stewart Filmscreen reserves the right to make changes to the product specified in this document.

From time to time, this document is updated. Current versions of documentation are posted on the Stewart Filmscreen website at:

[www.stewartfilmscreen.com](http://www.stewartfilmscreen.com)

# Rigid Rear Projection Screens

---

Owner's Manual

## **Contents**

---

To the Owner .....	2
Preparing for Installation .....	2
Installation .....	4
Frame Types .....	5
Screen Care and Cleaning .....	8
Product Warranty .....	9

---

## TO THE OWNER

---

Congratulations on your purchase of the finest optical viewing screen available anywhere in the world!

To create Rigid Rear Projection Screens, Stewart Filmscreen fuses advanced optical coatings to various glass and plastic substrates. This provides optimized image fidelity for any viewing environment.

Please take a moment to review this manual; it will help ensure you many years of trouble-free service from your new Stewart Filmscreen product.

---

## PREPARING FOR INSTALLATION

---

**Before proceeding with the installation of this screen, take time to thoroughly read and understand these installation and operation instructions.**

### Preparation

---

Specifications regarding the individual screen dimensions, weight, and frame type are provided by the factory when the unit is ordered. Before beginning the installation:

- ◆ Check the specifications for the frame type. Ensure that the aperture is the right size. (Refer to the section on frame types, starting on page 5.)
- ◆ Ensure that the area is prepared. In general, the screen should be installed after electricians, painters, carpet-layers, and other craftspeople have completed their work. This minimizes the risk of damage to the optical surface.
- ◆ Especially with large screens, ensure there is adequate access to the installation area (e.g., door heights, width of hallways, elevator capacity).
- ◆ Check the size and weight of the screen to be installed so that you can plan for the number of people and equipment required for the installation.

You will need:

- ◆ Clean gloves for handling the screen
- ◆ Suction cups of the type typically used by glass and window installers
- ◆ A level
- ◆ Appropriate fasteners (for installations that require them)
- ◆ Appropriate tools for any fasteners used
- ◆ Sufficient ladders, if required, for the personnel supporting the screen during the installation.
- ◆ A fork lift for very large or heavy screens

---

## **Alternative installation**

---

Stewart Filmscreen manufactures some very large, very heavy rigid screen systems. Frequently the assistance and expertise of professional glaziers is required to safely transport and install these screen and frame systems. Take note of the scale and weight of your screen system and determine if you should contract a glazing company for assistance.

Any screen exceeding 48" (122 cm) in height or 72" (183 cm) in width, or having a total weight above 100 pounds (45 kg), should be considered potentially challenging for typical installation crews, and your needs may be better served by a professional glazier. We offer this recommendation with the goal of protecting you, your personnel, the property, and the product. Stewart Filmscreen offers factory supervision and installation feasibility consultation on a fee basis and can manage your installation for you, upon request.

If you have any questions, contact Stewart Filmscreen Corporation.

---

# INSTALLATION

---

**Professional mounting techniques should be used. Stewart Filmscreen Corporation cannot be liable for substandard or faulty installations.**

## **General notes**

---

The screen and frame are typically shipped as one complete unit. In some instances, knocked-down, pre-drilled frame components and hardware are shipped ready for assembly.

In some cases, no frame is supplied, as the screen is built in as part of the installation.

## **Coated side**

---

One side of the screen has a special optical coating. Whenever possible, the screen should be installed with the coated side toward the audience. The picture is more pleasing because there is no imaging reflection of lighted objects in the audience. Exceptions are:

- ◆ Where the screen environment is uncontrolled and potential abuse of the coating is a concern.
- ◆ Screen marking pens are used during projection.

## **Unpacking and handling**

---

- ◆ Keep the screen protected until the environment is clean and there is no danger of damage to the optical coating.
- ◆ Open the crate as indicated, as this will expose the non-coated side of the screen.
- ◆ If the screen is already attached to the frame, do not lift the screen by the upper frame member, as the frame may pull off the screen, damaging the coating.
- ◆ Use suction cups to remove and install the screen. Use the suction cups only on the non-coated side of the screen.
- ◆ Keep hands and tools off the optical coating. Use cotton gloves when installing the screen.

## **Installing the screen in the aperture**

---

In general, the installation of a rigid rear projection screen is similar to the process used when installing a window in a house. Use care when handling the screen, especially the coated side, as mentioned above.

Once the screen is in place, make sure that it is level and plumb. Use shims as needed.

---

## FRAME TYPES

---

### **P1000, P1500, and P2000**

---

The P1000 frame requires a wall opening  $2\frac{5}{8}$ " (6.668 cm) larger in both height and width than the screen image size.

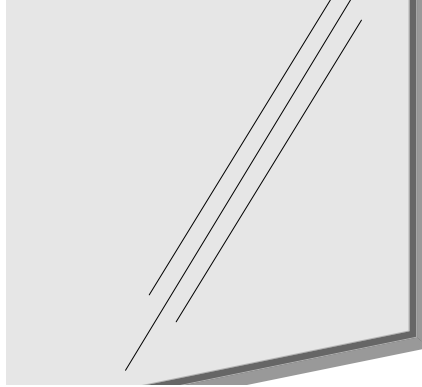

**Figure 1.** P1000

The P1500 frame requires a wall opening 3.5" (8.89 cm) larger in both height and width than the screen image.



**Figure 2.** P1500

The P2000 frame requires a wall opening 4" (10.16 cm) larger in both height and width than the screen image.



**Figure 3.** P2000

---

## Deluxe frame

---

The Deluxe frame is 3 1/4" (8.255 cm) wide, with mitered corners and a beveled edge. It can be set into a wall or cabinet. There are also free-standing or suspended (flying) systems.

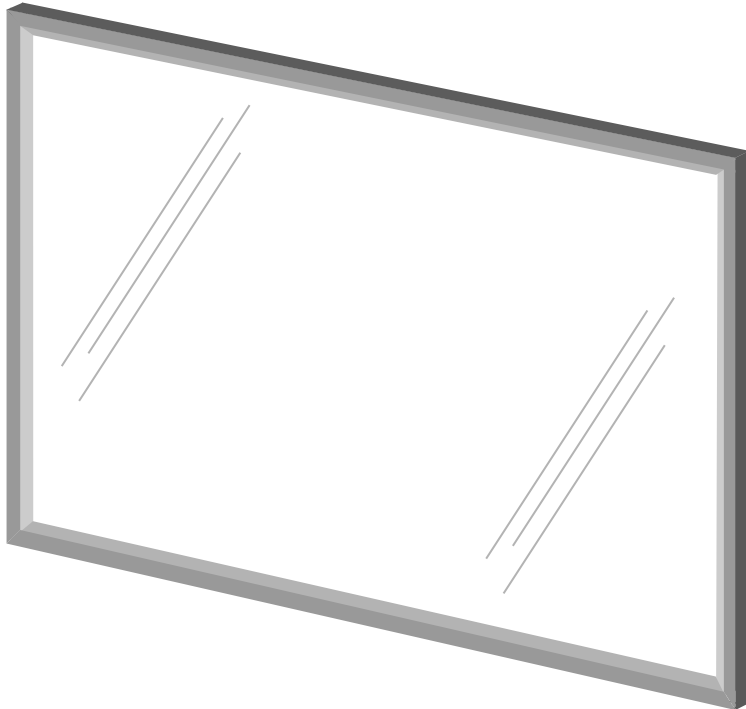

**Figure 4.** Deluxe frame

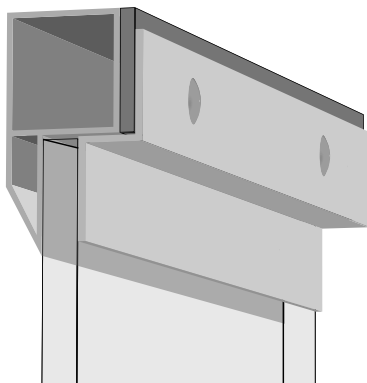

**Figure 5.** Cross section detail of Deluxe frame; top frame member

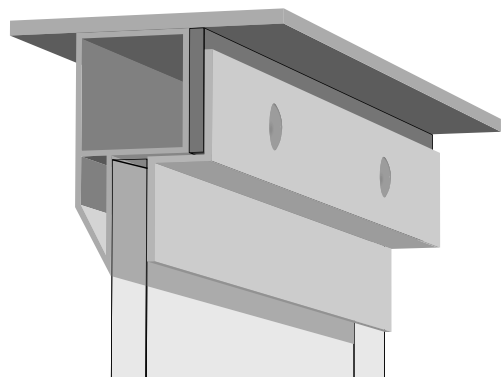

**Figure 6.** Cross section detail of suspended Deluxe frame; top frame member

---

## Wedge frame

The wedge frame is used in video walls, simulators, and command and control centers. The wedge profile tapers down on the image side to a knife edge where it contacts the screen.

Multiple wedge frames can be installed in a containment frame.

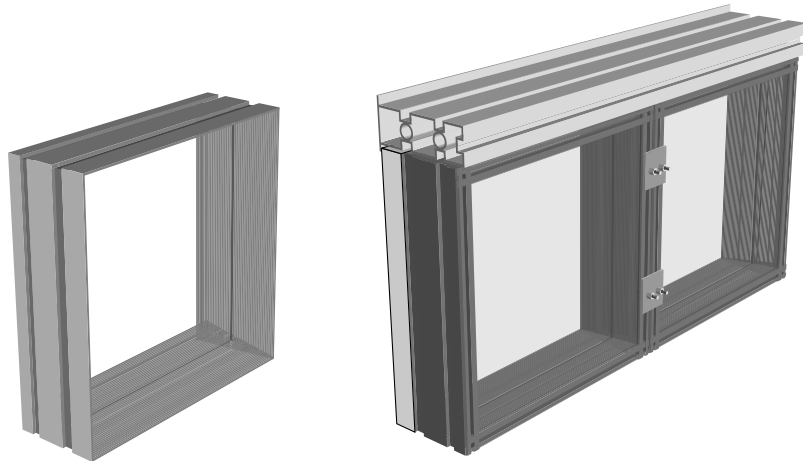

**Figure 7.** Wedge frame

**Figure 8.** Detail of two Wedge frames in a partial containment frame

---

## Quick-Stall

The Quick-Stall frame allows for easy installation of a rigid rear screen by eliminating the need for a finish trim. The Quick-Stall frame covers unfinished molding with a built-in 5/8" (1.6 cm) trim.

The Quick-Stall frame requires a wall opening 5" (12.7 cm) larger in both height and width than the screen image.

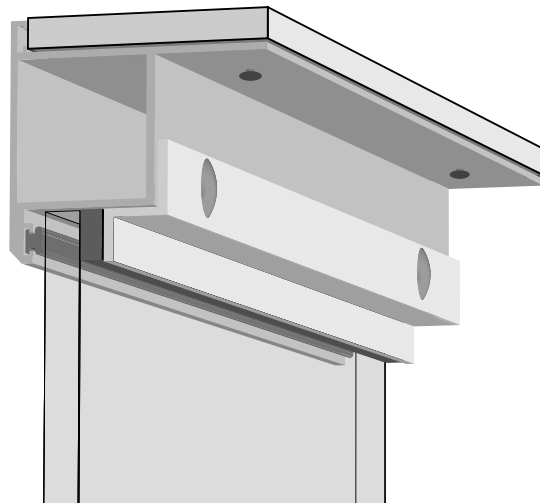

**Figure 9.** Quick-Stall

---

## **SCREEN CARE AND CLEANING**

---

With reasonable care, you may expect many years of trouble-free use of your Stewart projection screen.

We encourage you to keep your screen clean. Avoid getting any foreign material on the screen, as cleaning may prove very difficult. It may not be possible to remove scratches, paint, ink, etc.

### **General maintenance**

---

The uncoated side of the screen requires only the care normally given to glass or acrylic surfaces.

Pay special attention to these instructions when cleaning the surface with the optical coating.

- ◆ Use a draftsman-style brush to lightly whisk away any loose dirt or dust particles. (This type of brush is usually available at office supply stores.) Stewart Filmscreen has an optional screen cleaning kit that contains the proper type of brush. Contact your dealer if you would like to obtain this cleaning kit.
- ◆ For tougher spots, use a solution of mild detergent and water. Rub lightly using a sponge or clean cotton cloth. Do not use aggressive or excessive pressure as the optical characteristics could be degraded. Blot with a damp sponge to absorb excess water. Any residual water marks or streaks will evaporate in a few minutes.

Do not use any other cleaning materials on the screen, especially chemicals, solvents, and abrasive cleansers. Contact the factory if you have questions about removing difficult spots.

### **Replacement parts and service**

---

No user-serviceable parts are contained within the unit. Contact your dealer or the factory if you require part replacement or service.

---

## PRODUCT WARRANTY

---

### LIMITED ONE (1) YEAR WARRANTY ON STEWART FILMSCREEN CORP PROJECTION SCREENS SYSTEM

STEWART FILMSCREEN CORPORATION (Stewart) warrants its screens to the original purchaser only, to be free from defects in materials and workmanship for a period of one (1) year from the date of purchase by the original purchaser or eighteen (18) months from date of manufacture, as defined in the serial number, provided they are properly operated and maintained according to Stewart instructions and are not damaged due to improper handling or treatment after shipment from the factory.

This warranty does not apply to equipment showing evidence of misuse, abuse, or accidental damage, including neglect caused by improper installation (i.e. proximity to hot lights, exposure to extreme heat or cold, exposure to excessive humidity, etc.) as well as product that have been tampered with or repaired by any person or third party installation, other than authorized Stewart personnel.

Stewart's sole obligation under this warranty shall be to repair or to replace (at Stewart's sole discretion) the defective part of the merchandise. This warranty expressly does not cover any costs of removal, installation, framing, or other costs incident to replacing the screen or returning it to Stewart. Returns for service should be made to your Stewart dealer. If it is necessary for the dealer to return the screen or part to Stewart, transportation (freight) expenses to and from Stewart are payable by the purchaser and Stewart is not responsible for damage in shipment. To protect yourself against damage or loss in transit, insure the product and prepay all transportation expenses.

This warranty is in lieu of all other warranties, expressed or implied, including warranties as to fitness for use and merchantability. Any implied warranties of fitness for use, or merchantability, that may be mandated by statute or rule of law are limited to the one (1) year warranty period. This warranty gives you specific legal rights, and you may also have other rights which vary from state-to-state. In no event will Stewart be liable for sums in excess of the purchase price of the product. No liability is assumed by Stewart for expenses or damages resulting from interruption in operation of equipment, or for incidental, direct, or consequential damages of any nature.

In the event that there is a defect in materials or workmanship of a Stewart Screen, you may contact our Customer Service Department at 1161 W Sepulveda Blvd, Torrance, California 90502-2797 (310-784-5300) Toll free (800-762-4999).

**IMPORTANT:** This warranty shall not be valid and Stewart shall not be bound by this warranty if the product is not operated and maintained in accordance with Stewart's written instructions.

**Stewart Filmscreen Corporation shall not be liable for any and all consequential damage(s) occasioned by the breach of any written or implied warranty pertaining to the sale in excess of the purchase price of the product sold.**

Printed in USA. Rev. 12/14/10



---

800.762.4999 • 310.784.5300 • Fax: 310.326.6870

[www.stewartfilmscreen.com](http://www.stewartfilmscreen.com)

January 2011  
Printed in U.S.A.  
©2004–2011 Stewart Filmscreen Corporation