

Lace and Grommeted Screens

Owner's Manual

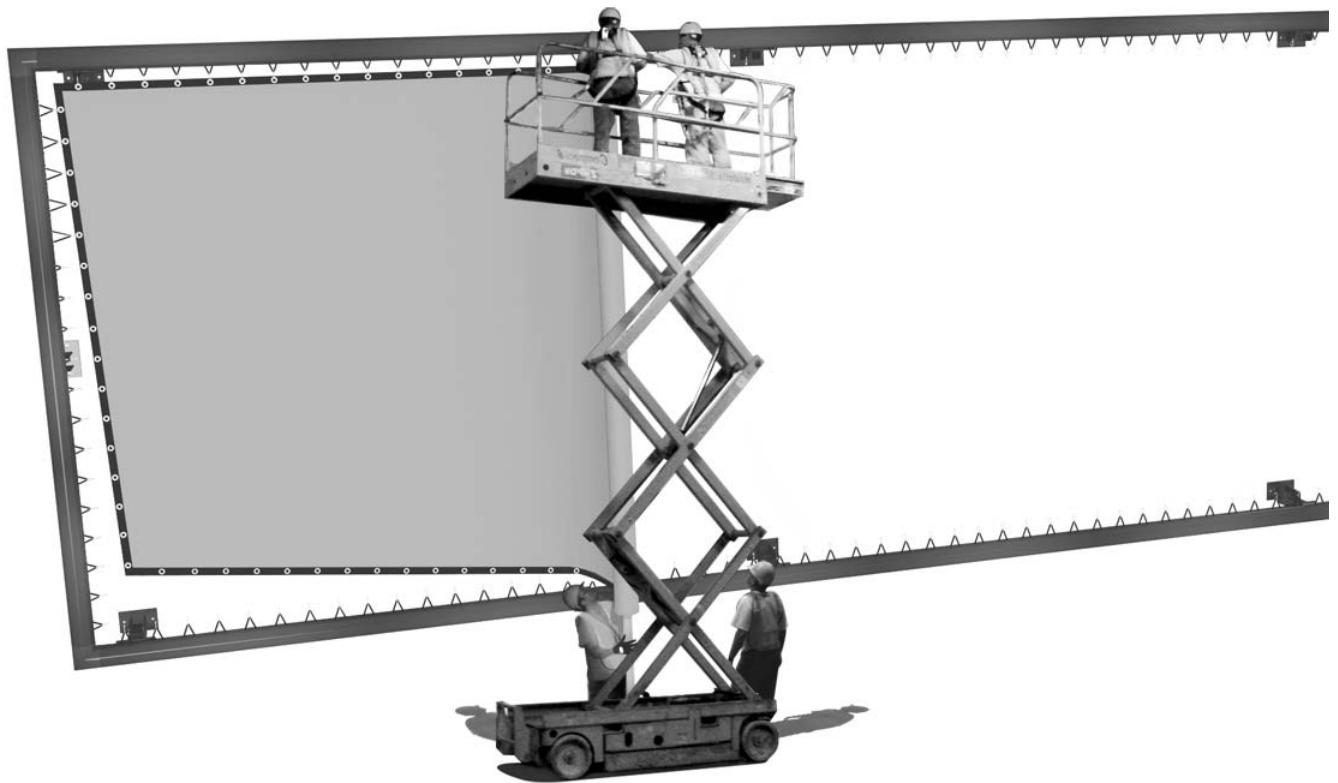

- TO THE OWNER
- INSTALLATION INSTRUCTIONS
- MAINTENANCE

Printed in U.S.A.

©2008–2011 Stewart Filmscreen Corporation

Stewart Filmscreen reserves the right to make changes to the product specified in this document.

From time to time, this document is updated. Current versions of documentation are posted on the Stewart Filmscreen website at:

www.stewartfilmscreen.com

Lace and Grommated Screens

Owner's Manual

Contents

To the Owner	2
Preparing the Installation	3
Installation: AT Frame	4
"This Screen Seems Too Small"	13
Installation: Screen with Owner-supplied Frame	14
Screen Care and Cleaning	16
Troubleshooting	16
Warranty for Screens Using Stewart Frames	17

Congratulations on your purchase of the finest optical viewing screen available anywhere in the world!

Please take a moment to review this manual—it will help ensure you many years of trouble-free service from your new Stewart Filmscreen product.

About your screen

The Lace and Grommeted screens use an AT frame with seamless tubing, heliarc welds, shock (stretch or bungee) cord, and S-hooks to secure the screen edge through grommets. Each screen is built to individual specification.

Note: An owner-supplied frame can also be used, but in this case the screen is not warranted.

Options

- ◆ Black masking borders absorb over-scanning and create a finished look, or screen material can wrap around the frame and attach on the back side (wraparound).
- ◆ Frames can be flat or factory-curved to any specified radius.
- ◆ The frame can be an AT2 or AT3 (2" or 3" / 5 or 7.5 cm diameter tubing, respectively).
- ◆ Mitered corners are standard, curved corners are optional.
- ◆ Mounting options include wall mounts, stage-fly bolts, or T-stands.

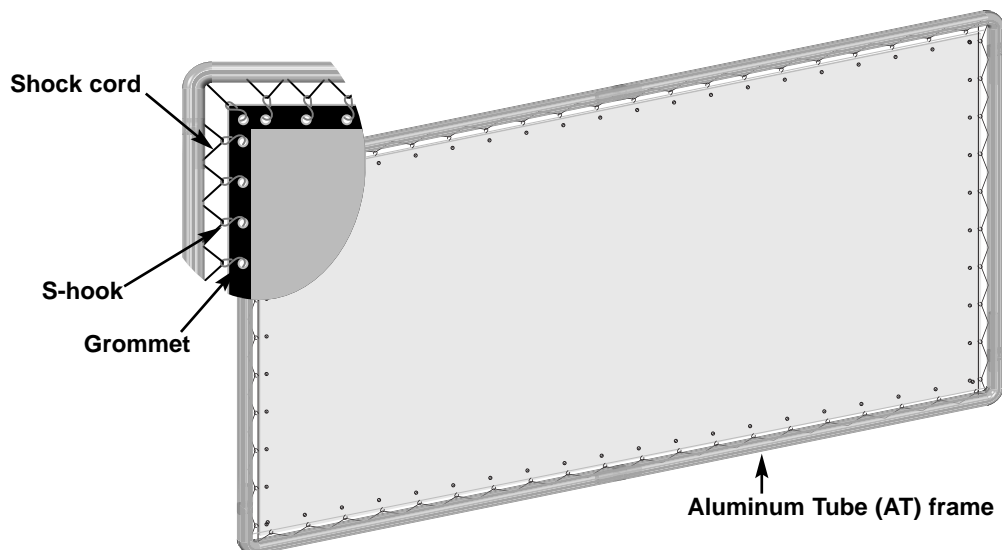

Figure 1. Assembled screen (curved corners, no masking); audience view

PREPARING THE INSTALLATION

Before proceeding with the installation of this screen, take time to thoroughly read and understand these installation and operation instructions.

Specifications regarding the individual screen dimensions, weight, and mounting are provided by the factory when the unit is ordered. Before beginning the installation:

- ◆ Check the specifications.
- ◆ Clear an area at least equal to the frame dimensions. Lay out clean paper or plastic as a clean work surface. (Screen or mask fabric will attract dust or dirt if the area is not clean.)
- ◆ Check the size and weight of the screen to be installed so that you can plan for the number of people required to move it. You need at least four people; more may be needed for larger, heavier screens.

For larger screens, you will need special equipment to support the screen tube and to elevate personnel to an appropriate height for attaching the screen to the frame.

You will need:

- ◆ For screens whose top is high off the ground, use a rolling scaffold, scissors-lift, or genie lift.
- ◆ For larger screens, use a crane or block-and-tackle to hoist screen tube into place and support it during installation.
- ◆ For smaller screens, use a 4-wheel equipment dolly to support the screen tube.
- ◆ Other items include:
 - Level
 - Tools to fasten bolts
 - Measuring tape
 - Cutters to cut tie-off cords

Be sure to read instructions completely before beginning. The general sequence for installation is:

- ◆ Assemble frame
- ◆ Assemble support (wall mount, stage-fly mount, or T-stand)
- ◆ Attach screen

Caution

During installation, do not place the components on an unstable cart, stand, table, or ladder. The item may fall, causing injury to a person and damage to the component.

Assembling the frame

Frame members and corners are numbered to make assembly easier.

1. As you unpack the frame, check the corners and tube ends for numbering.
2. On the clean work area, lay out the tubes; if masked, the masking side should be down. Make sure to align the corresponding numbered ends.

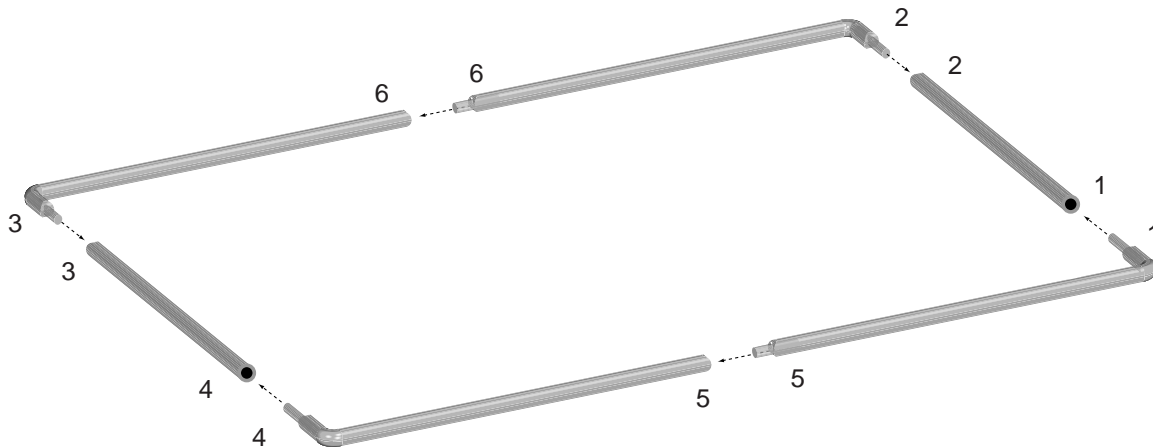

Figure 2. Frame members aligned according to numbered ends

3. Assemble the frame components using the supplied bolts. A back brace is used for front projection screens over 16' / 4.8 m wide that use a T-stand or stage fly mount.
4. Proceed to the instructions for the wall mount support system, stage fly mount, or the T-stand.

Note for larger frames

On larger frames, it may be necessary to install the frame directly to the mounted position.

- ◆ Mount one frame member at a time, assuring proper placement on the wall or in the aperture.
- ◆ Begin at the bottom corner and work across to complete the bottom. Then mount the side frame members followed by the top.
- ◆ As you proceed, check that frame members are level.

Wall mount support system

Note: You will temporarily elevate the frame into position so that you can mark the correct position for the wall brackets.

1. Attach wall support brackets to the assembled frame (this is temporary).
2. Establish a level horizontal line on the wall using a chalk line. The horizontal line should align with the bottom of the frame. The line will function as a constant for verifying accuracy of frame position.
3. Gather equipment, tools, and personnel to temporarily elevate the assembled frame into position. Be sure to precisely position the bottom frame referencing the chalk line.
4. Make sure that each frame member of the frame assembly is level and plumb. Check the diagonal measurements to verify that the assembly is square.
5. Mark the holes for each wall support bracket.
6. Lower the frame to the floor.
7. Remove the wall support brackets from the frame. Drill the locations marked on the wall to accept the appropriate fastener.
8. Attach the mounting brackets to the wall.
9. Curved frames use support tubes of different lengths (shorter in the center, longer at the end of the screen). Refer to Figure 5.
10. Gather equipment and personnel to mount the frame to the wall support assembly, using support tubes if required.

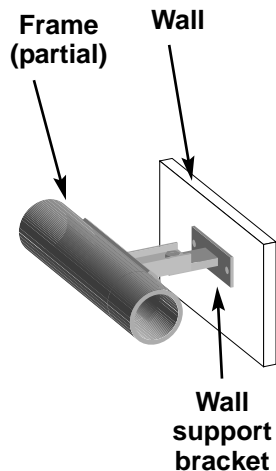

Figure 3. Wall mount for flat screen

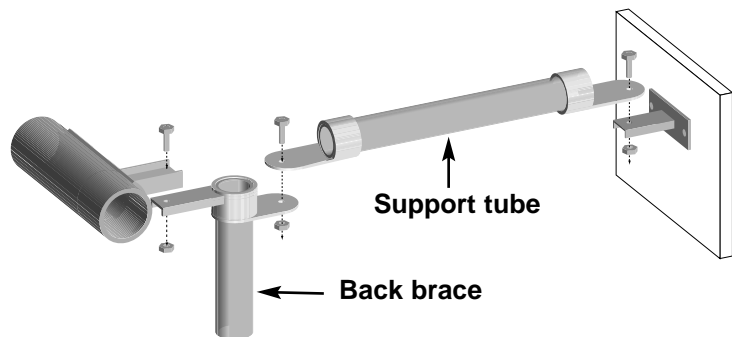

Figure 4. Wall mount for curved screen: Frame, back brace, support tube, wall bracket

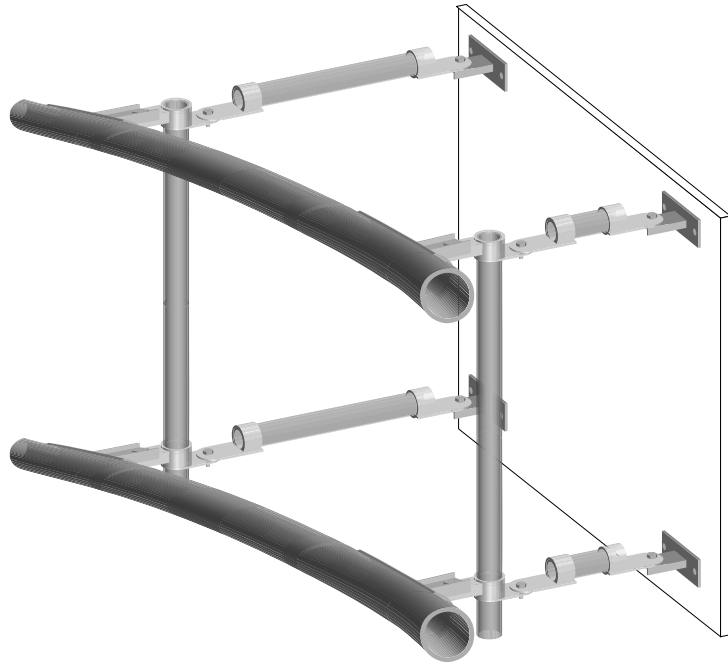

Figure 5. Wall mount for curved screen

Stage-fly mount

Eyebolts are attached to frame members at the factory. Gather equipment and personnel to elevate the frame and suspend it from the eyebolts.

Assembling the T-stand

Follow these steps to assemble the T-stand. A back brace may be used for larger screens.

1. Insert upright support posts into screen frame brackets and tighten. Refer to Figure 6.
2. Insert T-Stand bases into upright support posts and attach with bolts. Refer to Figure 7.
3. Attach cross braces to support standing T-stand posts. Refer to Figure 8.

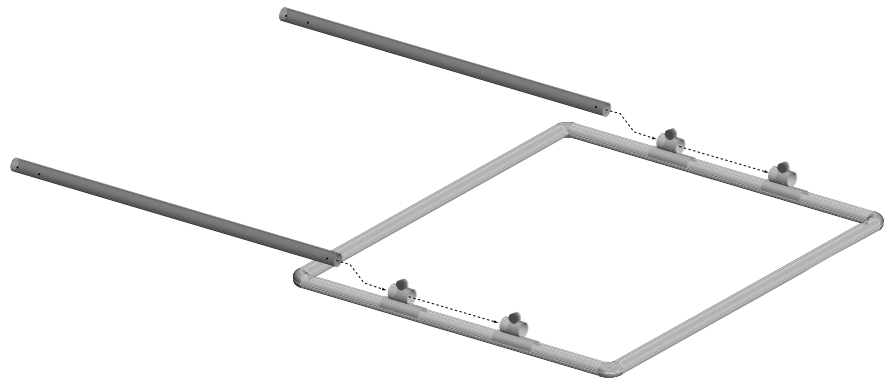

Figure 6. Inserting support posts

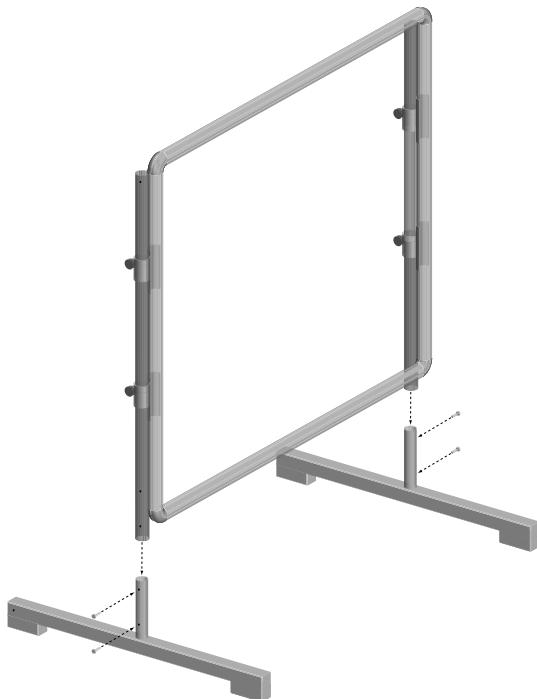

Figure 7. Attaching T-stands



Figure 8. Attaching cross braces

Attaching the screen to the frame—General procedure

The general procedure for attaching lace and grommeted screens to the frame is the same for all mounting and screen types. Specific notes for wraparound screens and owner-supplied frames follow this section.

Attach the screen to the top left corner of the frame first, then along the top, then the sides, then the bottom. Read the tips and follow the sequence.

Tips for attaching the screen to the frame

Read all instructions prior to beginning. Have all tools and equipment ready.

- ◆ During packing and transit, the screen may shrink. The Stewart screen material has some elasticity, and will stretch and spring back. The grommeted edge binding will not stretch past the manufactured outer dimensions. After the screen is attached to the frame, some tension will be apparent at each grommet. If you have concerns, read the section “This Screen Seems Too Small.”
- ◆ At least one person on a scaffold or lift and one person on the floor must work together to rotate the screen cylinder to unroll the screen. You may need another person on the ground to move the scaffold or lift.
- ◆ Handle the screen carefully. Avoid contact of the screen fabric with fingernails. Grasp the screen edge binding only.
- ◆ As you finish attaching each section, take a moment to pause and inspect the screen to ensure that it is not pulling or stretching in such a way that it may tear.
- ◆ On screens that use AC tape instead of black webbing along the grommeted edges, be sure to pull grommets on the same plane as the material. Do not rotate them as you pull or the edge of the grommet may slice through the material and tear the screen.

Caution

To avoid damage to the screen, use caution when handling the screen roll.

Carry the roll by the ends only. Do not place the screen roll on steps or any uneven surface as the pressure can make permanent indentations in the screen.

Preparing the screen tie-off cords

1. Carefully lay the rolled up screen on the floor.
2. Tie off the cords to the holes in the central packing tube. You can elevate the end of the screen for easier access, or straddle the tube on the floor. As you tie off the cords, you will need to lift and rotate the screen.

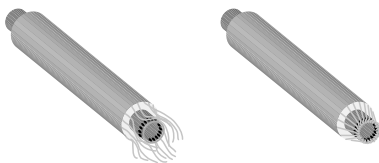

Figure 9. Screen with tie cords



Figure 10. Rigger attaching tie cords to tube end on elevated screen

Attaching the screen to the frame—steps

Follow the steps to attach the screen to the frame.

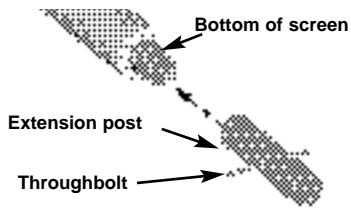

Figure 11. Optional extension post

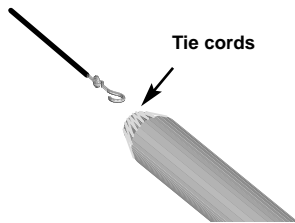

Figure 12. Screen top with cable from crane

1. If used, install the optional extension post to the bottom of the screen tubing. Set the height so that the bottom of the screen will be in the correct position once the screen is hoisted into place. Use the throughbolt to set the position. Refer to Figure 11.
2. For larger screens, attach the hoist or crane cable to the throughbolt in the top of the screen tube. Refer to Figure 12. For smaller screens, the tube can be supported by a rolling dolly instead of a crane.
3. Slowly raise the top of the tube to lift the screen into position while moving the bottom of the screen along the floor until the screen is in the vertical position at the audience left side of the frame.
4. If used, adjust the optional extension post at the bottom of the screen so that the screen is at the correct height.

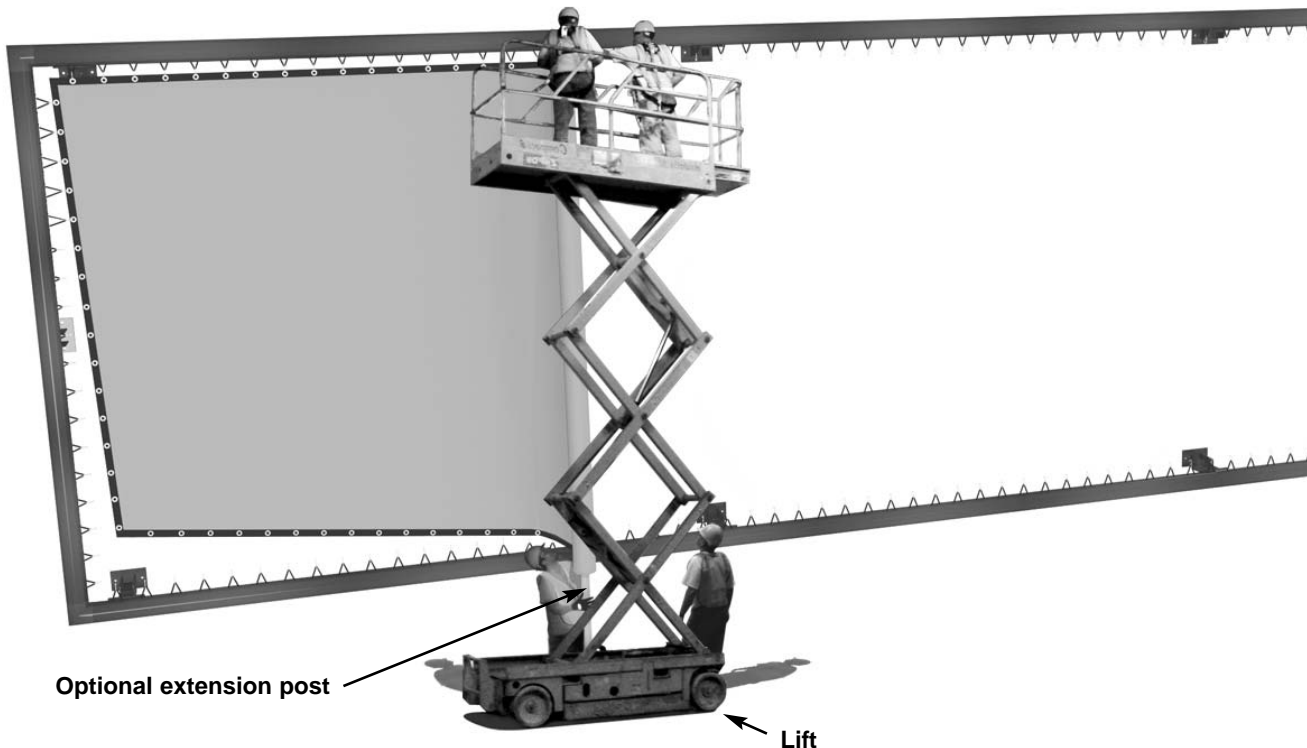

Figure 13. Beginning to attach screen to frame

5. Cut the first tie cord and unroll the screen so that the grommets on the left side of the screen are exposed. (Do not cut all tie cords at this time.)
 - ◆ Unroll the screen slowly making sure to cut each successive tie cord so that the screen is free to unroll.
 - ◆ Do not cut all the tie cords at once, as they support the screen until it is attached to the frame.

- ◆ You can cut one or two tie cords ahead of the attachment as the screen is unrolled so that there is no danger of pulling out a grommet when the screen is unrolled.
- ◆ As the screen is being unrolled, it will be necessary to slide the extension post (at the bottom of the screen) along the floor in order to keep the screen vertical.

6. Start at the top left corner, using the techniques described below. Refer to Figure 14.

Attach S-hooks to the grommets to make a proper corner fit. Starting at the top left corner, attach two to six hooks down the side and across the top. Do not allow the weight of the screen to rest on any one hook during this time.

7. Continue along the top, using the techniques described below.

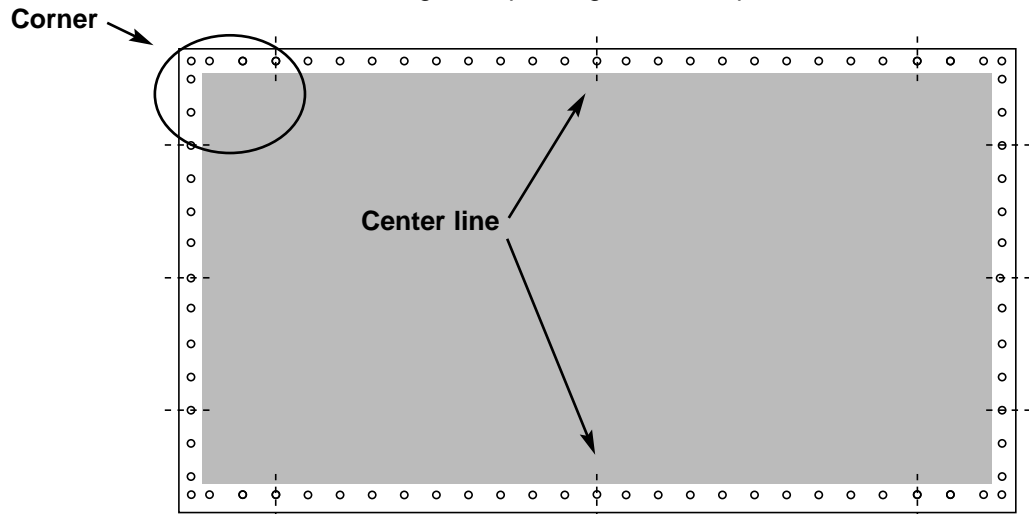

Figure 14. Screen, audience viewing side

Caution

Do not use excessive force to stretch the screen into place as this can cause the screen to tear.

Continue attaching S-hooks to grommets along the top from the top left to the center top. The screen center line is marked with a red grommet at the frame center. Refer to Figures 13 and 14.

As you work, continue to unroll the screen, cutting tie cords as required, and attaching S-hooks to grommets along the top. Inspect the screen to ensure that it is properly attached and not overstretched.

When the middle S-hook is attached to the center top grommet, the grommet should be within 3" / 7.5 cm of the center of the screen. If the center hook is short of the center grommet, continue attaching the hooks along the top until you reach the end. You will need to adjust the screen on the frame before attaching the sides. Shift the S-hooks one grommet at a time to

move the screen sideways on the frame. When the screen is centered on the frame, you can proceed with the sides.

You may need to skip three or four S-hooks to develop enough slack in the bungee cord to hook the grommet without creating too much tension. If you feel that you are pulling on the screen or the bungee too much, attach only the hooks that allow for minimal tension to give the material enough time to stretch before attaching the skipped hooks.

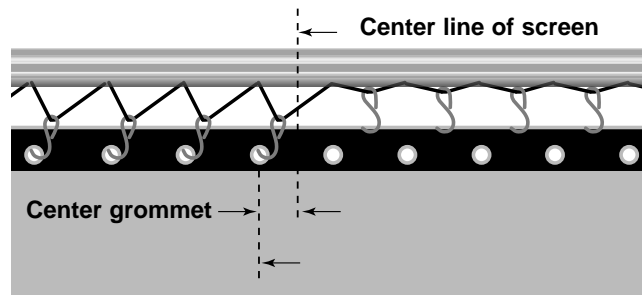

Figure 15. Top center of frame

8. Attach the screen to the sides of the frame, using the techniques described below.

Attach S-hooks on the right side from the top to the center. If the screen edge is more than 4" / 10 cm from the frame on the right side, allow a few minutes for the screen to stretch before continuing. Tension should be even; the top of screen and frame should be parallel.

Attach the S-hooks on the left side, from top to bottom.

Attach the S-hooks on the right side, from center to bottom.

9. Inspect the screen to ensure that it is properly attached and not overstretched. Check for even tension.
10. Attach the screen to the bottom of the frame, using the techniques described below. Begin attaching the bottom in the corners, being careful not to put too much tension on any grommets. Work toward the center.

You may need to skip three or four S-hooks to develop enough slack in the bungee cord to hook the grommet without creating too much tension. If you feel that you are pulling on the screen or the bungees too much, attach only the hooks that allow for minimal tension to give the material enough time to stretch before attaching the skipped hooks.

If there is too much tension, wait to allow the screen time to stretch as needed. Continue attaching the remaining S-hooks along the bottom, working toward the center.

11. Make a final inspection of the screen to verify that it is attached properly and that the corners are free from tears and stress.

Attaching a wraparound screen to the frame

Once you have assembled the frame, you can attach the wraparound screen to the frame. The general instructions are the same as for a non-wraparound screen with the following differences. Be sure to refer to the preceding instructions and cautions.

- ◆ The screen has been manufactured with an overall dimension of 8" / 20 cm larger than the frame size. When unrolling the screen vertically, the edge should be about 4" / 10 cm past the side of the frame.
- ◆ It is imperative that the screen edge is pulled up and over the frame as the S-hooks are attached to the grommets. Do not rely on the shock cord to pull the screen over.
- ◆ When properly attached, there will be no tension on the screen top between the edge of the screen and the drilled holes securing the shock cord to the frame.
- ◆ For smaller screens, you can lay the screen on a clean floor, audience side down, then lay the frame over the screen and attach the screen to the frame.

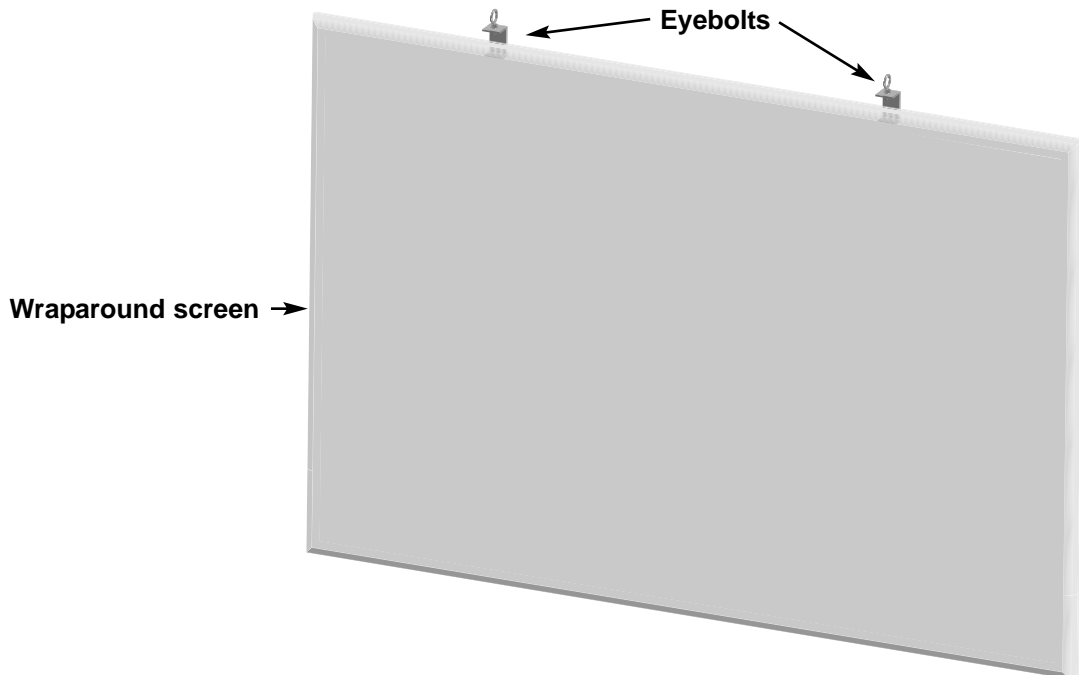

Figure 16. Wraparound screen with eyebolts for stage fly mount

"THIS SCREEN SEEMS TOO SMALL"

While the screen may seem too small for the frame, rest assured that it will fit. Grommeted screens manufactured by Stewart Filmscreen Corp. are unique in several ways. Stewart uses a proprietary process that allows seamless construction of all fabrics: front and rear projection, perforated and solid. The Stewart process provides the flattest, most uniform surface possible. The final step in achieving this surface occurs during installation, when the fabric is gently pulled into its final, specified dimension. This is accomplished by means of the shock cord and "S" hook framing system.

The vinyl sheet process creates an engineered, tensioned surface. This residual tension is what we call the "stretch" of the fabric. Large screens are bound using aircraft tape, which is applied while the screen is still on the manufacturing machinery. When the screen is further processed, the sheet contracts significantly as the fabric cures. Smaller screens are bound in a loft environment, where they are re-stretched to actual size. Some perforated fabrics are also bound in the loft after perforation.

Don't worry

It is normal and expected that a Stewart tension and grommet suspended screen appears to be too small for the frame as the screen is unrolled. This is correct and not a cause for worry. A rule of thumb is that for each 10 feet / 3 m of vertical height, approximately 8" / 20 cm of "stretch" is engineered into the fabric. Do not worry, this is exactly as planned.

This "stretch," coupled with the proprietary "un-reinforced vinyl sheet" construction, is what gives Stewart Filmscreen Corp. products their best-in-class lay-flat characteristics. A quick count of the grommets, which are laid out while the surface is at specified dimension during fabrication, will put your mind at ease.

Red grommet and hook at each center line

Stewart puts a red grommet at the center line of each perimeter edge of the fabric. The grommet spacing is 4" / 10 cm center to center. While installing the fabric, you may find that you've hit the red grommet exactly, or you may be off a grommet. If the layout is off a grommet, continue to hang the top, then go back and do a hook for hook exchange across the top. The remainder of the fabric will be fine "unhooked" for as long as this takes.

When the top binding of the screen is entirely suspended and centered in the frame, the fabric should be necking in toward the center from each edge, and significantly raised above the bottom frame member.

As you lace down the sides, the shock cord lacing system will easily come out and meet the screen edge and the screen fabric will quickly elongate to a perfect planar surface.

Lacing the bottom

For large scale screens, more than 15 feet / 4.5 m in height, it may be helpful to hook every third "S" hook across the bottom initially, then after a few minutes, start again at the center line, and begin hooking all the "S" hooks, this stretching process may take as much as an hour, but not more. It is helpful if the site is within normal human comfort temperatures, somewhere between 60 and 78 degrees F / 15.5 and 25.5 C.

INSTALLATION: SCREEN WITH OWNER-SUPPLIED FRAME

Caution

Screens used on owner-supplied frames are not covered by the Stewart product warranty. Extreme caution should be used when installing the screen.

If the owner-supplied frame is like the Stewart AT-type frame, use the instructions beginning on page 8. Be sure the frame dimensions are appropriate for the size of the screen.

Some owner-supplied frames use a peg-style attachment. These instructions provide information on installing the screen so that damage does not occur. The frame requires an accurate peg layout that matches the screen grommet layout starting at the screen center line. Refer to Figure 17.

Installers must know how to perform T-lacing (theater-lacing) to attach the screen to the peg-style frame.

Be sure you know the manufactured outer dimensions of the screen. Note them here:

Height: _____ Width: _____

Before beginning, measure peg to peg distance from top to bottom and from side to side. Compare measurements with screen dimensions. There should not be more than 5-6" / 12-15 cm total difference.

During packing and transit, the screen may shrink. When lacing the screen to the frame, DO NOT exceed these dimensions as corner damage will result. The warranty does not apply to torn corners or grommets.

The Stewart screen material has some elasticity, and will stretch and spring back. The lace cord is used as a means of attaching the material to a rigid frame. The grommeted edge binding will not stretch past the manufactured outer dimensions. After the screen is laced to the frame, some tension will be apparent at each grommet.

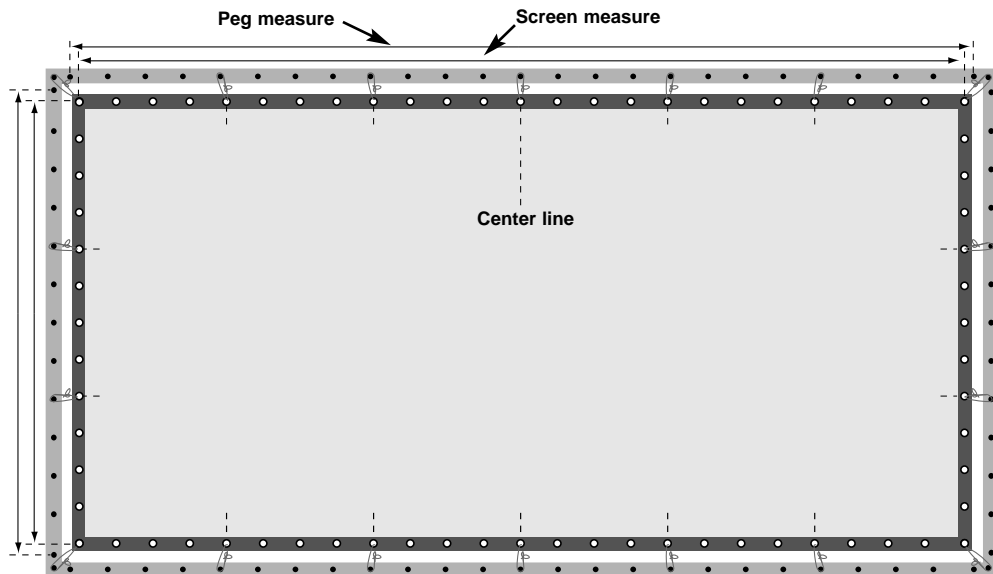

Figure 17. Alignment of screen and owner-supplied frame

Using T-lacing to attach the screen to a peg-type frame

Follow the same general procedure and cautions described in the section beginning on page 8. For a peg-style frame, instead of attaching S-hooks to grommets, use the T-lacing method.

1. Using the lace cord provided, lace the screen corner into pegs at the top left, and continue along the top towards the center using the T-lace method. Refer to Figures 18 and 19. The screen center line is marked with a red grommet at the frame center. Continue unrolling towards audience right. Make sure that the screen is centered in the frame.

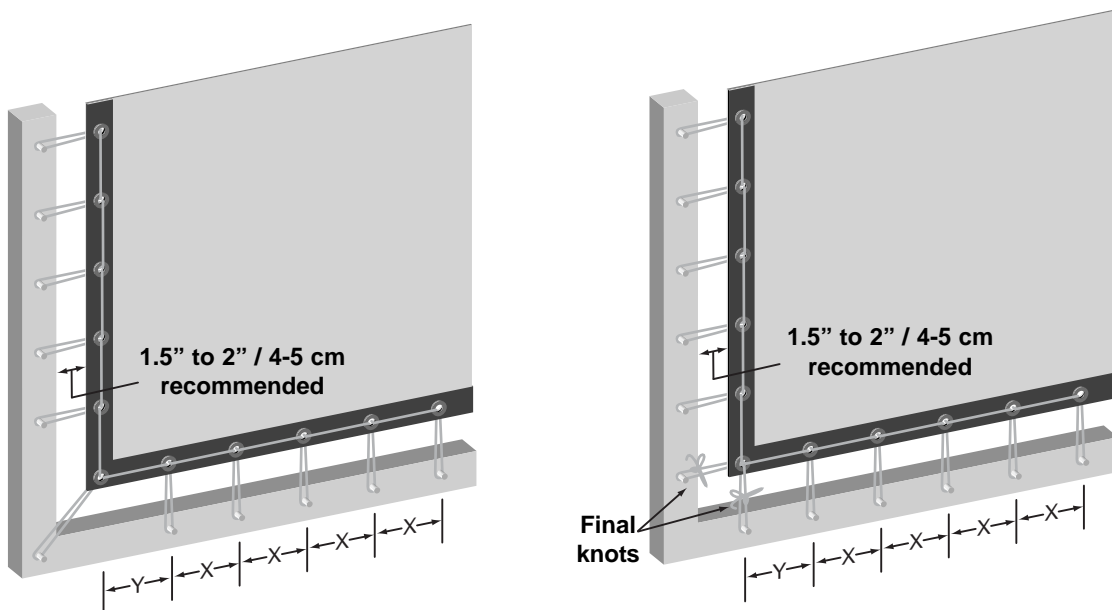

Figure 18. Proper methods of T-lacing

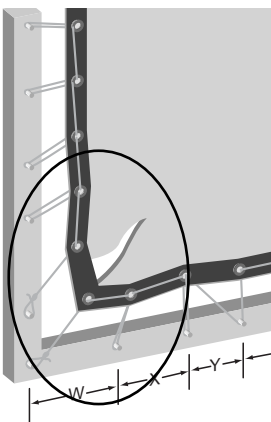

Figure 19. Improper method of lacing, unequal spacing, resulting in tear

2. Lace the left side 3-4 feet / 1 m down from the top and tie off.
3. Continue to unroll towards audience right, lacing along the top of the frame, using the T-lace method. The top webbing will stretch to the manufactured size.
4. Continue T-lacing the left side and then the right side from top to bottom. Use patience and care to allow the screen to stretch to the manufactured size.
5. Once the sides are laced, T-lace the bottom.
6. Make a final inspection of the screen to verify that it is attached properly and that the corners are free from tears and stress.

SCREEN CARE AND CLEANING

With reasonable care, you can expect many years of trouble-free use of your Stewart projection screen.

We encourage you to keep your screen clean. Avoid getting any foreign material on the screen, as cleaning may prove very difficult. It may not be possible to remove scratches, paint, ink, etc.

General maintenance

The surface of your screen is delicate. Special attention to these instructions should be followed when cleaning.

Caution

Do not use chemicals or solvents to clean the fabric.
--

- ◆ A draftsman-style brush may be used to lightly whisk away any loose dirt or dust particles. (This type of brush is usually available at office supply stores.) Stewart Filmscreen has an optional screen cleaning kit that contains the proper type of brush. Contact your dealer if you would like to obtain this cleaning kit.
- ◆ For tougher spots, use a solution of mild detergent and water. Rub lightly using a sponge. Blot with a damp sponge to absorb excess water. Residual water marks will evaporate within a few minutes. Let the screen air dry.

Do not use any other cleaning materials on the screen. Contact the factory if you have questions about removing difficult spots.

Replacement parts and service

No user-serviceable parts are contained within the unit. Contact your dealer or the factory if you require part replacement or service.

TROUBLESHOOTING

Refer to the following guidelines if you encounter a problem with your screen. Should you have a problem that is not addressed here, call the Stewart Filmscreen Corporation.

Problem description	Probable cause	Action to take
Dirt, fingerprints, marks, etc. on screen surface	Improper handling of screen	Brush off or use a mild detergent solution with clean rag or cotton swab.
Indentations on screen surface	Debris or particles adhering to screen due to static cling	Check back of screen; gently brush debris away by hand.
Tears in screen corner or side	Improper handling or attachment of screen to frame	Repair tear immediately to prevent further tearing. Use cellophane or mylar tape on the back side of the screen. For large tears, or tears that interfere with the projected image, contact the factory for a replacement screen.

PRODUCT WARRANTY FOR SCREENS USING STEWART FRAMES

LIMITED ONE (1) YEAR WARRANTY ON STEWART FILMSCREEN CORP PROJECTION SCREENS SYSTEM

Caution

Screens used on owner-supplied frames are not covered by the Stewart product warranty.

STEWART FILMSCREEN CORPORATION (Stewart) warrants its screens to the original purchaser only, to be free from defects in materials and workmanship for a period of one (1) year from the date of purchase by the original purchaser or eighteen (18) months from date of manufacture, as defined in the serial number, provided they are properly operated and maintained according to Stewart instructions and are not damaged due to improper handling or treatment after shipment from the factory.

This warranty does not apply to equipment showing evidence of misuse, abuse, or accidental damage, including neglect caused by improper installation (i.e. proximity to hot lights, exposure to extreme heat or cold, exposure to excessive humidity, etc.) as well as product that have been tampered with or repaired by any person or third party installation, other than authorized Stewart personnel.

Stewart's sole obligation under this warranty shall be to repair or to replace (at Stewart's sole discretion) the defective part of the merchandise. This warranty expressly does not cover any costs of removal, installation, framing, or other costs incident to replacing the screen or returning it to Stewart. Returns for service should be made to your Stewart dealer. If it is necessary for the dealer to return the screen or part to Stewart, transportation (freight) expenses to and from Stewart are payable by the purchaser and Stewart is not responsible for damage in shipment. To protect yourself against damage or loss in transit, insure the product and prepay all transportation expenses.

This warranty is in lieu of all other warranties, expressed or implied, including warranties as to fitness for use and merchantability. Any implied warranties of fitness for use, or merchantability, that may be mandated by statute or rule of law are limited to the one (1) year warranty period. This warranty gives you specific legal rights, and you may also have other rights which vary from state-to-state. In no event will Stewart be liable for sums in excess of the purchase price of the product. No liability is assumed by Stewart for expenses or damages resulting from interruption in operation of equipment, or for incidental, direct, or consequential damages of any nature.

In the event that there is a defect in materials or workmanship of a Stewart Screen, you may contact our Customer Service Department at 1161 W Sepulveda Blvd, Torrance, California 90502-2797 (310-784-5300) Toll free (800-762-4999).

IMPORTANT: This warranty shall not be valid and Stewart shall not be bound by this warranty if the product is not operated and maintained in accordance with Stewart's written instructions.

Stewart Filmscreen Corporation shall not be liable for any and all consequential damage(s) occasioned by the breach of any written or implied warranty pertaining to the sale in excess of the purchase price of the product sold.

Printed in USA. Rev. 12/14/10



800.762.4999 • 310.784.5300 • Fax: 310.326.6870

www.stewartfilmscreen.com

March 2011
Printed in U.S.A.
©2008–2010 Stewart Filmscreen Corporation