

Visionary Electriscreen

Owner's Manual

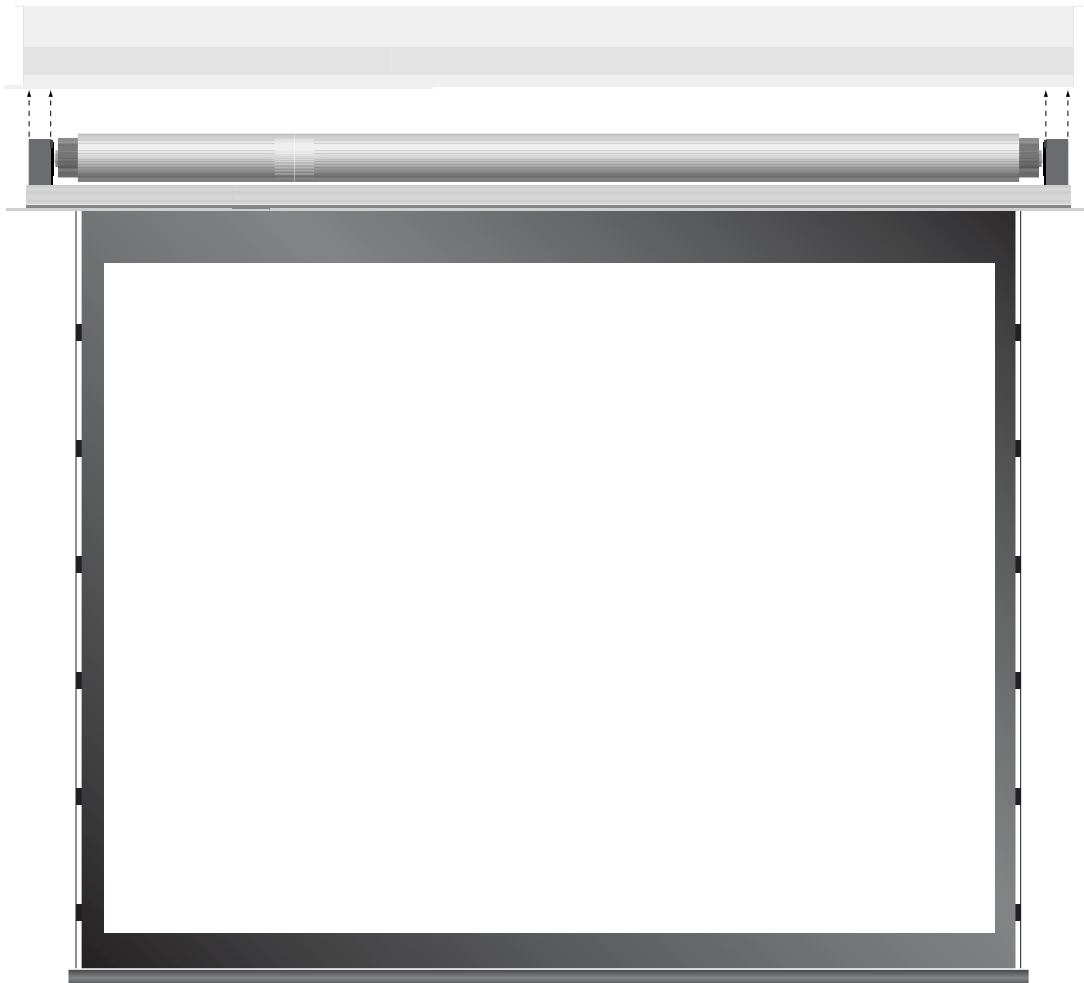

- TO THE OWNER
- INSTALLATION INSTRUCTIONS
 - OPERATING THE SCREEN
 - MAINTENANCE



Printed in U.S.A.

©2003–2011 Stewart Filmscreen Corporation

Stewart Filmscreen reserves the right to make changes to the product specified in this document.

From time to time, this document is updated. Current versions of documentation are posted on the Stewart Filmscreen website at:

www.stewartfilmscreen.com

Visionary Electriscreen

Owner's Manual

Contents

To the Owner	2
Preparing the Installation	2
Step 1. Hanging the Case	4
Step 2. Electrical Hook-up	5
Step 3. Installing the Screen Assembly Into the Case	11
Operating the Screen	12
Adjusting the Screen Extension	12
Screen Care and Cleaning	14
Troubleshooting	15
Product Warranty	17

TO THE OWNER

Congratulations on your purchase of the finest optical viewing screen available anywhere in the world!

Please take a moment to review this manual, it will help ensure you many years of trouble-free service from your new Stewart Filmscreen product.

About your Visionary Electriscreen

The Visionary Electriscreen is designed for ease of installation. The case can be installed separately during construction, and the screen assembly is then installed once the construction is completed. The Visionary features a seamless, self-finishing face-plate and drywall stops to accommodate various ceiling configurations.

PREPARING THE INSTALLATION

- ◆ **Before proceeding with the installation of this screen, be sure to read and understand all the installation and operating instructions thoroughly.**
- ◆ **All electrical wiring installations must conform to local and national codes and should be performed by qualified service personnel.**
- ◆ **There are no user-serviceable parts contained within the unit.**

Preparation

Specifications regarding the individual screen dimensions, weight, mounting type, and controls are provided by the factory when the unit is ordered.

Before beginning the installation:

- ◆ Check the specifications for the type of mounting and switch control to be used.
- ◆ Ensure that the mounting area and electrical connection are prepared. Generally the switch control mechanism is placed near the AV control system to facilitate maintenance of the controls.
- ◆ Check the size and weight of the screen to be installed so that you can plan for the number of people required for the mounting procedure. You need at least two people to mount the smaller screens; more are needed for larger, heavier screens.
- ◆ On the screen housing, note the removable Image Centerline sticker. Use the sticker to help you accurately position the screen. Be sure to remove this sticker after installation.

You will need:

- ◆ Enough ladders for the personnel supporting the screen during the mounting process
- ◆ A level
- ◆ Fasteners appropriate for the surface on which the screen is being mounted (See instructions for the type of mount for recommendations.)
- ◆ A wrench (supplied)

Note: This manual refers to “AC” to represent electrical power. Your location may use 120 V, 220 V, or other electrical power. Screen systems are manufactured using the electrical power type specified for the location. Use appropriate power sources for your location.

Unpacking

1. Remove the outer plastic covering and white wrapping paper surrounding the screen case.
2. Do not remove the wrapping paper surrounding the screen roller. You should remove it only after the unit is hung and all electrical connections have been made.

Caution

During installation, do not place the unit on an unstable cart, stand, table, or ladder. The unit may fall, causing injury to a child or adult and damage to the unit.

STEP 1. HANGING THE CASE

Professional mounting techniques should be used. Stewart Filmscreen Corporation cannot be liable for substandard or faulty installations.

Follow the instructions for mounting the case first, then install the screen assembly into the case after you make the initial electrical connection to the pigtail.

Make sure that you mount the case so that the electrical connection is on the left side (audience left).

Removing the screen assembly from the case

The unit is shipped with the screen assembly fastened inside. Prior to mounting the unit, you must remove the screen assembly from the case. Using the supplied wrench, loosen the bolts shown in Figure 1. There is a bolt inside each end of the screen slot.

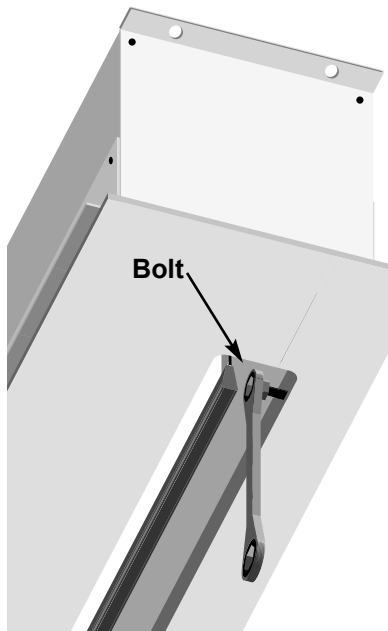

Figure 1: Bolt securing screen assembly to case

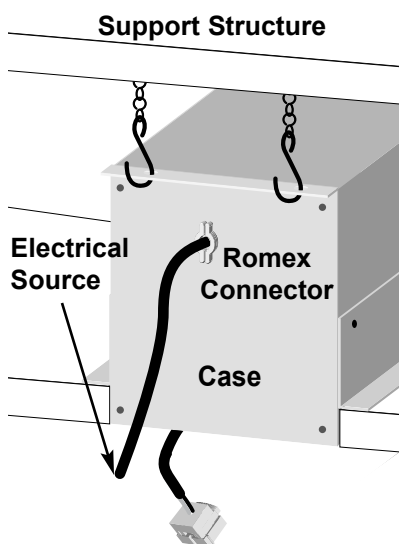

Figure 2: Mounted case

Mounting the case

Follow this procedure to mount the case. The Visionary Electriscreen can be installed into the ceiling or soffit. A false ceiling is not intended to support the weight of a Visionary Electriscreen.

The unit is usually suspended, as shown in Figure 2, but it can be secured to the ceiling using bolts or other appropriate fasteners.

If the unit is to be mounted to plaster, drywall, masonry, or other type of surface, use an appropriate fastener. (These might include toggle or molly bolts or similar fasteners.)

1. Install the case onto the support structure making sure that the bottom is flush with the finished ceiling, if any.
2. Make sure the case is level.
3. Drywall or other ceiling material may be screwed directly to the ceiling flanges on the case. Refer to Figure 2.

STEP 2. ELECTRICAL HOOK-UP

Caution

Professional techniques need to be used when making any electrical connection. A qualified electrician should perform these procedures.

Be sure to follow all standard safety procedures for installing electrical devices.

Do not disassemble or alter the configuration of the motor or the unit's electrical connections. This may cause injury to you or damage to the product.

The electrical connection should be made only to the type of power source indicated on the marking label.

The motor requires standard AC input (unless an alternate voltage has been specified). All connections are made to the electrical box on the side of the unit (audience left).

There are several switch controls available. Follow the installation procedure for the type of switch control you will install.

General suggestions for wiring:

- ◆ Soldering is recommended.
- ◆ The use of wire nuts is acceptable.

Stewart Filmscreen supplies a short electrical connection wire that is fitted with a Molex motor connector. You will connect the harness (pigtail) to the incoming AC Romex or service cord by wire nuts. Refer to Figure 3 for an illustration of the electrical connection on the side of the screen unit.

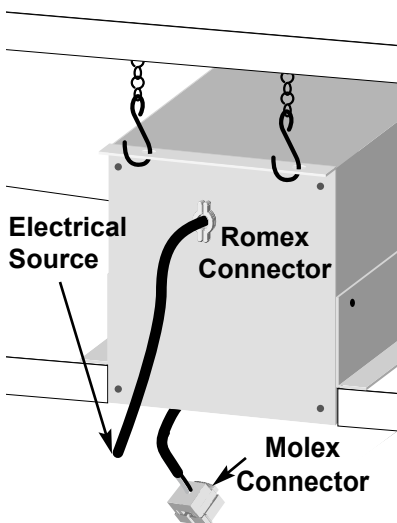

Figure 3: Electrical connection



Installing the high voltage switch control

A standard 3-position AC wall switch is supplied. The high-voltage control is connected to standard wall jack that is installed near the unit. The switch alternates directions of screen motion by means of the hot lead, using the 3-position switch.

Preparing the connection

Before making the electrical connections, you need:

- ◆ An available AC constant power source
- ◆ A 4-conductor romex or motor connector cable

Making the connections

Figure 4 illustrates the connections.

1. Connect the wall switch to the AC constant power source.
2. Connect the wall switch to the screen unit's electrical box.

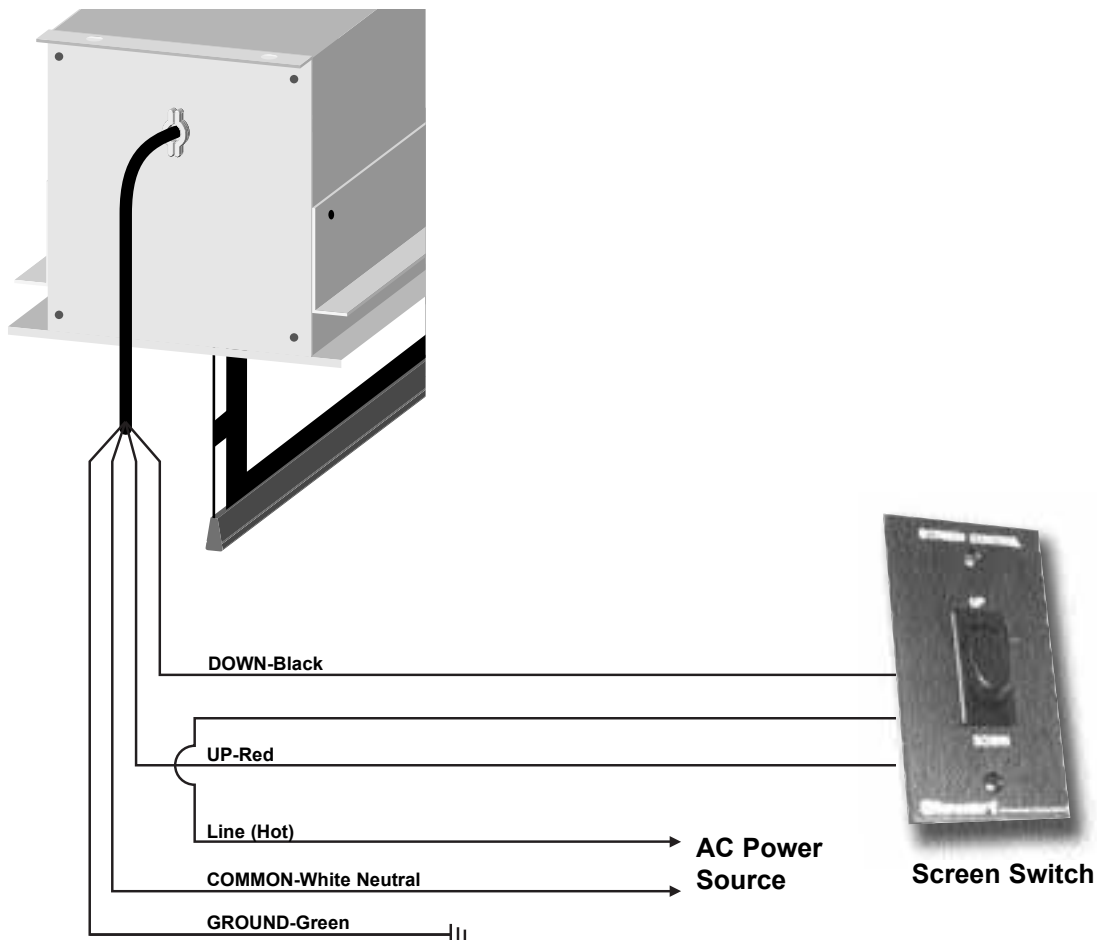

Figure 4: High voltage control wiring diagram

Installing the low-voltage 3-button switch option

The optional Stewart Filmscreen low-voltage control allows the use of low-voltage wire to connect to the supplied 3-position 24V momentary wall switch.

Preparing the connection

Before making the electrical connections, you need:

- ◆ An available AC constant power source
- ◆ A 4-conductor switch hook-up cable (4-conductor bell wire or category 5 cable is typically used for long runs)
- ◆ Cat 5, multi-conductor unshielded, or similar type electronic cable can be used to connect the 3-button switch to the LVC. The recommended wire gauge is 20 to 24 AWG. Use plenum-rated cable when required.

Making the connection

Figure 5 illustrates the connection.

1. Mount the low-voltage control box near the screen.
2. Connect the low-voltage control box to the screen by connecting the screen motor power leads to the power strip terminal block located on the circuit board of the control box.
3. Connect the low voltage control box to the AC power source by connecting the AC line voltage to the power strip terminal block located on the circuit board of the control box.
4. Connect the switch to the low-voltage control box.
5. A parallel connection to an outboard audio-visual switching network can be made at this time. (optional)

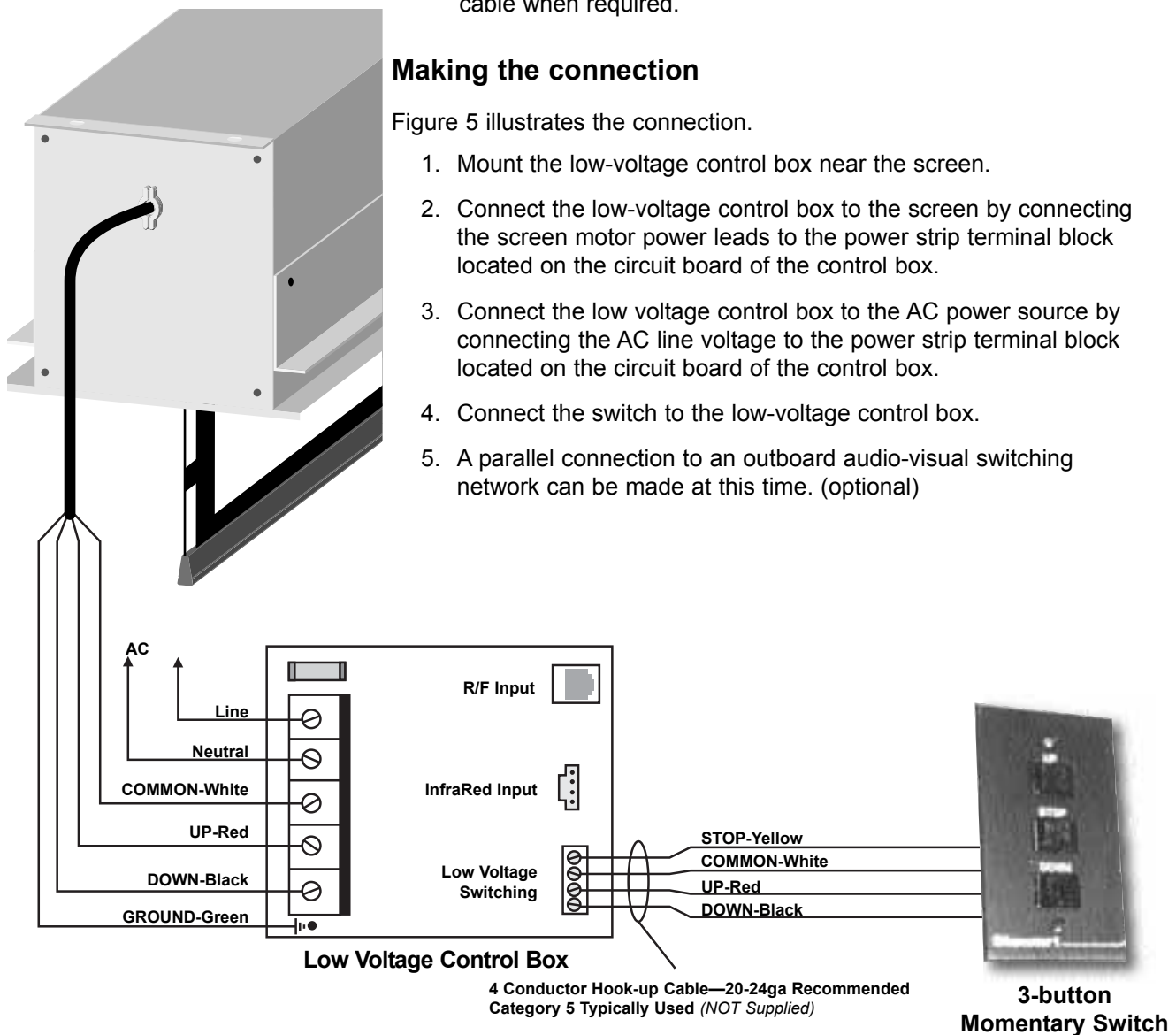

Figure 5: Low voltage 3-button switch wiring

Installing the infrared remote control option

The optional Stewart Filmscreen infrared remote control allows control of the screens from anywhere in the room.

Note: The distance between the hand-held remote control and the receiver can be up to 50 feet / 15 m. It is necessary to have uninterrupted line-of-sight between the remote and the receiver.

Preparing the connection

Refer to the previous section “Installing the low-voltage 3-button switch option.”

Making the connection

Figure 6 illustrates the connection.

1. Mount the low-voltage control box near the screen.
2. Mount the infrared (IR) eye sensor near the screen.
3. Connect the low-voltage control box to the screen by connecting the screen motor power leads to the power strip terminal block located on the circuit board of the control box.
4. Connect the IR eye sensor to the small black plug-in module located next to the switch input on the circuit board.
5. Connect the low voltage control box to the AC power source by connecting the AC line voltage to the power strip terminal block located on the circuit board of the control box.
6. Connect the switch to the low-voltage control box.
7. A parallel connection to an outboard audio-visual switching network can be made at this time. (optional)

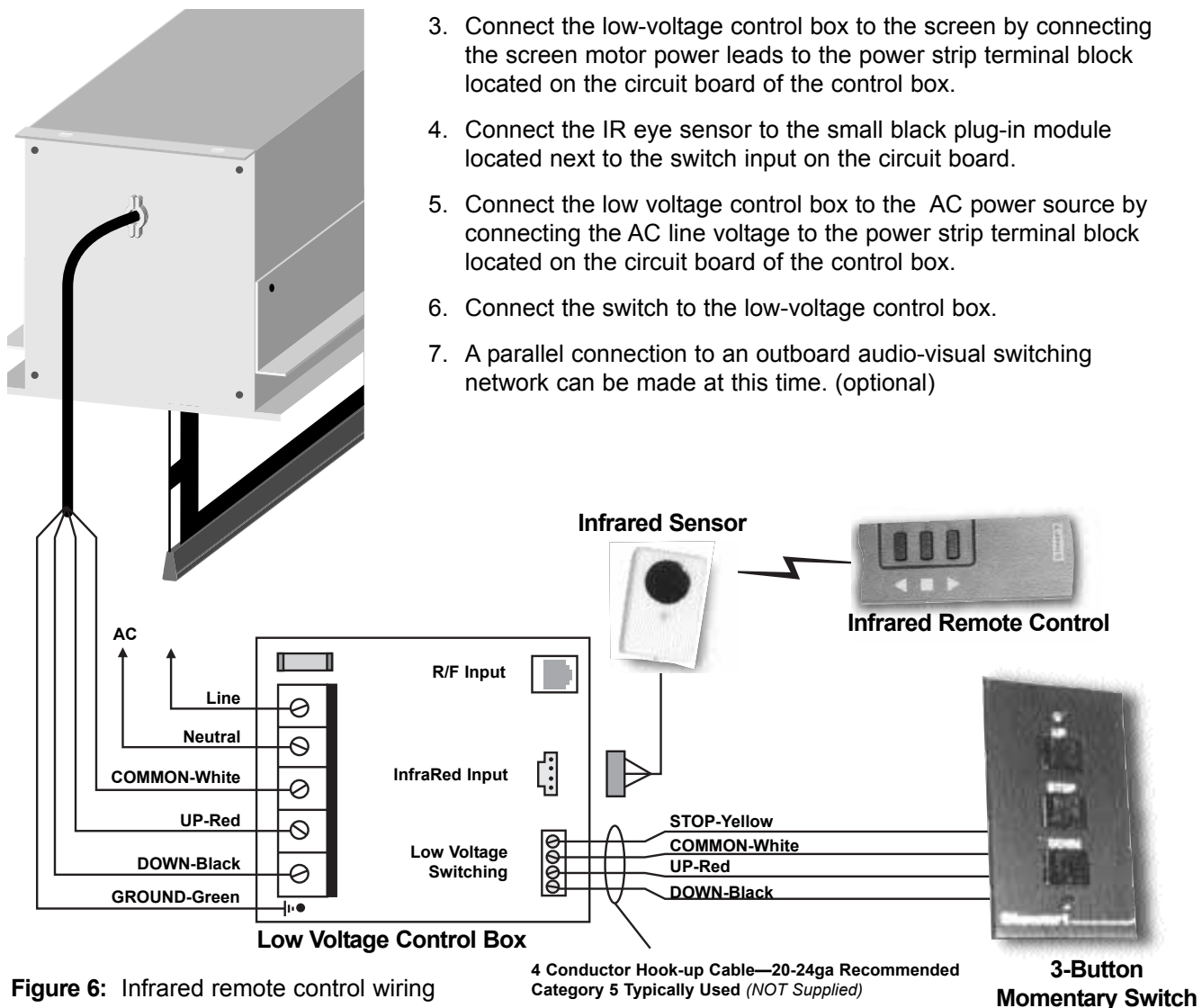

Figure 6: Infrared remote control wiring

4 Conductor Hook-up Cable—20-24ga Recommended
Category 5 Typically Used (NOT Supplied)

3-Button
Momentary Switch

Connecting the Video Interface Control System (VICS)

The 12V VICS enables up and down operation of the screen in conjunction with a projector, tuner, VCR, cable box, or switched AC outlet.

Preparing the connection

Before making the electrical connections, you need:

- ◆ An available AC constant power source
- ◆ A 4-conductor cable (14ga)

Making the connection

Figure 7 illustrates the connection.

1. Feed the cable with the pigtail back into the screen case through the Romex connector.
2. Feed one end of a length of a 4-conductor cable (14ga) through the same connector as in step 1.
3. Connect the 4-conductor cable to the pigtail inside the unit.
4. Use a screwdriver to open the VICS unit.
5. Feed the other end of the 4-conductor cable through the Romex connector on the VICS unit.
6. Connect wires to the terminal block.
7. Secure the clamp on the Romex connector.
8. Replace the cover on the VICS.
9. Plug the AC power cord of the VICS into the AC outlet.
10. Attach the 12V trigger wire to the jack in the VICS.

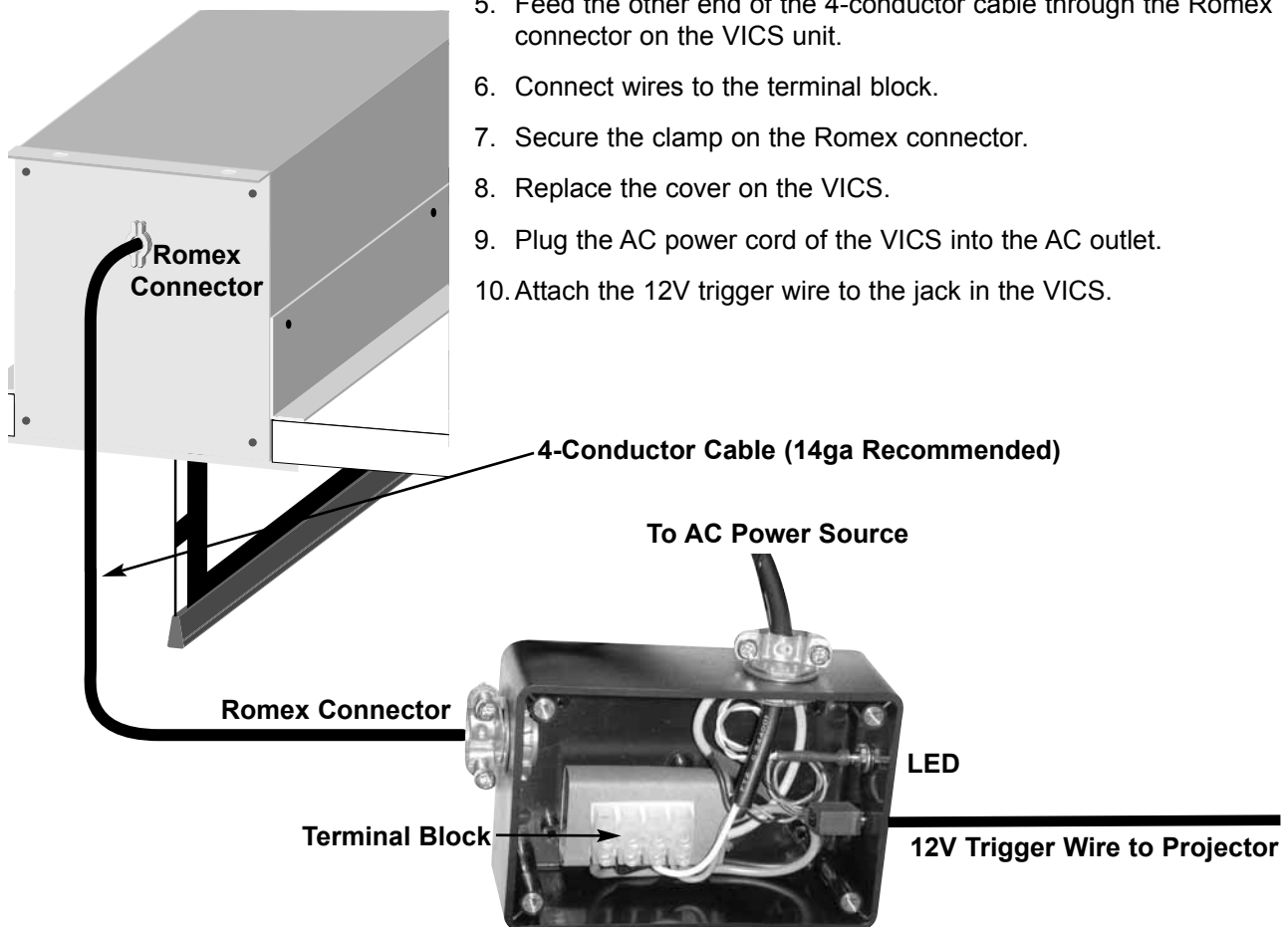

Figure 7: VICS connection

Installing the wireless remote control option

The optional Stewart Filmscreen wireless remote control allows control of the screen from anywhere in the room.

Note: The distance between the hand-held remote control and the receiver can be up to 50 feet / 15m. It is not necessary to have uninterrupted line-of-sight between the remote and the receiver, but there should be no metal objects between them. The override switch on the bottom of the receiver can be used instead of the remote control.

Preparing the connection

Before making the electrical connections, you need:

- ◆ An available AC power source

Making the connection

Figure 8 illustrates the connections.

1. Connect the 4-conductor cable to the receiver module.
2. Open the wireless remote receiver module and connect motor wires according to the labels inside.
3. Plug the receiver module into the constant AC power source.

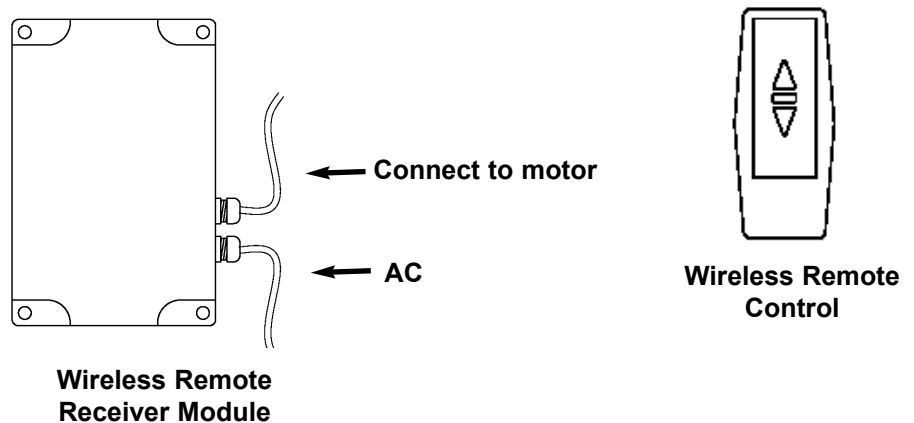

Figure 8: Wireless remote control connection

STEP 3. INSTALLING THE SCREEN ASSEMBLY INTO THE CASE

Caution

During installation of the Visionary Screen into the mounted housing, be advised that damage can occur to the screen. Perform the following actions to avoid damage:

- ◆ When lifting the screenroll assembly up into the case, make sure the screen does not come into contact with the sides of the housing.
- ◆ Notice the flange screw positions on the inside of the case and take precautionary steps to avoid hitting these with the screenroll.
- ◆ When installing the screenroll assembly make sure that the screen never contacts or strikes any objects as damage will occur as a result.

Follow this procedure to mount the screen assembly in the case. Be sure you have performed the appropriate electrical hookup first. Refer to the Caution before performing these steps.

1. Raise the screen assembly to the previously mounted case.
2. Insert the interlocking modular connector from the screen assembly to the corresponding connector in the case. Refer to Figure 9.
3. Make sure the cable and modular connectors stay inside the electrical box when the screen assembly is inserted into the case.
4. Using the wrench provided, secure the screen assembly to the case using bolts inside each end of the screen slot. As you tighten the bolts, the screen assembly/ceiling cover will move forward and lock into place on the case. Refer to Figure 1.

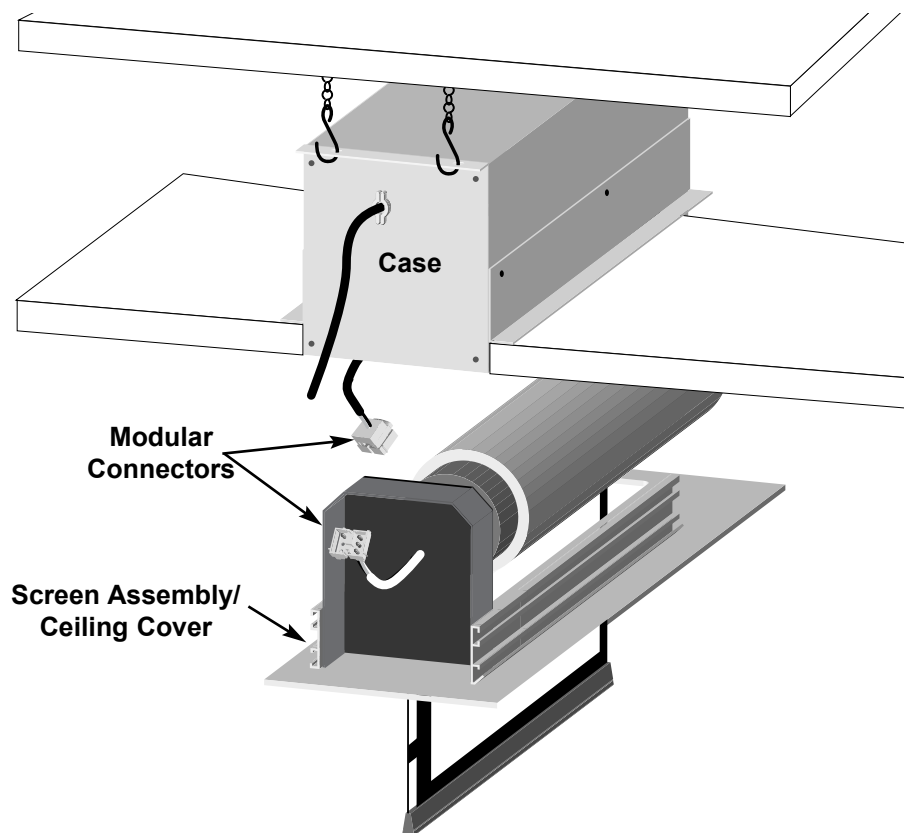

Figure 9: Installing screen assembly

OPERATING THE SCREEN

The method you use to raise and lower the screen depends on the type of switch control device you have selected.

When you lower or retract the screen, it will stop at its preset limit. If an obstacle (such as a person or furniture) gets in the path of the screen as it is lowered, you should use the switch control to stop the screen's motion; it will not automatically stop if it hits an obstacle.

The motor is designed to be used for short operations such as lowering the screen in preparation for viewing. The motor is not designed for continuous duty. If the motor operates continually for more than a few minutes, it may automatically shut off to prevent damage from overheating. If the motor occasionally needs to be run more than normal, for example during initial setup and positioning, allow time for the motor to cool down.

In general, when the screen is not in use, you should store it in the fully retracted position.

Caution

Do not operate the motor when any of the following occurs:

- ◆ The unit emits any smoke, heat, abnormal noise or unusual odor.
- ◆ The unit is damaged in some way, such as damage from a water leak.

If any of these situations occurs, call a qualified service person.

ADJUSTING THE SCREEN EXTENSION

Caution

Improper adjustment of the limit switches can cause irreparable damage to the screen itself, resulting in voiding the factory warranty.

The extension and retraction limit switches have been preset at the factory. In general, we advise you to avoid readjusting these switches.

In some cases, to enable proper alignment of the displayed image on the screen, you may need to adjust the extension of the screen. If adjustment to the extension is necessary, carefully follow these instructions.

Warning!

The screen is fully retracted when the batten is flush with the bottom of the case. Do not attempt adjustments with the yellow retraction (UP) limit switch that will further retract the screen. Incorrect adjustment of the switch will cause severe screen damage. Please consult the factory if you have any questions.

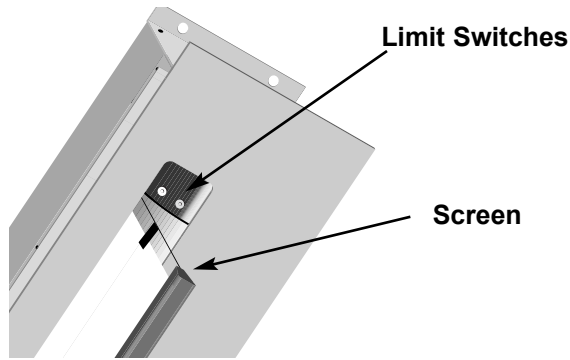

Figure 10: Underside view

Modifying the extension of the screen

You can increase the extension of the screen up to 3" (7.6 cm) past the factory preset stop, or you can decrease the extension by approximately 4–6" (10–15 cm) from the factory preset stop. Do not attempt to modify the screen extension beyond these recommended amounts.

The limit switches are located on the left side of the screen roller tube inside the case, as shown in Figure 10.

To increase the screen's fully extended (screen down) stop position:

1. Lower the screen to its current stop position.
2. Locate the white extension (down) limit switch located on the left side of the screen tube. Use a hex head or an electrician's style screwdriver (with a minimum 6-inch / 15 cm blade). Turn the switch in a counterclockwise direction. If the power is on, the screen will drop incrementally as the switch is turned.

Note: One complete turn of the switch will make approximately a 3/4" (2 cm) change in the screen's stop position.

To decrease the screen extension:

1. Lower the screen until it is extended about halfway down.
2. Locate the white extension (down) limit switch located on the left side of the screen tube. Use a hex head or an electrician's style screwdriver (with a minimum 6-inch / 15 cm blade). Turn the switch in a clockwise direction.

Note: One complete turn of the switch will make approximately a 3/4" (2 cm) change in the screen's stop position.

3. Activate the screen in the down direction until it reaches the newly reduced stop position. Repeat this procedure until the desired stop position is reached.

Once you have made the adjustment, whenever you lower the screen, it will automatically stop at the new position.

Note: It is recommended that you make a note of any changes made to the factory preset.

SCREEN CARE AND CLEANING

With reasonable care, you may expect many years of trouble-free use of your Stewart projection screen.

We encourage you to keep your screen clean. To protect your screen when it is not in use, store it in the fully retracted position.

Avoid getting any foreign material on the screen, as cleaning may prove very difficult. It may not be possible to remove scratches, paint, ink, etc.

General maintenance

The screen surface on your screen is delicate. Special attention to these instructions should be followed when cleaning.

- ◆ A draftsman-style brush may be used to lightly whisk away any loose dirt or dust particles. (This type of brush is usually available at office supply stores.) Stewart Filmscreen has an optional screen cleaning kit that contains the proper type of brush. Contact your dealer if you would like to obtain this cleaning kit.
- ◆ Particles left on the screen when it is retracted into the case may form an impression on the screen surface. Periodically wipe the back of the screen with a clean damp cloth.
- ◆ For tougher spots, use a solution of mild detergent and water. Rub lightly using a sponge. Blot with a damp sponge to absorb excess water. Residual water marks will evaporate within a few minutes. Let the screen air dry completely before retracting.

Do not use any other cleaning materials on the screen. Contact the factory if you have questions about removing difficult spots.

Replacement parts and service

No user-serviceable parts are contained within the unit. Contact your dealer or the factory if you require part replacement or service.

TROUBLESHOOTING

Refer to the following guidelines if you encounter a difficulty in the operation of your Stewart Filmscreen. Problems related to electrical or motor function may require a qualified service person or electrician.

Should you have a problem that is not addressed here, call the Stewart Filmscreen Corporation.

Problem description	Probable cause	Action to take
Screen won't operate.	No AC power available.	Check to see if the circuit breaker has switched off. Reset if needed. Check outboard switching apparatus. Check voltage availability. Contact an electrician.
Screen won't roll up or down (even though power is available).	Bad connection at switch. Polarity of VICS line may be bad.	Have an electrician or qualified service person check the connection as follows: <ul style="list-style-type: none"> • If you have a <i>high voltage control</i> switch, check switch-line connections. • If you have a <i>low voltage control</i> unit, check switch-line connections. • If you have a <i>VICS</i>, check line connections, or the mini-plugs at the screen input or projector output. Check 12V DC line for correct polarity. Contacts may be sticking—tap relay to free contacts.
Screen roller chatters when power is activated.	Can be caused by voltage drop, bad connections, or a defective switch.	Have an electrician or qualified service person check all hook-ups including all outboard wiring.
Unit hums in up mode. (Screen has already retracted.)	The screen batten is retracting too far into the case. Failure to correct can damage motor and screen. Do not use the unit until this problem is resolved.	Have a qualified service person adjust the yellow UP limit switch. Turn the adjusting screw clockwise.
Screen drops when up direction is activated (grinding noise occurs).	Drop in voltage.	Screen motor requires full voltage. Have an electrician or qualified service person check available voltage.

Problem description	Probable cause	Action to take
Screen continues past bottom stop position.	White limit switch is out of adjustment.	Readjust the white DOWN limit switch. See pp. 12-13 of this manual.
Batten retracts too far into case.	Yellow limit switch out of adjustment. Failure to correct can damage motor and screen. Do not use the unit until this problem is resolved.	Have a qualified service person readjust the yellow UP limit switch. See pp. 12-13 of this manual.
During operation, there is a repeated thumping or clicking sound.	Motor cable or connectors are out of position in the case and interfering with the screenroll.	Remove screenroll assembly and reposition cable and connectors so that they remain within the electrical box when the screenroll assembly is fitted back into the case. See p. 11.
<p>Motor shuts off. Motor has been in use for more than 2 minutes.</p> <p>-----</p> <p>Any controller (e.g., STI, LVC, etc.) fails to operate motor.</p>	Motor is designed for short operations (lowering and retracting), not continuous duty. Longer operation, such as during setup and positioning, causes the motor to overheat and shut off.	Allow the motor to cool down. Complete cooling can take an hour or more. Heat gain is cumulative and takes time to dissipate. If motor use is initiated before it has cooled completely, the motor will shut down again when it reaches maximum temperature.
Dirt, finger prints, marks, etc. on screen surface.	Improper handling of screen.	Brush off or use a mild detergent solution with clean rag or cotton swab.
Indentations appear on screen surface.	Debris or particles adhering to screen due to static cling.	Check back of screen; gently brush debris away by hand.

PRODUCT WARRANTY

LIMITED ONE (1) YEAR WARRANTY ON STEWART FILMSCREEN CORP PROJECTION SCREENS SYSTEM

STEWART FILMSCREEN CORPORATION (Stewart) warrants its screens to the original purchaser only, to be free from defects in materials and workmanship for a period of one (1) year from the date of purchase by the original purchaser or eighteen (18) months from date of manufacture, as defined in the serial number, provided they are properly operated and maintained according to Stewart instructions and are not damaged due to improper handling or treatment after shipment from the factory.

This warranty does not apply to equipment showing evidence of misuse, abuse, or accidental damage, including neglect caused by improper installation (i.e. proximity to hot lights, exposure to extreme heat or cold, exposure to excessive humidity, etc.) as well as product that have been tampered with or repaired by any person or third party installation, other than authorized Stewart personnel.

Stewart's sole obligation under this warranty shall be to repair or to replace (at Stewart's sole discretion) the defective part of the merchandise. This warranty expressly does not cover any costs of removal, installation, framing, or other costs incident to replacing the screen or returning it to Stewart. Returns for service should be made to your Stewart dealer. If it is necessary for the dealer to return the screen or part to Stewart, transportation (freight) expenses to and from Stewart are payable by the purchaser and Stewart is not responsible for damage in shipment. To protect yourself against damage or loss in transit, insure the product and prepay all transportation expenses.

This warranty is in lieu of all other warranties, expressed or implied, including warranties as to fitness for use and merchantability. Any implied warranties of fitness for use, or merchantability, that may be mandated by statute or rule of law are limited to the one (1) year warranty period. This warranty gives you specific legal rights, and you may also have other rights which vary from state-to-state. In no event will Stewart be liable for sums in excess of the purchase price of the product. No liability is assumed by Stewart for expenses or damages resulting from interruption in operation of equipment, or for incidental, direct, or consequential damages of any nature.

In the event that there is a defect in materials or workmanship of a Stewart Screen, you may contact our Customer Service Department at 1161 W Sepulveda Blvd, Torrance, California 90502-2797 (310-784-5300) Toll free (800-762-4999).

IMPORTANT: This warranty shall not be valid and Stewart shall not be bound by this warranty if the product is not operated and maintained in accordance with Stewart's written instructions.

Stewart Filmscreen Corporation shall not be liable for any and all consequential damage(s) occasioned by the breach of any written or implied warranty pertaining to the sale in excess of the purchase price of the product sold.

Printed in USA. Rev. 12/14/10



800.762.4999 • 310.784.5300 • Fax: 310.326.870

www.stewartfilmscreen.com

February 2011
Printed in U.S.A.
©2003–2011 Stewart Filmscreen Corporation