

# ScreenWall ElectriMask

OWNER'S MANUAL



To the Owner  
Installation Instructions  
Operating the Screen  
Maintenance

EMSN-1005

**TO THE INSTALLER: BE SURE TO LEAVE THIS MANUAL WITH THE OWNER.**



Printed in U.S.A.

©2001-2005 Stewart Filmscreen Corporation

Stewart Filmscreen reserves the right to make changes to the product specified in this document.

From time to time, this document is updated. Current versions of documentation are posted on the Stewart Filmscreen website at [www.stewartfilm.com](http://www.stewartfilm.com).

# ScreenWall ElectriMask

---

## O W N E R ' S M A N U A L

### **Contents**

---

To the Owner .....	2
Preparing the Installation .....	3
Step 1. Mounting the Frame .....	4
Step 2. Electrical Hook-up .....	9
Step 3. Hanging the Frame on the Wall .....	15
Operating the Mask .....	16
Adjusting the Mask Extension .....	16
Screen Care and Cleaning .....	18
Troubleshooting .....	19

Congratulations on your purchase of the finest optical viewing screen available anywhere in the world!

Please take a moment to review this manual, it will help ensure you many years of trouble-free service from your new Stewart Filmscreen product.

## **About your ScreenWall ElectriMask**

---

Your ScreenWall ElectriMask system is designed to integrate with the latest multi-format video projectors, which are capable of variable sizes and aspect ratios for viewing standard broadcast television and the wide format seen in commercial theaters (“letterbox”). The term aspect ratio refers to the format (width to height) in which your video sources are produced.

Your screen is equipped with a masking system to achieve different aspect ratios, for example:

- ◆ 1.85:1 screen with vertical masking
- ◆ 1.33:1 screen with horizontal masking

**Figure 1:** Vertical and horizontal masking systems

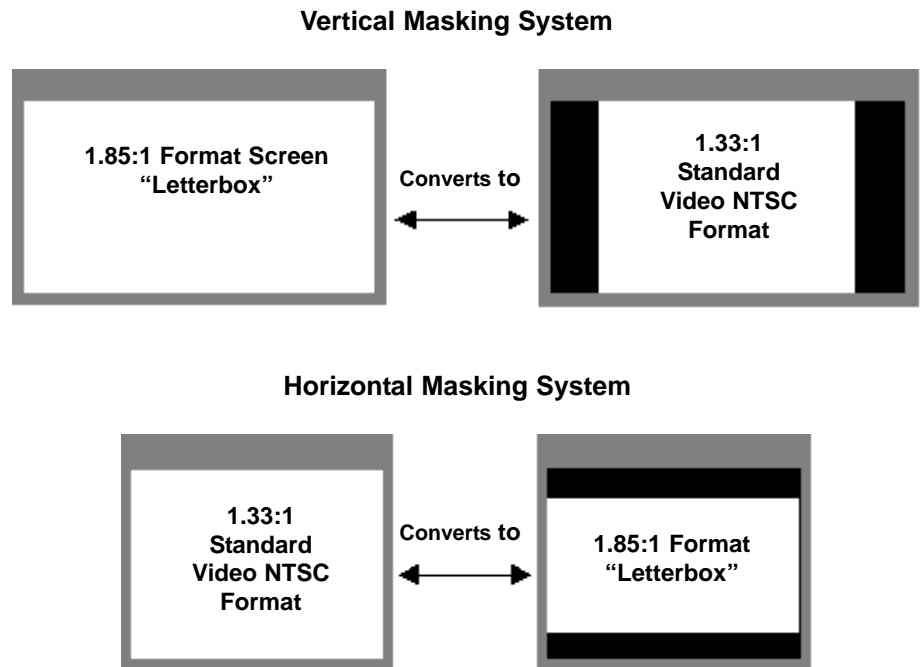

**Note:** This manual refers to “AC” to represent electrical power. Your location may use 120 V, 220 V, or other electrical power. Screen systems are manufactured using the electrical power type specified for the location. Use appropriate power sources for your location.

---

## PREPARING THE INSTALLATION

---

- ◆ **Before proceeding with the installation of this screen, take time to thoroughly read and understand these installation and operation instructions.**
- ◆ **All electrical wiring installations must conform to local and national codes and should be performed by qualified service personnel.**
- ◆ **There are no user-serviceable parts contained within the unit.**

---

### Preparation

Specifications regarding the individual screen dimensions, weight, mounting type, and controls are provided by the factory when the unit is ordered. Before beginning the installation:

- ◆ Check the specifications for the type of mounting and switch control to be used.
- ◆ Prepare the wall for electrical access to the motor(s) (audience left).
- ◆ Make sure there is a clean surface on which to unroll the screen.
- ◆ Check the size and weight of the screen to be installed so that you can plan for the number of people required for the mounting procedure. You need at least two people to mount the smaller screens; more are needed for larger, heavier screens.

You will need:

- ◆ Enough ladders for the personnel supporting the screen during the mounting process
- ◆ A level
- ◆ Fasteners appropriate for the surface on which the screen is being mounted (See instructions for the type of mount for recommendations.)
- ◆ Phillips screwdriver
- ◆ 5/8" (1.6) cm hex head screwdriver or Allen wrench

---

### Caution

**During installation, do not place the unit on an unstable cart, stand, table, or ladder. The unit may fall, causing injury to a child or adult and damage to the unit.**

---

### Unpacking

Remove the outer plastic covering and white wrapping paper surrounding the frame unit, if any. Do not remove the screen from the cardboard shipping tube until instructed to do so.

---

## STEP 1. MOUNTING THE FRAME

---

**Professional mounting techniques should be used. Stewart Filmscreen Corporation cannot be liable for substandard or faulty installations.**

**Note:** Your screen may have a vertical mask with a roller at the top only, or it may have a horizontal mask with a roller at the top and bottom. Instructions in this section apply to both types.

### **Assembling the frame**

---

Work in a clean area, making certain installers have clean hands and clothes. Assemble the frame on the floor.

1. Connect the four pieces by matching the colored, numbered dots on the ends of the frame pieces. See Figure 2.
2. Secure with the supplied 1/2" (1.3 cm) Phillips pan head bolts.
3. Bolt wall brackets to the frame using the supplied 5/8" (1.6 cm) hex head bolts. See Figure 3. Depending on the size of the screen, the number of wall brackets may vary.

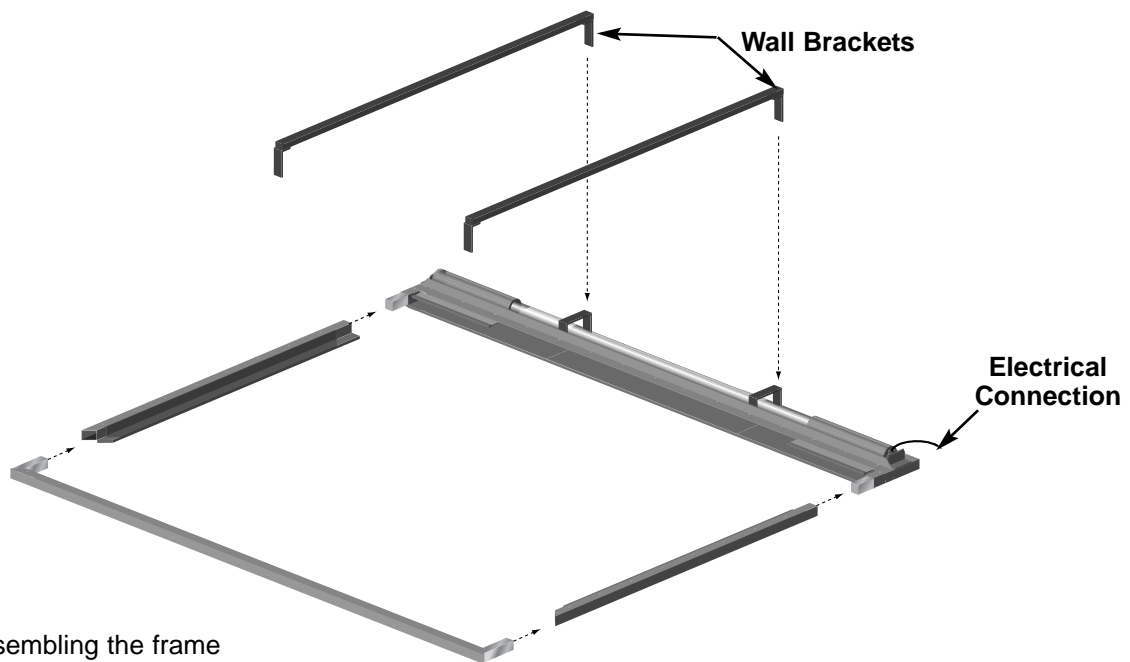

**Figure 2:** Assembling the frame

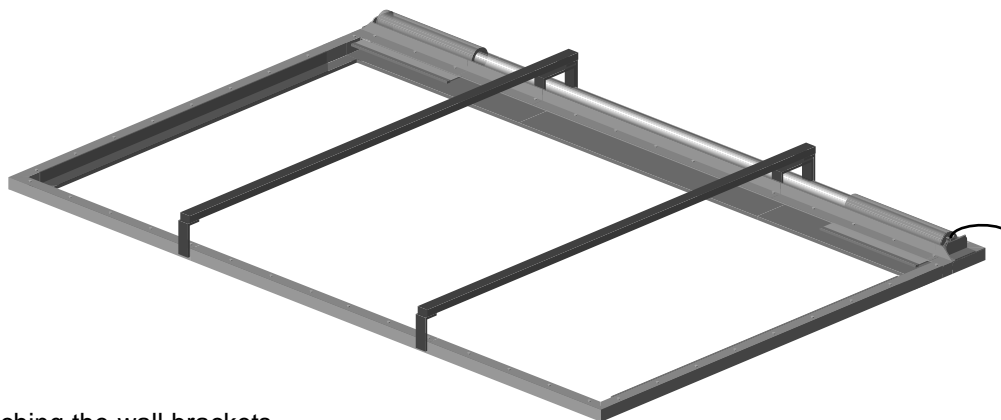

**Figure 3:** Attaching the wall brackets

---

## Positioning the frame and wall brackets

---

To accurately position the frame, you must temporarily attach the wall brackets to the frame, and then position the frame on the wall.

1. Without the screen fabric attached, position the frame and brackets on the wall.
2. Make sure the unit is level and plumb. (You may need to use shims between the brackets and the wall to achieve vertical plumb).
3. Mark the position of the bracket holes on the wall. See Figure 4.
4. Remove the brackets from the frame and attach them to the wall using the appropriate fasteners (hex lag screws, wall anchors, molly bolts, wood carriage screws, etc.). See Figure 5.

**Note:** Later, when the screen fabric is attached to the frame (next section), you will re-attach the frame to the brackets on the wall.

### Caution

**If the unit is not mounted so that it is level and plumb, horizontal masking panels may jam on retraction.**

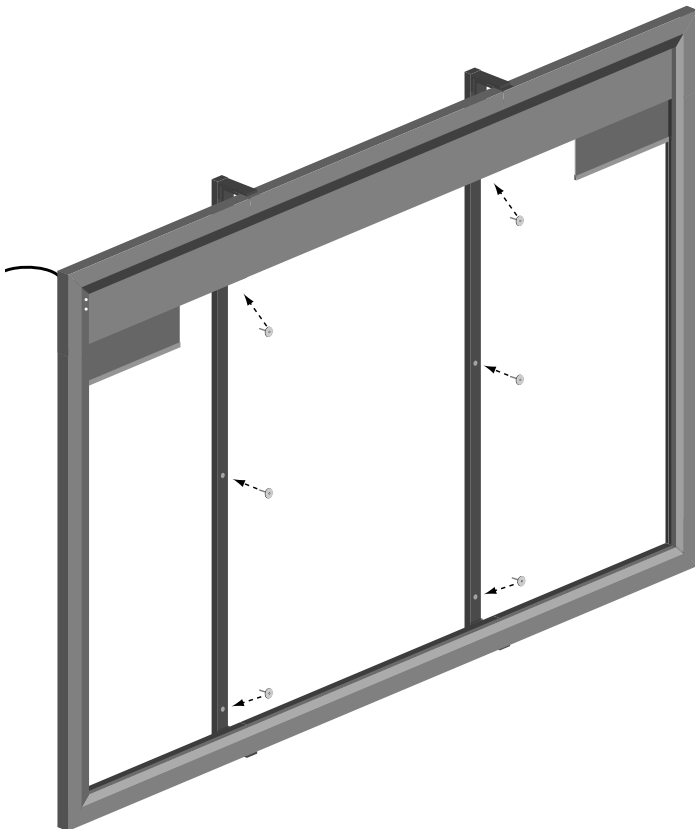

**Figure 4:** Measuring for the wall brackets

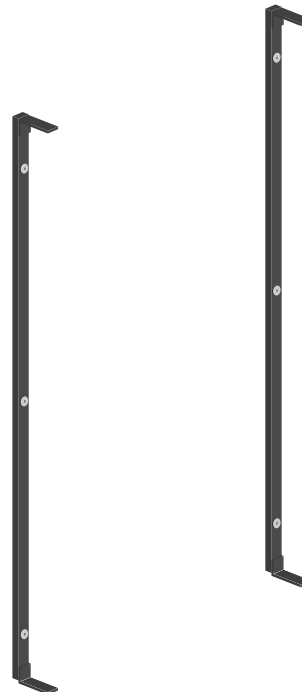

**Figure 5:** Mounted wall brackets

---

## **Unpacking and unrolling the screen**

---

The viewing side of the projection screen is rolled to the inside to protect the optical coating. The screen is rolled lengthwise.

1. Remove the screen from the cardboard shipping tube.
2. On a clean floor, unroll screen viewing side up.
3. Allow the paper to unroll between screen back and the floor. (This will keep the screen clean.) See Figure 6.

### **Caution**

- ◆ **Be careful not to touch or scratch the image surface with fingernails.**
- ◆ **Do not use any tools to fasten the screen to the frame.**
- ◆ **Do not fold or crease the screen.**

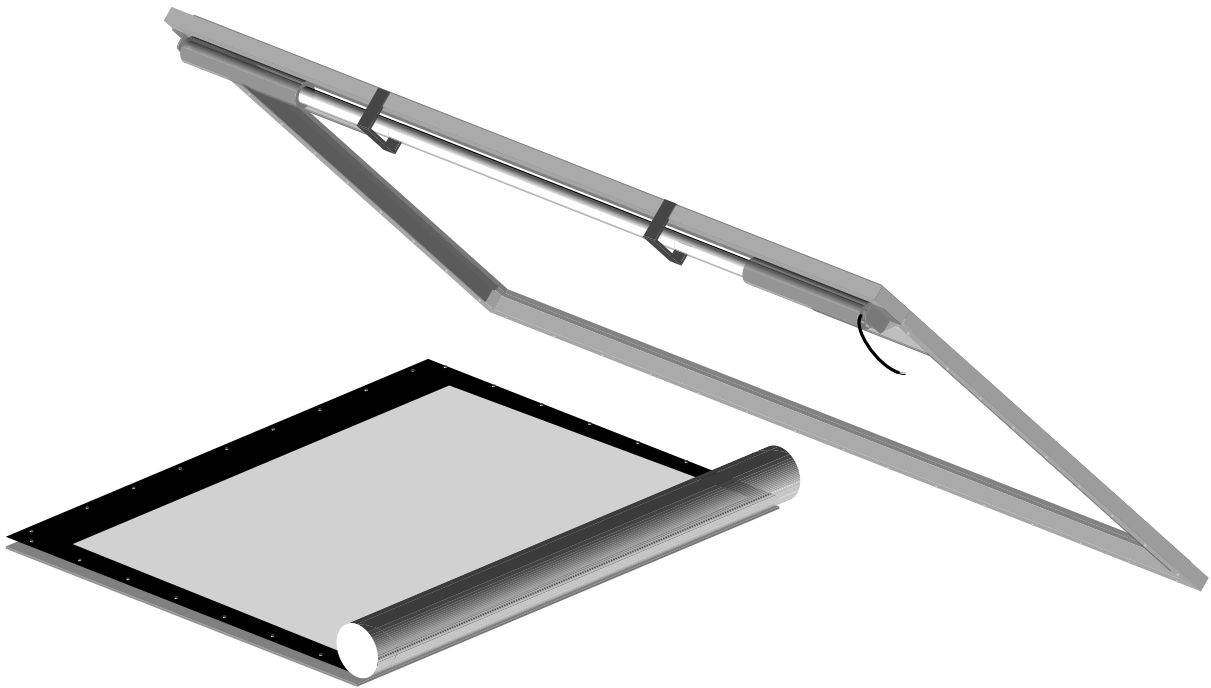

**Figure 6:** Unrolling the screen

---

### Attaching the screen to frame

---

1. Place the frame over the screen.
2. While lifting the frame with one hand, snap the screen into the frame. Gently allow the screen to stretch onto the snaps. **Do not** jerk the material, as it can rip. See Figure 7. Attach the snaps on the top corners and top horizontal first, then lift the frame to a vertical position to finish attaching the rest of the snaps.

#### Caution

**Do not use any tools to fasten the screen to the frame.**

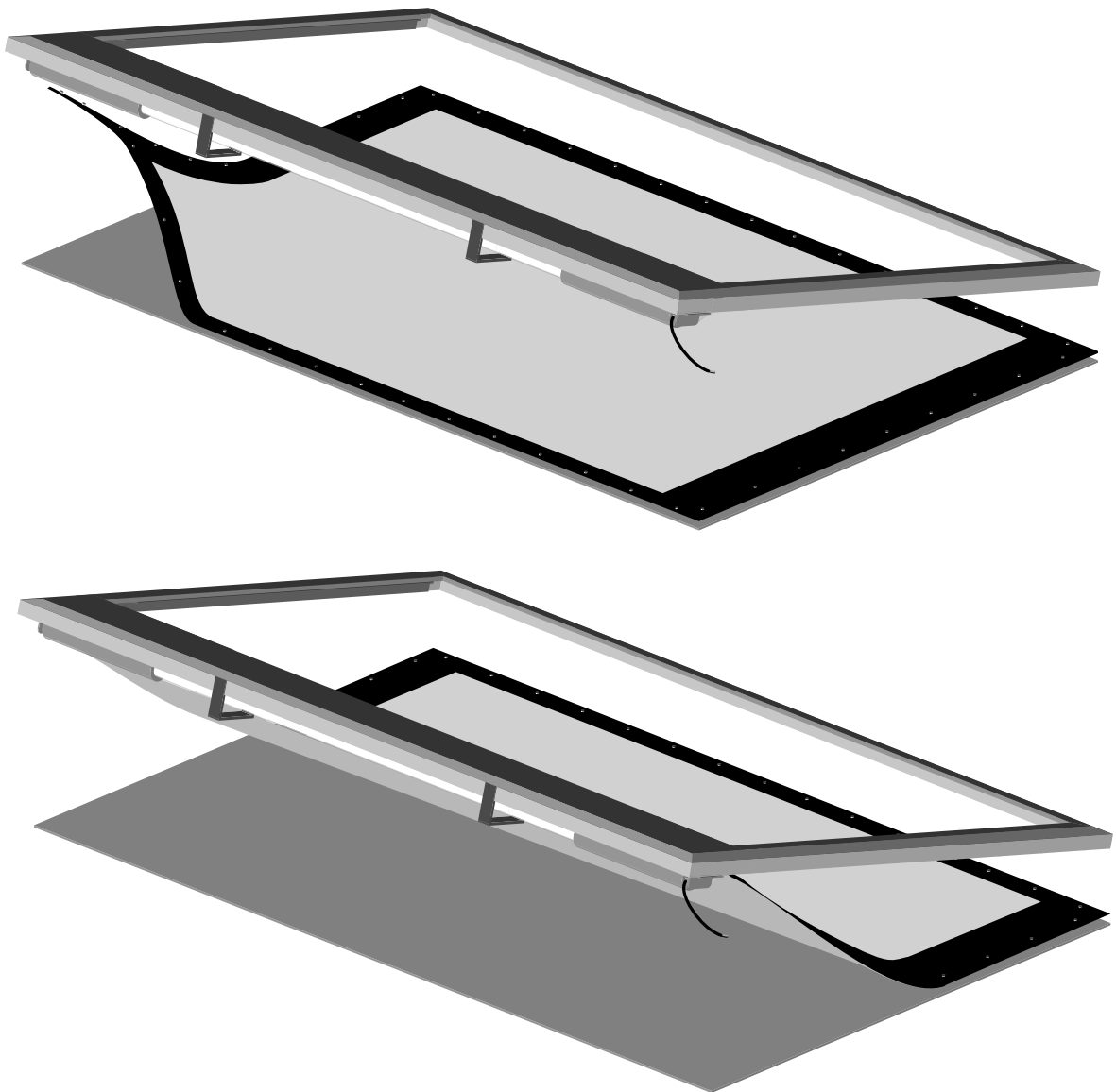

**Figure 7:** Snapping screen onto frame

---

## Connecting the spring tension cable—horizontal mask units only

---

On a system with a horizontal mask, you must fasten the lower panel's spring tension cable.

1. Locate the spring tension cables on either side of the unit.
2. Connect the baby eye snap to the eyelet on the lower bottom of the unit. See Figure 8. You will need to pull the cable slightly (about 10 lbs. / 4.5 kg of tension).
3. Repeat for the other side.

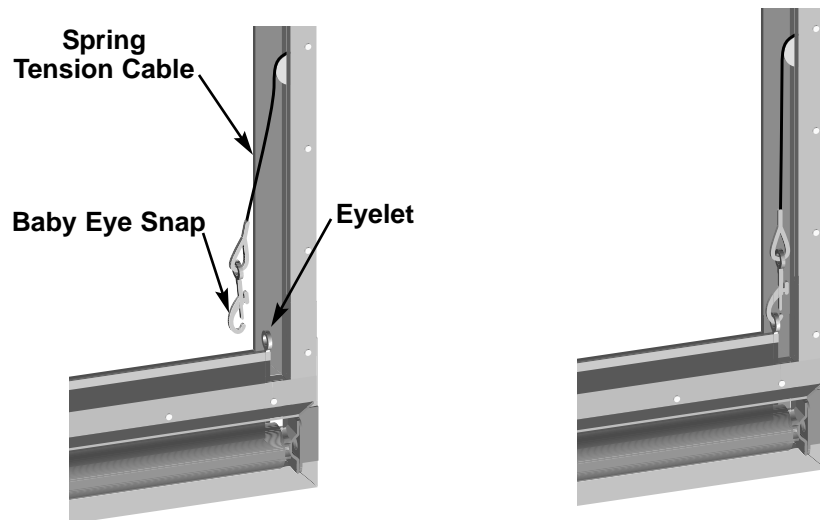

**Figure 8:** Connecting the spring tension cable

---

## STEP 2. ELECTRICAL HOOK-UP

---

### **Caution**

**Professional techniques should be used when making any electrical connection. A qualified electrician should perform these procedures.**

**Be sure to follow all standard safety procedures for installing electrical devices.**

**Do not disassemble or alter the configuration of the motor or the unit's electrical connections. This may cause injury to you or damage to the product.**

**The electrical connection should be made only to the type of power source indicated on the marking label.**

**Electrical hook-up is required for each mask roller motor. The vertical masking systems have one roller motor at the top. Horizontal masking systems have a roller motor at the top and one at the bottom.**

A motor requires standard AC power (unless an alternate voltage has been specified). All connections are made to the motor cables on the side of the unit (audience left).

There are several kinds of switch controls available. Follow the installation procedure for the type of switch control you will install.

General suggestions for wiring:

- ◆ Soldering is recommended.
- ◆ The use of wire nuts is acceptable.

---

## Installing the high voltage switch control (standard)

A standard 3-position wall switch is supplied. The high-voltage control is connected to the electrical source. It alternates directions of mask motion by means of the hot lead, using the 3-position switch.

### Preparing the connection

Before making the electrical connections, you need:

- ◆ An available AC constant power source
- ◆ A 4-conductor romex or motor connector cable

### Making the connections

Figure 9 illustrates the connections.

1. Connect the wall switch to the AC constant power source.
2. Connect the wall switch to the mask unit's electrical cable.

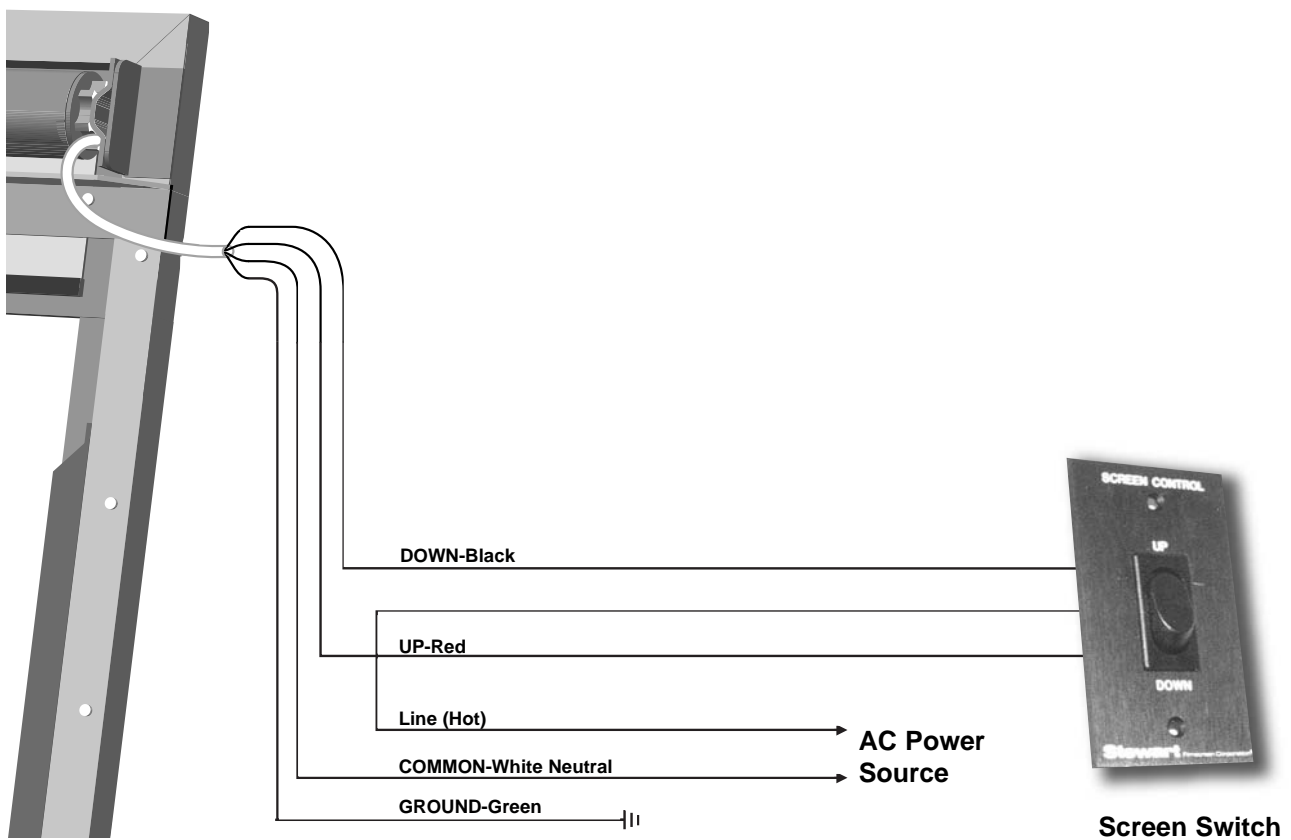

**Figure 9:** High voltage control wiring diagram

## Installing the low-voltage 3-button switch option

The optional Stewart Filmscreen low-voltage control allows the use of low-voltage wire to connect to the supplied 3-position 24V momentary wall switch.

### Preparing the connection

Before making the electrical connections, you need:

- ◆ An available AC constant power source
- ◆ A 4-conductor switch hook-up cable (4-conductor bell wire or category 5 cable is typically used for long runs)
- ◆ A 4-conductor high-voltage hook-up cable, if the control is to be mounted at a location away from the frame
- ◆ Cat 5, multi-conductor unshielded, or similar type electronic cable can be used to connect the 3-button switch to the LVC. The recommended wire gauge is 20 to 24 AWG. Use plenum-rated cable when required.

### Making the connection

Figure 10 illustrates the connections.

1. Mount the low-voltage control box near the mask.
2. Connect the low-voltage control box to the mask by connecting the mask motor power leads to the power strip terminal block located on the circuit board of the control box.
3. Connect the low voltage control box to the AC power source by connecting the AC line voltage to the power strip terminal block located on the circuit board of the control box.
4. Connect the switch to the low-voltage control box.
5. A parallel connection to an outboard audio-visual switching network can be made at this time. (optional) Use only momentary switches for this option.

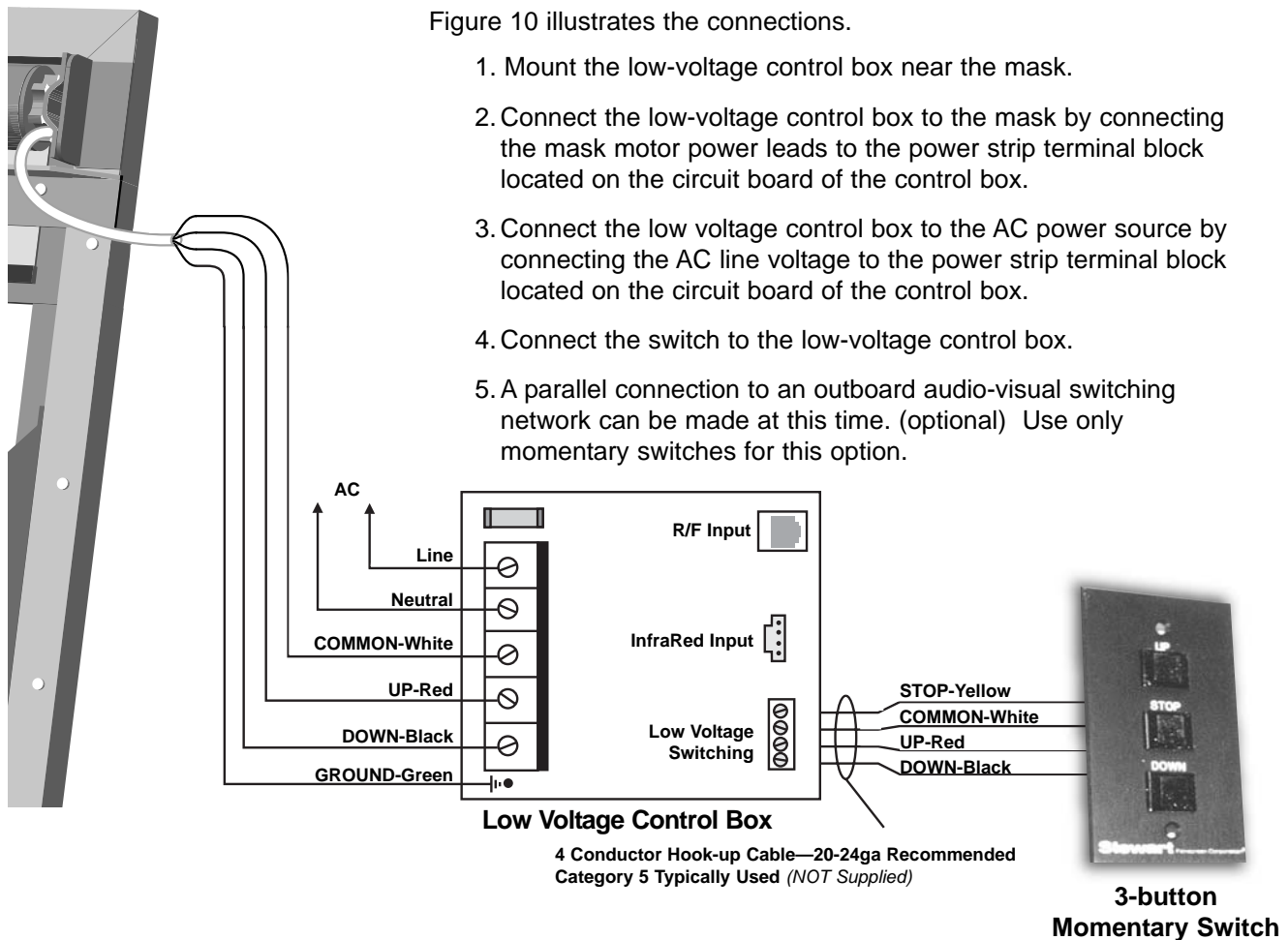

**Figure 10:** Low voltage 3-button switch wiring

## Installing the infrared remote control option

The optional Stewart Filmscreen infrared remote control allows control of the screens from anywhere in the room.

**Note:** The distance between the hand-held remote control and the receiver can be up to 50 feet / 15 m. It is necessary to have uninterrupted line-of-sight between the remote and the receiver.

### Preparing the connection

Refer to the previous section “Installing the low-voltage 3-button switch option.”

### Making the connection

Figure 11 illustrates the connections.

1. Mount the low-voltage control box near the mask.
2. Mount the infrared (IR) eye sensor near the mask.
3. Connect the low-voltage control box to the mask by connecting the mask motor power leads to the power strip terminal block located on the circuit board of the control box.
4. Connect the IR eye sensor to the small black plug-in module located next to the switch input on the circuit board.
5. Connect the low voltage control box to the AC power source by connecting the AC line voltage to the power strip terminal block located on the circuit board of the control box.
6. Connect the switch to the low-voltage control box.

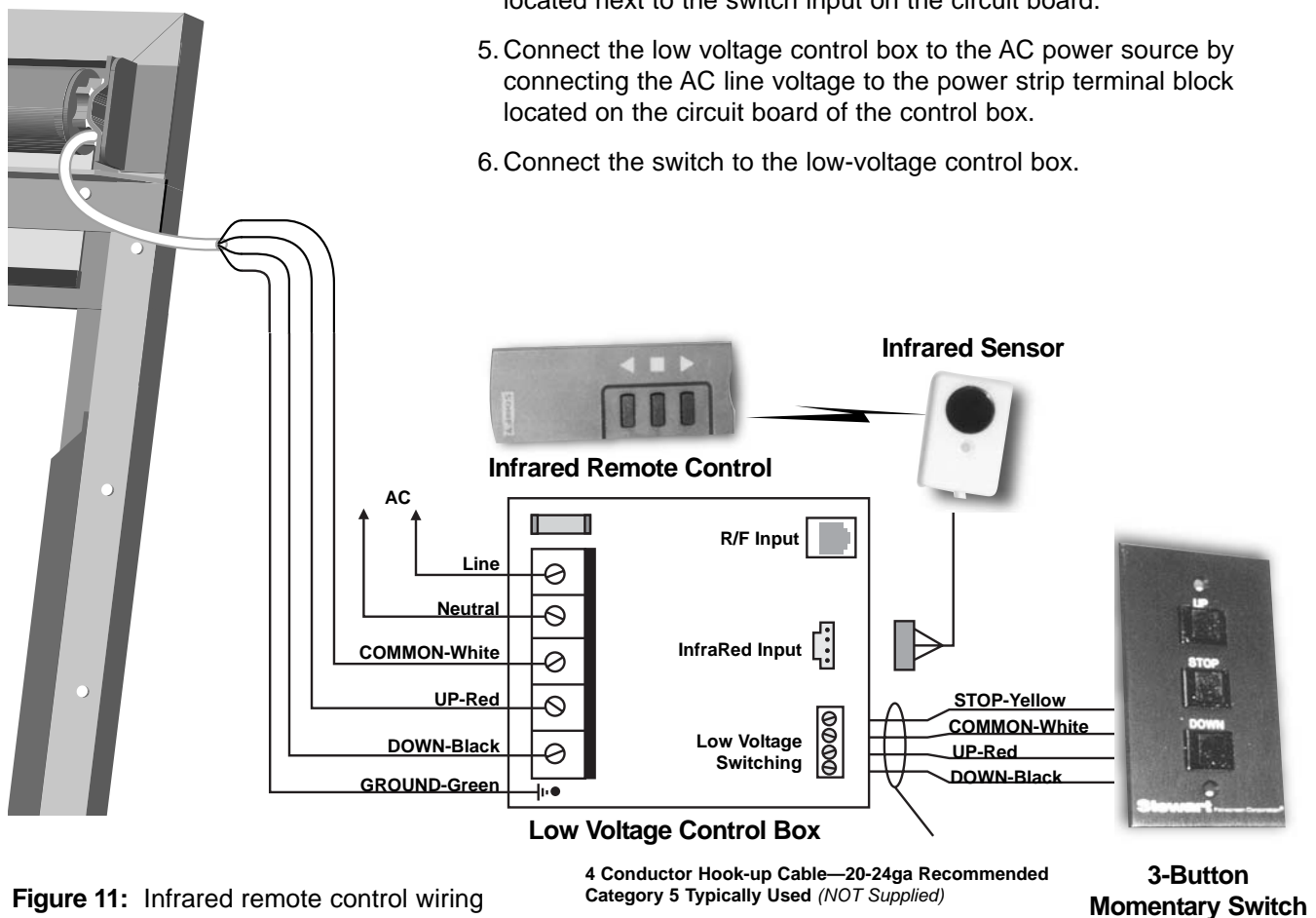

## Installing the Multi-Channel Infrared Remote control option

The optional Stewart Filmscreen Multi-Channel Infrared Remote control allows control of the screens from anywhere in the room.

**Note:** The distance between the hand-held remote control and the receiver can be up to 50 feet / 15 m. It is necessary to have uninterrupted line-of-sight between the remote and the receiver.

### Preparing the connection

Before making the electrical connections, you need:

- ◆ An available AC constant power source
- ◆ A 4-conductor switch hook-up cable (4-conductor bell wire or category 5 cable is typically used for long runs)
- ◆ Wire nuts

### Making the connection

Figure 12 illustrates the connections.

**Note:** The IR Channel Selection Switches must be set at different channels. The factory sets them at 1 and 2.

1. Mount each Multi-Channel Infrared Control box near the screen.
2. Mount each infrared (IR) eye sensor near the screen.
3. Use wire nuts to connect the screen motor power leads to the MCIR unit leads.
4. Connect each IR eye sensor to the plug-in module on the board.
5. Connect the MCIR boards to the AC power source by connecting the AC line voltage to the black and white wires on the board.

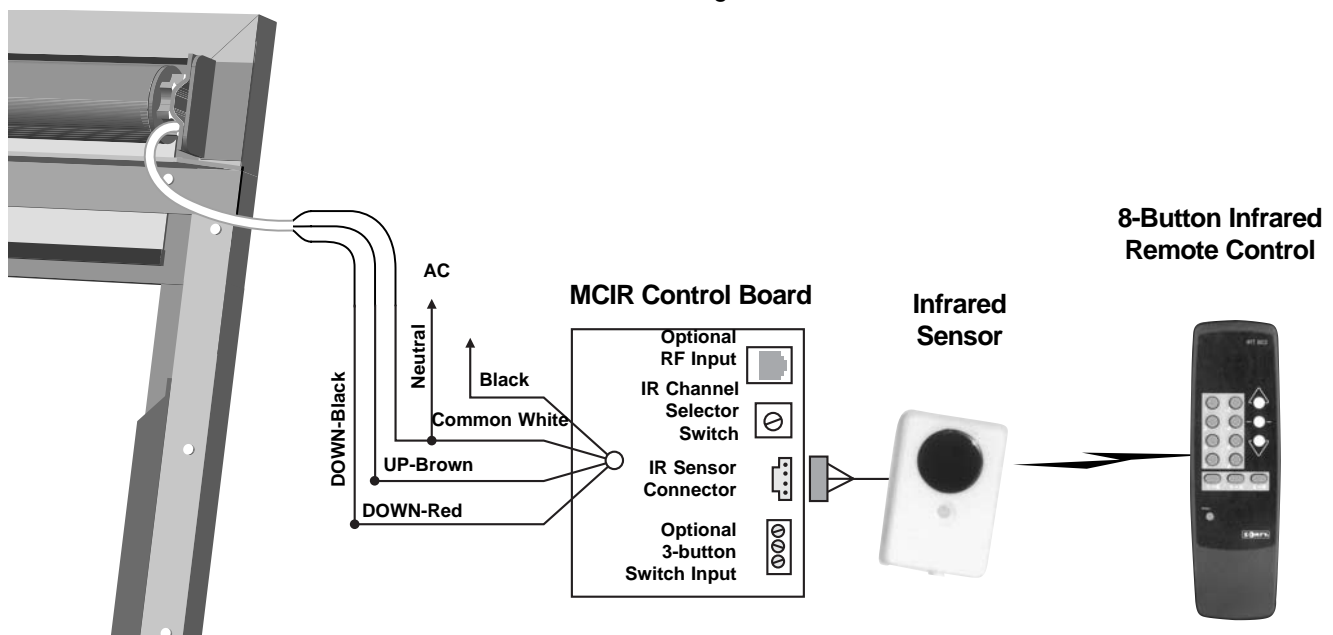

**Figure 12:** MCIR wiring

---

## **Connecting the Video Interface Control System (VICS)**

**Note:** The VICS option should not be used for the horizontal masking system.

The 12V VICS enables up and down operation of the mask in conjunction with a projector, tuner, VCR, cable box, or switched AC outlet.

### **Preparing the connection**

Before making the electrical connections, you need:

- ◆ An available AC constant power source
- ◆ A 4-conductor cable (14ga)

### **Making the connection**

Figure 13 illustrates the connections.

1. Use a screwdriver to open the VICS unit.
2. Feed the other end of the 4-conductor cable through the romex connector on the VICS unit.
3. Connect wires to the terminal block.
4. Secure the clamp on the romex connector.
5. Replace the cover on the VICS. For horizontal masking panels, connect the black motor lead to the black terminal block and the red motor lead to the red terminal block. For vertical masking panels, connect the red motor lead to the black terminal block and the black motor lead to the red terminal block.
6. Plug the AC power cord of the VICS into the AC outlet.
7. Attach the 12V trigger wire to the jack in the VICS.

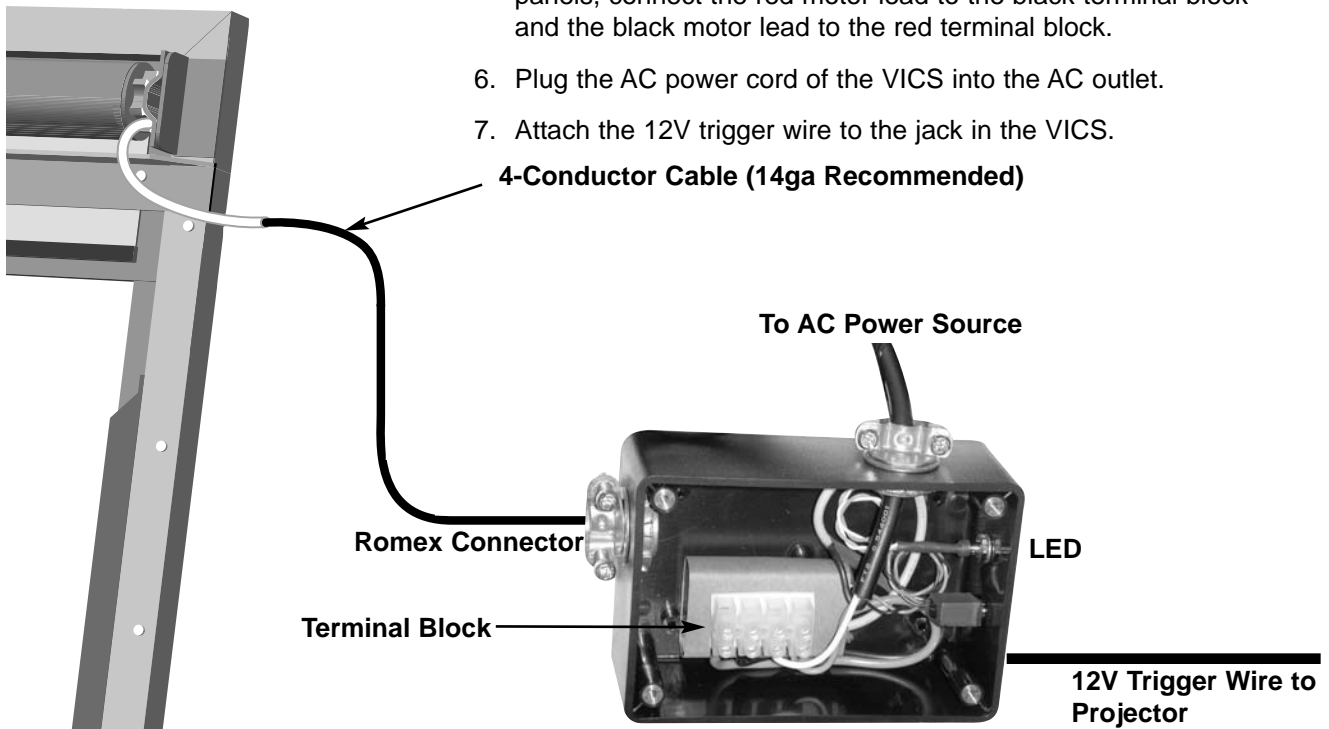

**Figure 13:** VICS connection

---

## STEP 3. HANGING THE FRAME ON THE WALL

---

Attach the ScreenWall ElectriMask to the previously mounted wall brackets using the 5/8" / 1.6 cm hex head bolts.

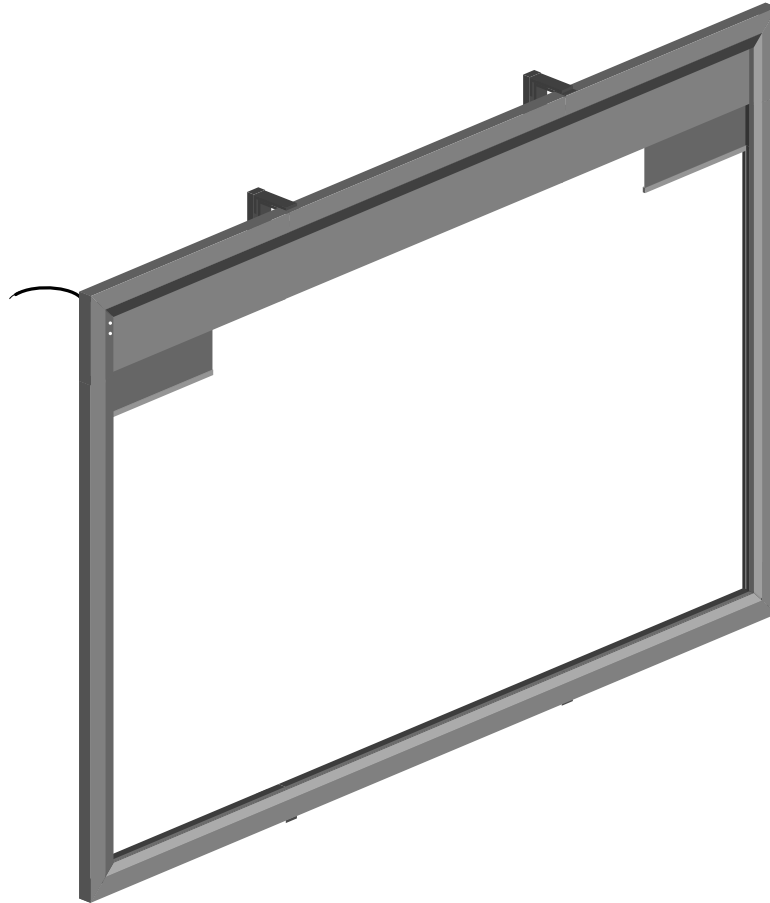

**Figure 14:** Hanging the screen

---

## OPERATING THE MASK

---

The method you use to raise and lower a mask depends on the type of switch control device you have selected.

When you lower or retract a mask, it will stop at its preset limit.

### **Caution**

**Do not operate the motor when any of the following occurs:**

- ◆ **The unit emits any smoke, heat, abnormal noise or unusual odor.**
- ◆ **The unit is damaged in some way, such as damage from a water leak.**

**If any of these situations occur, call a qualified service person.**

The motor is designed to be used for short operations such as lowering the mask in preparation for viewing. The motor is not designed for continuous duty. If the motor operates continually for more than a few minutes, it may automatically shut off to prevent damage from overheating. If the motor occasionally needs to be run more than normal, for example during initial setup and positioning, allow time for the motor to cool down.

In general, when a mask is not in use, you should store it in the fully retracted position.

---

## ADJUSTING THE MASK EXTENSION

---

### **Caution**

**Improper adjustment of the limit switches can cause irreparable damage to a mask itself, resulting in voiding the factory warranty.**

The extension and retraction limit switches have been preset at the factory. In general, we advise you to avoid readjusting these switches.

In some cases, to enable proper alignment of the displayed image on the screen, you may need to adjust the extension of a mask. If adjustment to the extension is necessary, carefully follow these instructions.

### **Warning!**

**A mask is fully retracted when the batten is behind the panel of the frame. Do not attempt adjustments with a retraction (UP) limit switch that will further retract a mask. Incorrect adjustment of that switch will cause severe mask damage. Please consult the factory if you have any questions.**

---

## Modifying the extension of the mask

---

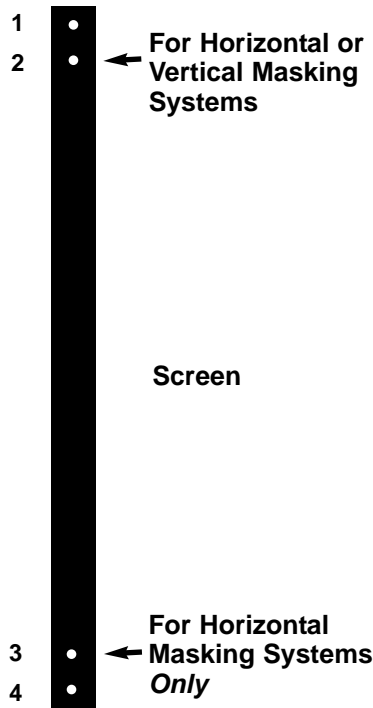

**Figure 15:** Limit switches; DOWN switches for masks are 2 and 3.

You can increase the extension of a mask up to 3" / 7.6 cm past the factory preset stop, or you can decrease the extension from the factory preset stop. Do not attempt to modify a mask extension beyond these recommended amounts.

The limit switches are located on the head of the motor and can be accessed through openings located on the left side of the frame, as shown in Figure 15.

Horizontal mask units have limit switches at the top and bottom of the screens, a set for each roller tube.

### Warning

**The UP limit switch(es) retract the batten(s) further into the frame. Adjusting them is not advised. Refer to 1 and 4 in Figure 15.**

To increase a mask's fully extended (mask down) stop position:

1. Lower the mask to its current stop position.
2. Locate the down limit switch(es) located on the left side of the frame. Refer to 2 and 3 in Figure 15. Use a screwdriver to turn the switch in a counterclockwise direction. If the power is on, the mask will drop incrementally as the switch is turned.

**Note:** One complete turn of the switch will make approximately a 1/2" / (1.3 cm) change in the mask's stop position.

To decrease the mask extension:

1. Lower and stop the panel when it is extended about halfway down.
2. Locate the down limit switch(es) located on the left side of the frame. Refer to 2 and 3 in Figure 15. Use a screwdriver to turn the switch in a clockwise direction.

**Note:** One complete turn of the switch will make approximately a 1/2" (1.3 cm) change in the mask's stop position.

3. Activate the mask in the down direction until it reaches the newly reduced stop position. Repeat this procedure until the desired stop position is reached.

Once you have made the adjustment, whenever you lower the mask, it will automatically stop at the new position.

**Note:** It is recommended that you make a note of any changes made to the factory preset.

---

## SCREEN CARE AND CLEANING

---

With reasonable care, you may expect many years of trouble-free use of your Stewart projection screen.

We encourage you to keep your screen clean. To protect your screen when it is not in use, store it in the fully retracted position.

Avoid getting any foreign material on the screen, as cleaning may prove very difficult. It may not be possible to remove scratches, paint, ink, etc.

### **General maintenance**

---

The screen surface on your screen is delicate. Special attention to these instructions should be followed when cleaning.

- ◆ A draftsman-style brush may be used to lightly whisk away any loose dirt or dust particles. (This type of brush is usually available at office supply stores.) Stewart Filmscreen has an optional screen cleaning kit that contains the proper type of brush. Contact your dealer if you would like to obtain this cleaning kit.
- ◆ For tougher spots, use a solution of mild detergent and water. Rub lightly using a sponge. Blot with a damp sponge to absorb excess water. Residual water marks will evaporate within a few minutes. Let the screen air dry completely before retracting.

Do not use any other cleaning materials on the screen. Contact the factory if you have questions about removing difficult spots.

### **Velux covering**

---

- ◆ Use a lint roller to remove particles from the Velux material.
- ◆ A brush can be used to comb (lift) the nap of the Velux material to help eliminate depression marks.

<b>Caution</b>
----------------

<b>Do not use chemicals or liquid to clean the fabric.</b>
--

### **Replacement parts and service**

---

No user-serviceable parts are contained within the unit. Contact your dealer or the factory if you require part replacement or service.

# TROUBLESHOOTING

Refer to the following guidelines if you encounter a difficulty in the operation of your Stewart Filmscreen. Problems related to electrical or motor function may require a qualified service person or electrician.

Should you have a problem that is not addressed here, call the Stewart Filmscreen Corporation.

Problem description	Probable cause	Action to take
Mask won't operate.	No AC power available. Outboard switching problem.	Check to see if the circuit breaker has switched off. Reset if needed. Check outboard switching apparatus. Check voltage availability. Contact an electrician.
Mask won't roll up or down (even though power is available).	Bad connection at switch. Polarity of VICS line may be bad.	Have an electrician or qualified service person check the connection as follows: <ul style="list-style-type: none"> <li>· If you have a <i>high voltage control switch</i>, check switch line connections.</li> <li>· If you have a <i>low voltage control unit</i>, check switch-line connections.</li> <li>· If you have a <i>VICS</i>, check line connections, or the mini plugs at the screen input or projector output. Check 12V DC line for correct polarity. Contacts may be sticking—tap relay to free contacts.</li> </ul>
Mask roller chatters when power is activated.	Can be caused by voltage drop, bad connections, or a defective switch.	Have an electrician or qualified service person check all hook-ups including all outboard wiring.
Unit hums in up mode. (Mask has already retracted.)	The mask batten is retracting too far into the frame. <b>Failure to correct can damage motor. Do not use the unit until this problem is resolved.</b>	Have a qualified service person adjust the UP limit switch. Turn the adjusting screw clockwise. See pp. 16-17 of this manual.
Mask drops when up direction is activated (grinding noise occurs).	Drop in voltage.	Mask motor requires full voltage. Have an electrician or qualified service person check available voltage.
Motor shuts off. Motor has been in use for more than 2 minutes.	Motor is designed for short operations (lowering and retracting), not continuous duty. Longer operation, such as during setup and positioning, causes the motor to overheat and shut off.	Allow the motor to cool down. Complete cooling can take an hour or more. Heat gain is cumulative and takes time to dissipate. If motor use is initiated before it has cooled completely, the motor will shut down again when it reaches maximum temperature.
Any controller (e.g., STI, LVC, etc.) fails to operate motor.		

<b>Problem description</b>	<b>Probable cause</b>	<b>Action to take</b>
Mask continues past bottom stop position.	White limit switch is out of adjustment.	Readjust the DOWN limit switch. See pp. 16-17 of this manual.
Batten retracts too far into frame.	Yellow limit switch out of adjustment. <b>Failure to correct can damage motor. Do not use the unit until this problem is resolved.</b>	Have a qualified service person readjust the UP limit switch. See pp. 16-17 of this manual.
Dirt, finger prints, marks, etc. on screen surface.	Improper handling of screen.	Brush off or use a mild detergent solution with clean rag or cotton swab.
Horizontal mask jams upon retraction.	The unit was not level and plumb when mounted.	Remount the unit making sure that it is level and plumb.

---

## PRODUCT WARRANTY

---

This warranty covers defects in materials and workmanship for a period of one (1) year from the date of installation, not to exceed fifteen (15) months from the date of shipment, provided this product is installed in a normal environment and maintained according to written instructions in the product Owner's Manual. Stewart Filmscreen warrants against loss of usefulness, discoloration or deterioration of optical quality within the warranty period as a result of manufacturing or material defects.

A factory authorized returned screen arriving prepaid to our facility for inspection and proved defective due to an inherent manufacturing fault will be repaired or replaced by Stewart Filmscreen Corp. This warranty expressly does not cover any costs of removal, installation, framing, or other incidental costs to replacing the screen or returning it to the manufacturer.

Should you encounter a perceived product fault or problem, contact your dealer regarding application of this warranty.



**Stewart**  
Filmscreen Corporation®

**[www.stewartfilm.com](http://www.stewartfilm.com)**

1-800-762-4999 ♦ Fax (310) 326-6870