

Luxus

Standard and Optional Controls

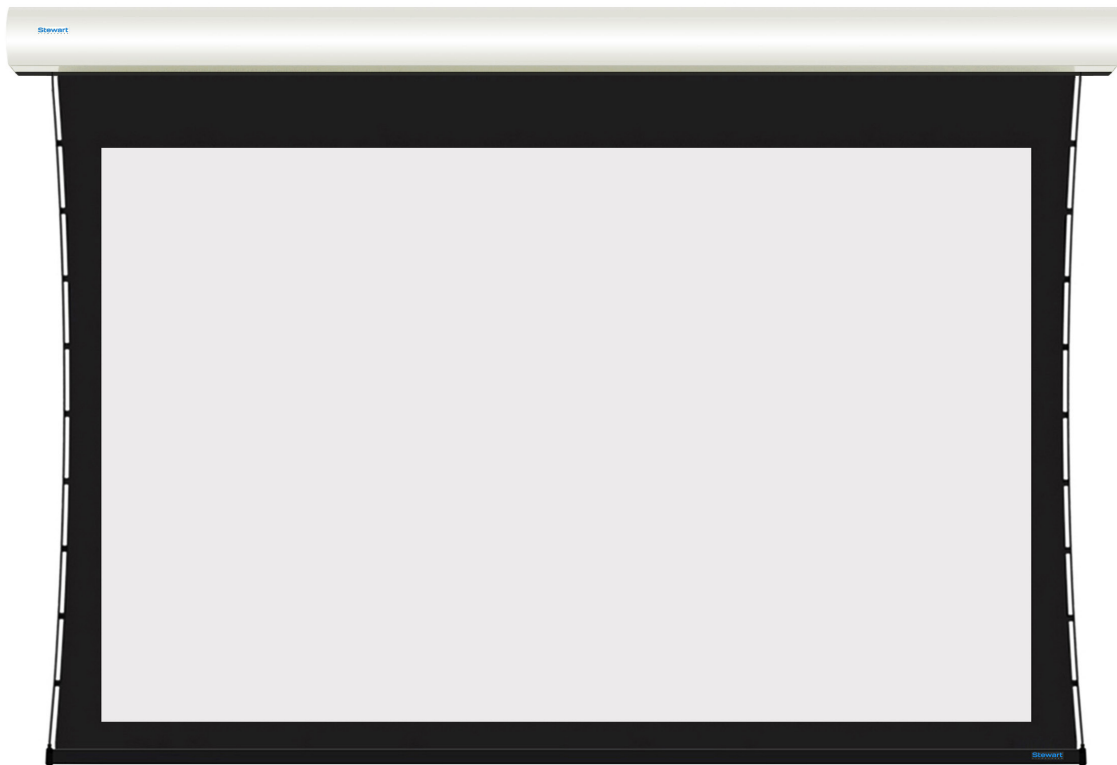

Stewart
F I L M S C R E E N

Producers of Professional Projection Screens

Standard Control		
Control	PowerOptions	Description
STI-100	115V / 220V	STI-100 is a multifunctional contact closure or screen trigger device. The STI-100 easily connects to any third party control system or video projector trigger outputs, and is supported by a decora type custom wall switch.
Optional Control		
Control	PowerOptions	Description
RTS Motor	115V / 220V	The optional Luxus RTS Motor uses a standard 120 VAC power cord. An integral RF receiver, and a dedicated hand held remote, operate the screen. The power cord plugs into a continuously powered AC outlet.



Luxus Switch Input Pinout STI-100

Contact Closure Switching

Pin 2 is also – 12 vdc if trigger is used.

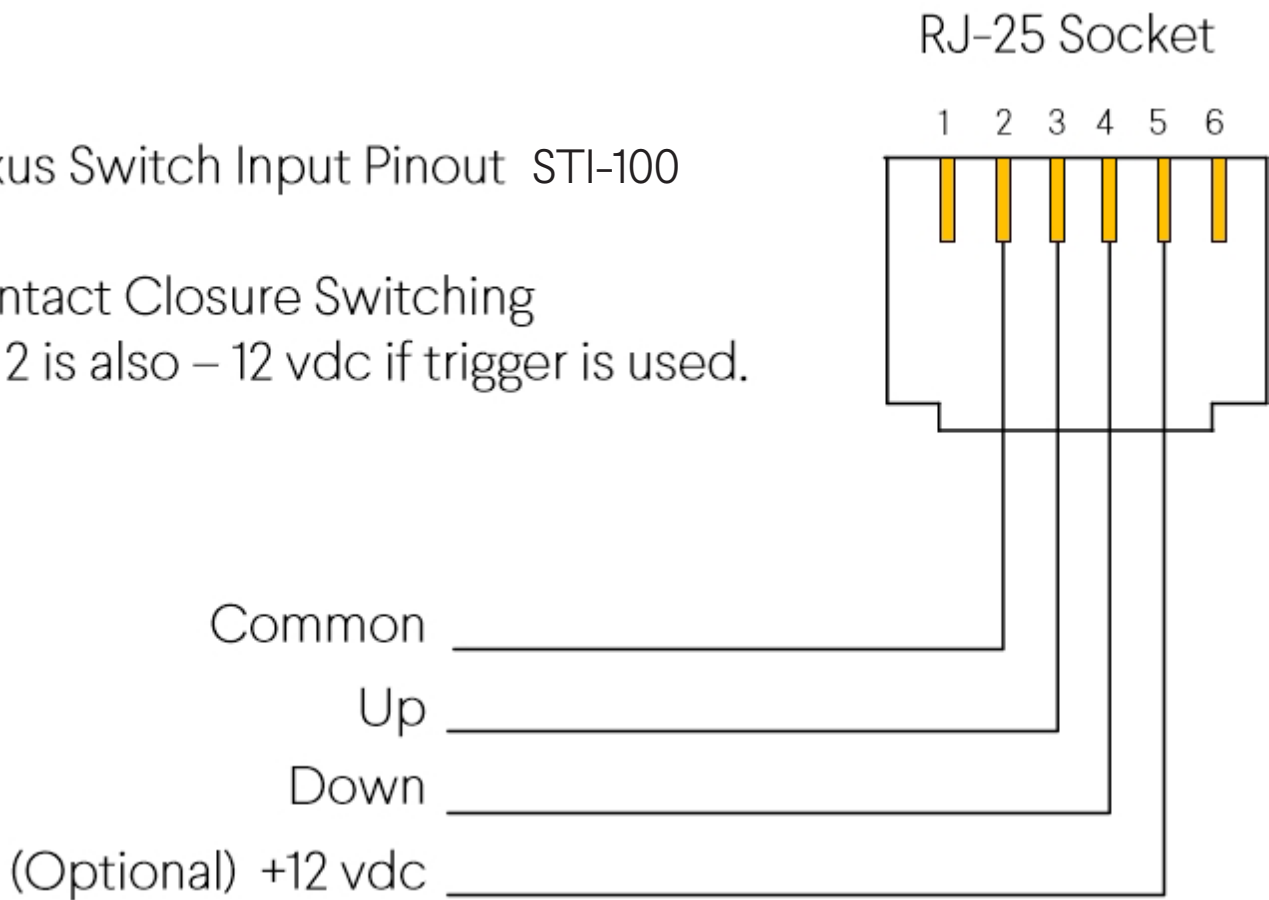

STI-100 is a multifunctional contact closure or screen trigger device. The STI-100 easily connects to any third party control system or video projector trigger outputs, and is supported by a decora type custom wall switch.

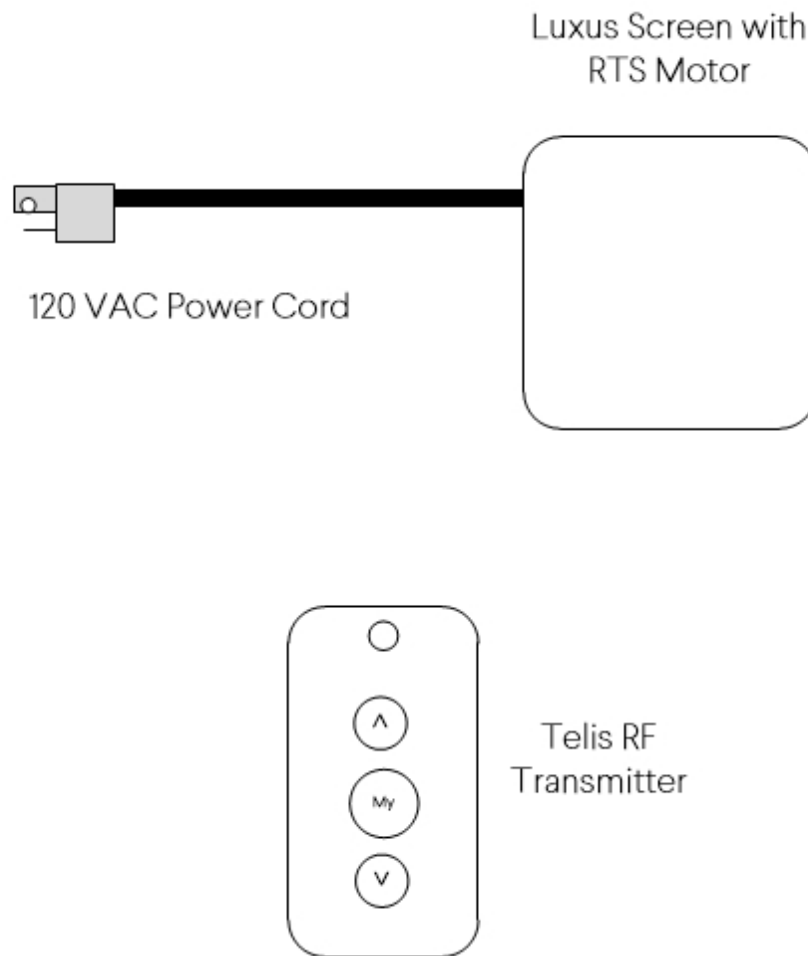

The optional Luxus RTS Motor uses a standard 120 VAC power cord. An integral RF receiver, and a dedicated hand held remote, operate the screen. The power cord plugs into a continuously powered AC outlet. With the addition of the Somfy MyLink device, the system becomes wi-fi discoverable and will facilitate control of the screen surface via tablets, phones and more.