

Cascade Medio

Retractable, Above Ceiling, Self-Finishing Screen System

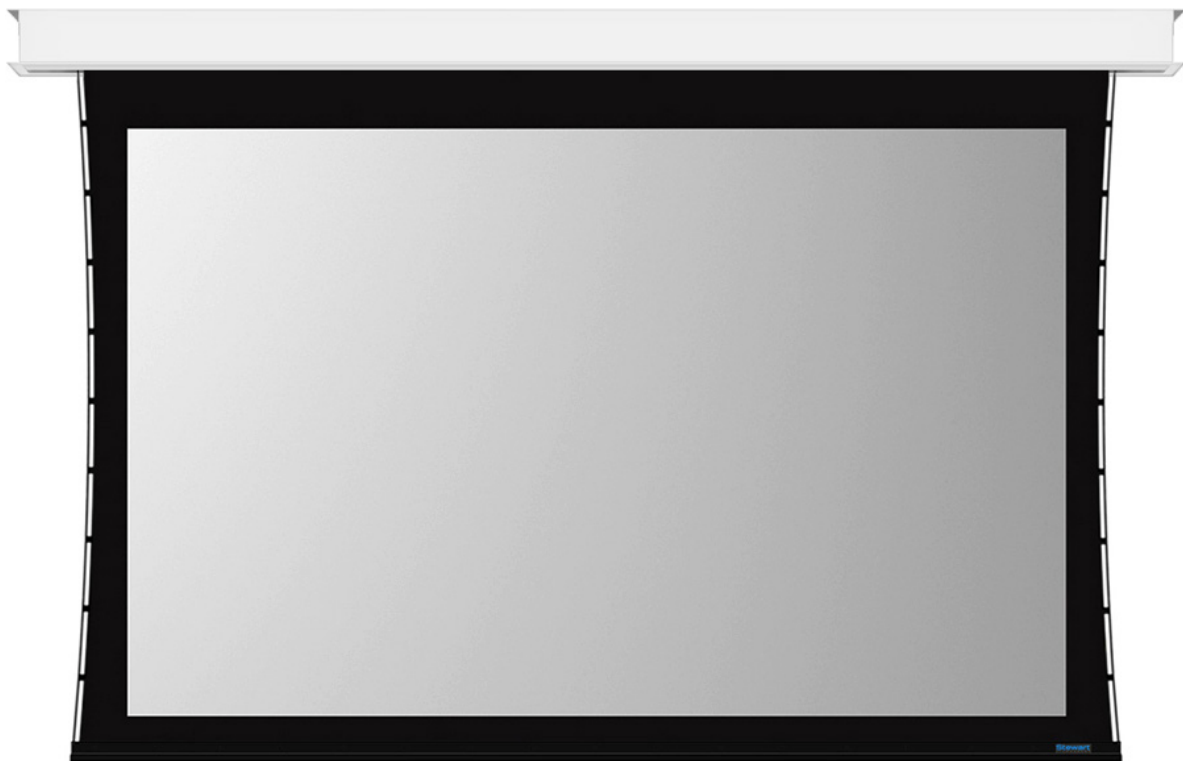

Printed in U.S.A. ©2020 Stewart Filmscreen Corporation
Stewart Filmscreen reserves the right to make changes to the product specified in this document.
Sizes and specifications subject to change without notice at Manufacturer's discretion. From time to time, this
document is updated. Current versions of documentation are posted on the Stewart Filmscreen website at:
www.stewartfilmscreen.com

Cascade Medio

OWNERS MANUAL

Contents

To the Owner	4
Preparing the Installation	5
Product Dimensions	7
Hanging the Case	8
Electrical Hookup	9
Standard Control - Low Voltage 3-Button Switch	10
Optional Control - Infrared Remote	12
Operating the Screen.	14
Adjusting the Screen Extension	15
Caring for & Cleaning the Screen	17
Troubleshooting	18
Product Warranty	20
Maintenance Notes.	21

TO THE OWNER

Congratulations on your purchase of one of the finest optical viewing screens available anywhere in the world! Please take a moment to review this manual as it will help ensure you many years of trouble-free service from your new Stewart Filmscreen product.

About the Cascade Medio

Supporting an image width up to seventeen feet, Cascade Medio has a self-finishing ceiling flange for a look that virtually disappears.

PREPARING THE INSTALLATION

- ▶ Before proceeding with the installation of this screen, take time to thoroughly read and understand these installation instructions.
- ▶ All electrical wiring installations must conform to local and national codes and should be performed by qualified service personnel.
- ▶ There are no user-serviceable parts contained within the unit.

Preparation

Specifications regarding the individual screen dimensions, weight, etc. are provided by the factory when the unit is ordered.

Before beginning the installation:

- ▶ Check the specifications for the type of mounting and switch control to be used.
- ▶ Ensure that the mounting area and electrical connection are prepared.
- ▶ Check the size and weight of the screen to be installed so that you can plan for the number of people required for the mounting procedure. You need at least two people to mount standard size screens; more are needed for larger, heavier screens.

You will need:

- ▶ Enough ladders and/or hydraulic lifts for personnel supporting the screen during the mounting process
- ▶ A level
- ▶ Fasteners appropriate for the surface on which the screen is being mounted.

Note: This manual refers to “AC” to represent electrical power. Your location may use 120 V, 220 V, or other electrical power. Screen systems are manufactured using the electrical power type specified for the location. Use appropriate power sources for your location.

CAUTION

During installation, do not place the unit on an unstable cart, stand, table, or ladder. The unit may fall, causing injury and damage to the unit.

PREPARING THE INSTALLATION (CONTINUED)

FACTORY ADVISORY

The factory advises against installing a concealed or recessed electrical projection screen permanently. You must be able to access the external end plates should future service to the screen roller assembly be necessary.

Suggested solutions for removing the unit include:

- ▶ A removable ceiling cover plate under the mounting location.
- ▶ Access to the unit through an attic or overhead space.

UNPACKING

Be sure to unpack carefully in a clean area. If you plan to repack your screen and hardware for transportation to another location, you may wish to photograph or make a note of how it was packed. Keep the packing material.

⚠ CAUTION

Do not stand on the package or store it vertically on its end. This will cause screen damage. If you are not going to install the screen immediately, make sure it remains horizontal during storage.

1. Do not remove the wrapping paper rolled with the screen. You should remove it only after the unit is hung and all electrical connections have been made.
2. Remove the batten lock-down screws located on the back side of the case.

⚠ WARNING!

Failure to remove the batten lock-down hardware can result in permanent damage to the screen.

PRODUCT DIMENSIONS

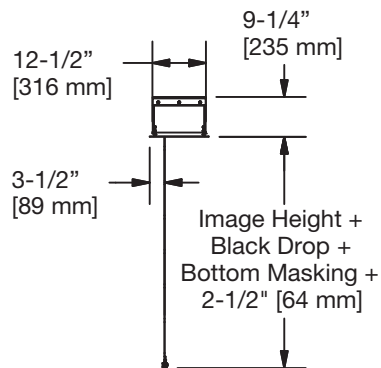
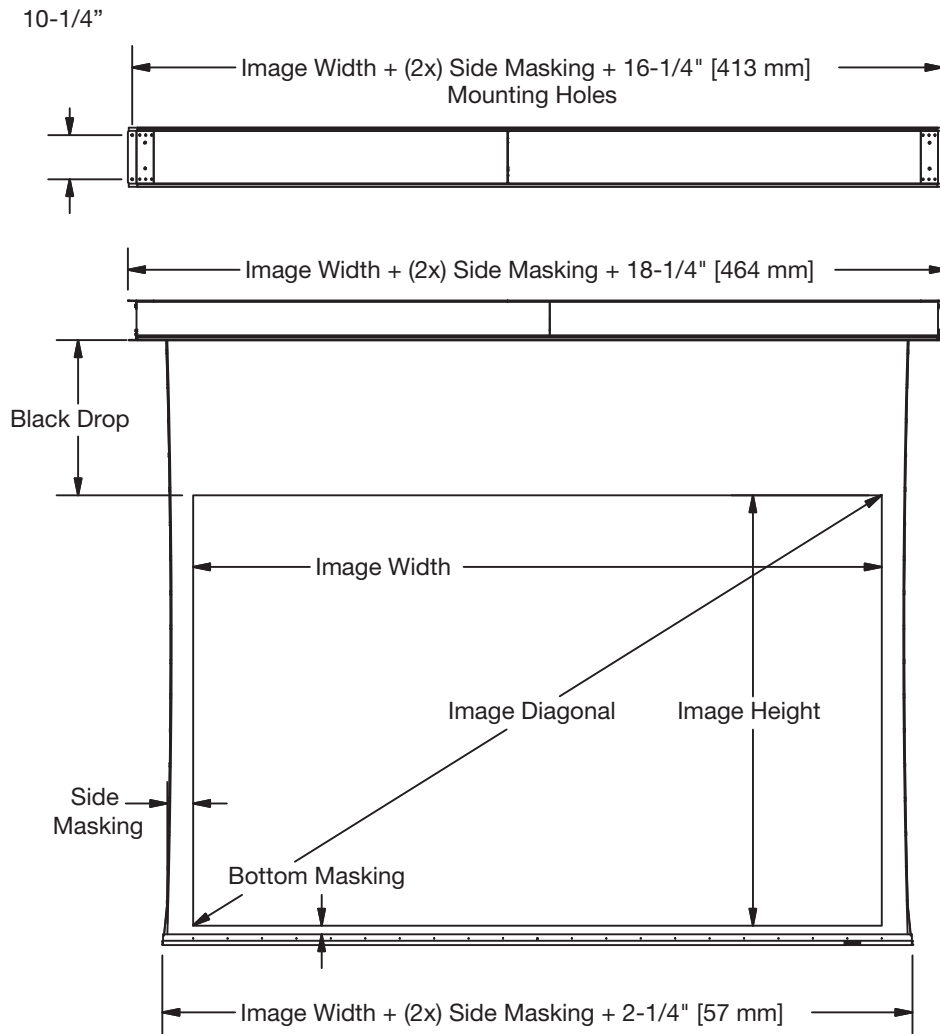

HANGING THE CASE

Professional mounting techniques should be used. Stewart Filmscreen can not be liable for substandard or faulty installations.

⚠ CAUTION

During installation of the Torrent, be advised that damage can occur to the screen. Perform the following actions to avoid damage:

- ▶ Wear clean gloves throughout the installation process to prevent damage to the screen housing or screen material.
- ▶ Make sure that the screen batten never contacts or strikes any objects as damage may occur.

Make sure that you mount the screen so that the electrical box is on the left side (audience left).

The Torrent is ready to be installed in a ceiling or soffit. A false ceiling is not intended to support the weight of a Torrent. If enclosing the Torrent in a ceiling, make sure to provide 6" x 12" / 152 - 305 mm access panels for future service.

The screen can be bolted directly to the support structure or suspended. If the unit is to be mounted to plaster, drywall, masonry, or other type of surface, use appropriate fasteners.

1. Install the unit onto the support structure. Refer to Figure 1.
2. Make sure the unit is level.



Figure 1: Hanging the Case

ELECTRICAL HOOKUP

⚠ CAUTION

Professional techniques should be used when making any electrical connection. A qualified electrician should perform these procedures.

Be sure to follow all standard safety procedures for installing electrical devices.

Do not disassemble or alter the configuration of the motor or the unit's electrical connections. This may cause injury to you or damage to the product.

The electrical connection should be made only to the type of power source indicated on the marking label.

The motor requires standard AC power (unless an alternate voltage has been specified).

All connections are made to the electrical box on the side of the unit (audience left).

There are various control options available. Follow the installation procedure for your specific control option for power connection.

The use of wire nuts is acceptable and suggested for wiring.

STANDARD CONTROL - LOW VOLTAGE 3-BUTTON SWITCH

The Stewart Filmscreen low voltage control allows the use of low voltage wire to connect to the supplied 3-position 24V momentary wall switch.

PREPARING THE CONNECTION

Before making the electrical connections, you need:

- ▶ An available AC constant power source
- ▶ A 4-conductor switch hookup cable (4-conductor bell wire or category 5 cable is typically used for long runs)
- ▶ Cat 5, multi-conductor unshielded, or similar type electronic cable can be used to connect the 3-button switch to the LVC. The recommended wire gauge is 20 to 24 AWG. Use plenum-rated cable when required.

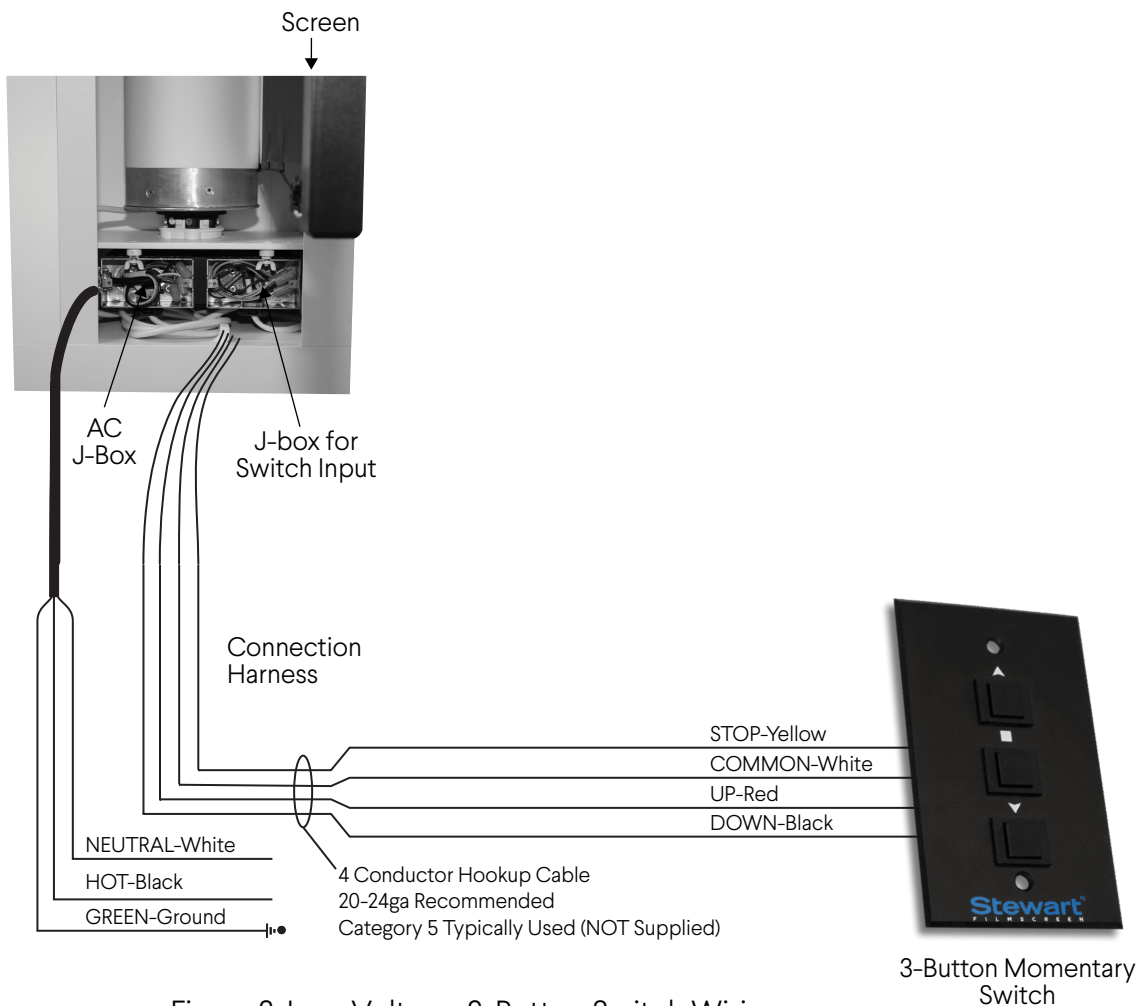

Figure 2: Low Voltage, 3-Button Switch Wiring

STANDARD CONTROL - LOW VOLTAGE 3-BUTTON SWITCH (CONTINUED)

MAKING THE CONNECTIONS

Figure 2 illustrates the connections.

1. Remove the dust cover. It is held into position by two bolts that are located at each end of the screen slot. Once these bolts are removed (by hand), the dust cover slides back away from the front of the case and then downward. It is advisable to have a second person assist while removing the dust cover.
2. Connect the 4-conductor hookup cable to the connection harness coming from the J-Box used for “switch input.” (Knock-outs are available on the top and back sides of the housing for wire pulls to access J-Box.)
3. Connect the hookup cable to the 3-button switch.
4. Connect the main AC power source to the AC J-Box. (Knock-outs are available on the top and back sides of the housing for wire pulls to access J-Box.)
5. A parallel connection to an outboard audio-visual switching network can be made at this time (optional).

OPERATION

Press the “Down” button once and the screen will automatically extend fully to its pre-set limit. Press the “Up” button once and the screen will automatically retract back into the case. If a custom position is desired, simply press the “Stop” button at any time during the screen’s deployment or retraction.

Note: See the section on Adjusting the Screen Extension for information regarding the default limits by which the screen can be adjusted up or down from the factory pre-set.

OPTIONAL CONTROL - INFRARED REMOTE

The optional Stewart Filmscreen infrared remote control allows control of the screens from anywhere in the room.

Note: The distance between the hand-held remote control and the receiver can be up to 50 feet / 15 m. It is necessary to have uninterrupted line-of-sight between the remote and the receiver.

PREPARING THE CONNECTION

Before making the electrical connections, you need:

- ▶ An available AC constant power source
- ▶ A 4-conductor switch hookup cable (4-conductor bell wire or category 5 cable is typically used for long runs)
- ▶ Cat 5, multi-conductor unshielded, or similar type electronic cable can be used to connect the 3-button switch to the LVC. The recommended wire gauge is 20 to 24 AWG. Use plenum-rated cable when required.

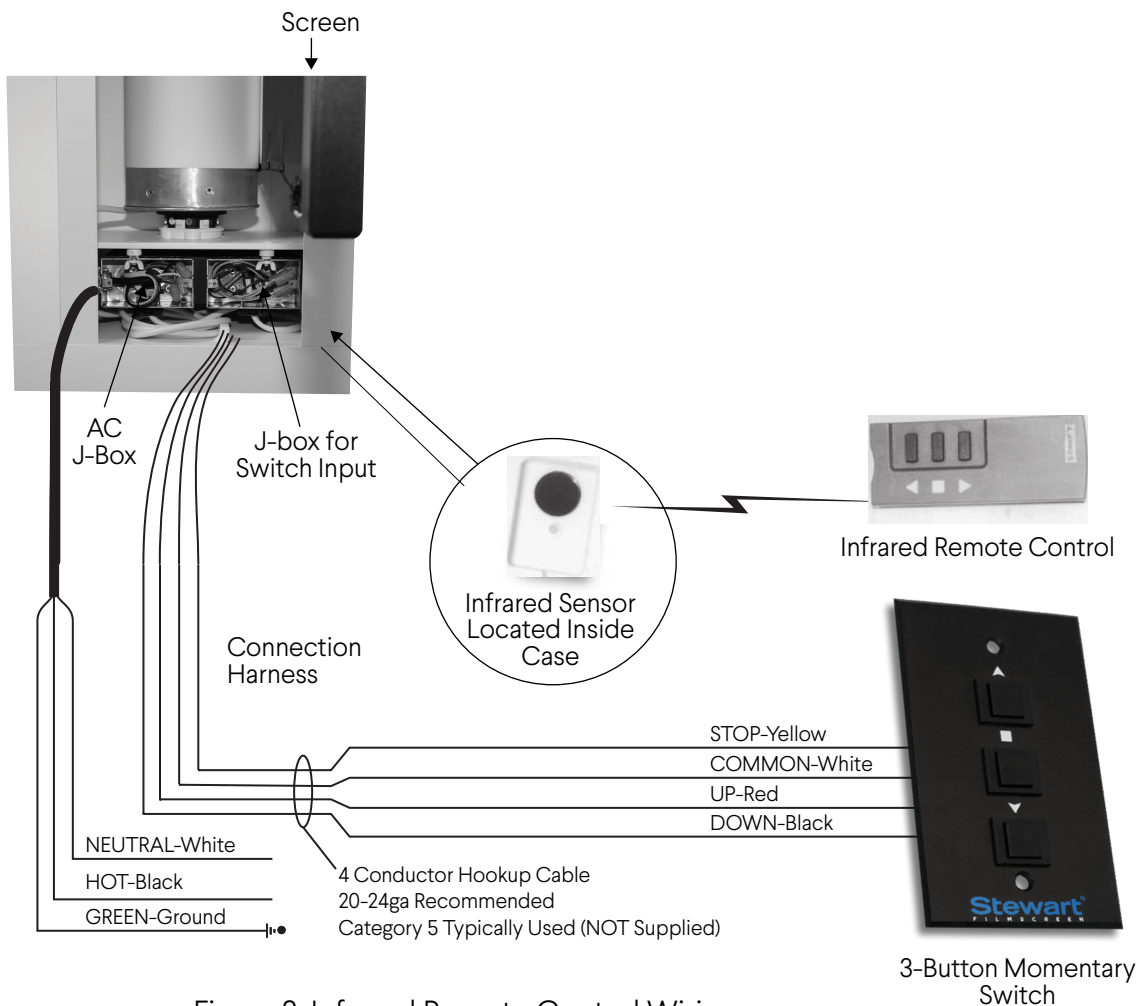

Figure 3: Infrared Remote Control Wiring

OPTIONAL CONTROL - INFRARED REMOTE (CONTINUED)

MAKING THE CONNECTIONS

Figure 3 illustrates the connections.

1. Remove the dust cover. It is held into position by two bolts that are located at each end of the screen slot. Once these bolts are removed (by hand), the dust cover slides back away from the front of the case and then downward. It is advisable to have a second person assist while removing the dust cover.
2. Connect the 4-conductor hookup cable to the connection harness coming from the J-Box used for “switch input.” (Knock-outs are available on the top and back sides of the housing for wire pulls to access J-Box.)
3. Connect the hookup cable to the 3-button switch.
4. Connect the main AC power source to the AC J-Box. (Knock-outs are available on the top and back sides of the housing for wire pulls to access J-Box.)
5. A parallel connection to an outboard audio-visual switching network can be made at this time. (optional)

OPERATING THE SCREEN

DESCRIPTION

The method you use to raise and lower the screen depends on the type of switch control device you have selected.

When you lower or retract the screen, it will stop at its preset limit. If an obstacle (such as a person or furniture) is in the path of the screen as it is lowered, use the switch control to stop the screen's motion (it will not automatically stop if it hits an obstacle).

The motor is designed to be used for short operations such as lowering the screen in preparation for viewing. The motor is not designed for continuous duty. If the motor operates continually for more than a few minutes, it may automatically shut off to prevent damage from overheating. If the motor occasionally needs to be run more than normal, for example during initial setup and positioning, allow time for the motor to cool down.

In general, when the screen is not in use, you should store it in the fully retracted position.

⚠ CAUTION

Do not operate the motor when any of the following occurs:

- ▶ The unit emits any smoke, heat, abnormal noise or unusual odor.
- ▶ The unit is damaged in some way, such as damage from a water leak.

If any of these situations occurs, call a qualified service person.

ADJUSTING THE SCREEN EXTENSION

⚠ CAUTION

Improper adjustment of the limit switches can cause irreparable damage to the screen itself, resulting in voiding the factory warranty.

DESCRIPTION

The extension and retraction limit switches have been preset at the factory. In general, we advise you to avoid readjusting these switches.

In some cases, to enable proper alignment of the displayed image on the screen, you may need to adjust the extension of the screen. If adjustment to the extension is necessary, carefully follow these instructions.

WARNING!

The screen is fully retracted when the batten is flush with the bottom of the case. Do not attempt adjustments with the yellow retraction (UP) limit switch that will further retract the screen. Incorrect adjustment of the switch will cause severe screen damage. Please consult the factory if you have any questions.

ADJUSTING THE SCREEN EXTENSION

You can increase the extension of the screen up to 3" (7.6 cm) past the factory preset stop, or you can decrease the extension by approximately 4-6" (10 - 15 cm) from the factory preset stop. Do not attempt to modify the screen extension beyond these recommended amounts.

The limit switches are located on the left side (audience left) of the screen roller tube inside the case, after removing the dust cover, as shown in Figure 4.

To increase the screen's fully extended (screen down) stop position:

1. Lower the screen to its current stop position.
2. Remove the dust cover to locate the white extension (down) limit switch on the left side of the screen tube (audience left). The dust cover is held into position by two bolts that are located at each end of the screen slot. Once these bolts are

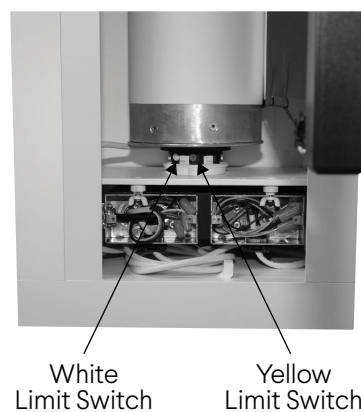

Figure 4: Underside View with Dust Cover Removed

ADJUSTING THE SCREEN EXTENSION (CONTINUED)

removed (by hand), the dust cover slides back away from the front of the case and then downward. It is advisable to have a second person assist while removing the dust cover.

3. Use a small electrician's style screwdriver or a 5/32" (.4 cm) hex wrench to turn the white extension (down) limit switch in a counterclockwise direction. If the power is still on, the screen will drop incrementally as the switch is turned.

Note: One complete turn of the switch will make approximately a 1" (2.5 cm) change in the screen's stop position.

To decrease the screen extension:

1. Lower the screen until it is extended about halfway down.
2. Remove the dust cover to locate the white extension (down) limit switch on the left side of the screen tube (audience left). The dust cover is held into position by two bolts that are located at each end of the screen slot. Once these bolts are removed (by hand), the dust cover slides back away from the front of the case and then downward. It is advisable to have a second person assist while removing the dust cover.
3. Use a small electrician's style screwdriver or a 5/32" (.4 cm) hex wrench to turn the white extension (down) limit switch in a clockwise direction.

Note: One complete turn of the switch will make approximately a 1" (2.5 cm) change in the screen's stop position.

4. Activate the screen in the down direction until it reaches the newly reduced stop position. Repeat this procedure until the desired stop position is reached.

Once you have made the adjustment, whenever you lower the screen, it will automatically stop at the new position.

Note: The yellow "UP" limit switch is to stop the motor in the retracted position. We advise not adjusting this switch as to avoid possible screen damage should the switch get mis-adjusted.

It is recommended that you make a note of any changes made to the factory preset.

CARING FOR AND CLEANING THE SCREEN

With reasonable care, you may expect many years of dependable use of your Stewart projection screen. We encourage you to keep your screen clean. To protect your screen when it is not in use, store it in the fully retracted position. Avoid getting any foreign material on the screen, as cleaning may prove very difficult. It may not be possible to remove scratches, paint, ink, etc.

GENERAL MAINTENANCE

Treat your screen surface delicately. Special attention to these instructions should be followed when cleaning.

- ▶ A draftsman-style brush may be used to lightly whisk away any loose dirt or dust particles. (This type of brush is usually available at office supply stores.) Stewart Filmscreen has an optional screen cleaning kit that contains the proper type of brush. Contact your dealer if you would like to obtain this cleaning kit.
- ▶ Particles left on the screen when it is retracted into the case may form an impression on the screen surface. Periodically wipe the back of the screen with a clean damp cloth.
- ▶ For tougher spots, you can make a cleaning solution using a water-based detergent and warm water. To make the solution, mix one part Simple Green, 409, or other water based industrial cleaner with three parts warm water. Moisten a clean cotton cloth or Q-Tip with this solution, moisten the stained area, and gently lift off the stain. Never use an aggressive scrubbing action as you could damage the screen surface by removing the optical coating. Remoisten the area with clean water and dab dry with a clean sponge or cotton cloth. Any residual watermarks will evaporate on their own in a few minutes.

Do not use any other cleaning materials on the screen. Contact the factory if you have questions about removing difficult spots.

WEEKLY MAINTENANCE

To maximize the longevity of your Stewart screen we recommend the screen be deployed overnight at least once a week. If using a 3rd party control system to deploy your Stewart screen, you may be able to program the 3rd party system to automatically deploy your Stewart screen once a week.

REPLACEMENT PARTS & SERVICE

No user-serviceable parts are contained within the unit. Contact your dealer or the factory if you require part replacement or service.

TROUBLESHOOTING

Refer to the following guidelines if you encounter a difficulty in the operation of your Stewart Filmscreen product. Problems related to electrical or motor function may require a qualified service person or electrician. Should you have a problem that is not addressed here, call Stewart Filmscreen Corporation (310-784-5300) Toll free (1-800-762-4999).

Problem	Cause	Action Steps
Screen won't operate.	No AC power available. Outboard switching problem.	Check to see if the circuit breaker has switched off. Reset if needed. Check outboard switching apparatus. Check voltage availability. Contact an electrician.
Screen won't roll up or down (even though power is available).	Faulty connection at switch. Polarity of STI line may be bad.	Have an electrician or qualified service person check the connection as follows: <ul style="list-style-type: none"> ▶ If you have a low voltage control unit, check the switchline connections. ▶ If you have a screen trigger interface, check the module's line connections or the miniplugs at the screen input or projector output. Check 12V DC line for correct polarity. Contacts may be sticking. Tap relay to free contacts.
Screen roller chatters when power is activated.	Can be caused by voltage drop, bad connections, or a defective switch.	Have an electrician or qualified service person check all hookups including all outboard wiring.
Unit hums in up mode. (Screen has already retracted.)	The screen batten is retracting too far into the case. Failure to correct can damage motor and screen. Do not use the unit until this problem is resolved.	Have a qualified service person adjust the yellow UP limit switch.

TROUBLESHOOTING (CONTINUED)

Problem	Cause	Action Steps
Screen drops when up direction is activated (grinding noise occurs).	Drop in voltage.	Screen motor requires full voltage. Have an electrician or qualified service person check available voltage.
Screen continues past bottom stop position.	White limit switch is out of adjustment.	Readjust the white DOWN limit switch. See the section on Adjusting the Screen Extension.
Batten retracts too far into case.	Yellow limit switch out of adjustment. Failure to correct can damage motor and screen. Do not use the unit until this problem is resolved.	Have a qualified service person adjust the yellow UP limit switch.
Motor shuts off. Motor has been in use for more than 2 minutes.	Motor is designed for short operations (lowering and retracting), not continuous duty. Longer operation, causes the motor to overheat and shut off.	Allow the motor to cool down. Complete cooling can take an hour or more. Heat gain is cumulative and takes time to dissipate. If motor use is initiated before it has cooled completely, the motor will shut down again when it reaches maximum temperature.
Dirt, fingerprints, marks, etc. on screen surface.	Improper handling of screen.	Lightly brush off or use a mild detergent solution with a clean rag or cotton swab.
Indentations appear on screen surface.	Debris or particles adhering to screen due to static cling.	Check back of screen; gently brush debris away with a draftsman-style brush.

LIMITED ONE YEAR WARRANTY

STEWART FILMSCREEN CORPORATION (Stewart) warrants all products to the original purchaser only. Stewart products are guaranteed to be free from defects in materials and workmanship for a period of one (1) year from the date of purchase by the original purchaser or eighteen (18) months from date of manufacture, as defined in the serial number. Additionally, all products must be properly operated and maintained according to Stewart instructions and cannot be damaged due to improper handling or treatment after shipment from the factory. This warranty does not apply to equipment showing evidence of misuse, abuse, or accidental damage, including neglect caused by improper installation (i.e. proximity to hot lights, exposure to extreme heat or cold, exposure to excessive humidity, etc.)

Stewart on-site warranty repair services are not available for this product. Stewart's sole obligation under this warranty shall be to repair or to replace (at Stewart's sole discretion) the defective part of the merchandise. This warranty expressly does not cover any costs of removal, installation, framing, or other costs incidental to replacing the screen or returning it to Stewart. Returns for service should be made to your Stewart dealer. If it is necessary for the dealer to return the screen or part to Stewart, transportation (freight) expenses to and from Stewart are payable by the purchaser. Stewart is not responsible for damage in shipment. To protect against damage or loss in transit, insure the product and prepay all transportation expenses.

This warranty is in lieu of all other warranties, expressed or implied, including warranties as to fitness for use or merchantability. Any implied warranties of fitness for use, or merchantability, that may be mandated by statute or rule of law are limited to the one (1) year warranty period. This warranty gives you specific legal rights, and you may also have other rights which vary from state to state. In no event will Stewart be liable for sums in excess of the purchase price of the product. No liability is assumed by Stewart for expenses or damages resulting from interruption in operation of equipment, or for incidental, direct, or consequential damages of any nature. In the event that there is a defect in materials or workmanship of a Stewart Filmscreen product, you may contact our Customer Service Department at 1161 W Sepulveda Blvd, Torrance, California 90502- 2797 (310-784-5300) Toll free (800-762-4999).

IMPORTANT: This warranty shall not be valid and Stewart shall not be bound by this warranty if the product is not operated and maintained in accordance with Stewart's written instructions. Stewart Filmscreen Corporation shall not be liable for any and all consequential damage(s) occasioned by the breach of any written or implied warranty pertaining to the sale of a Stewart Filmscreen product in excess of the purchase price of the product sold.



xxx



The Reference for Stunning™
www.stewartfilmscreen.com

1161 W. Sepulveda Blvd., Torrance CA 90502 USA | 800.762.4999 | Tel: 310.784.5300 | Fax: 310.326.6870 | Email: request@stewartfilmscreen.com

©2020 Stewart Filmscreen. Specifications are subject to change without notice.