

Cima AC NT

Retractable, Above Ceiling Screen System



Stewart
F I L M S C R E E N

The Reference for Stunning™

Printed in U.S.A. ©2020 Stewart Filmscreen Corporation
Stewart Filmscreen reserves the right to make changes to the product specified in this document.
Sizes and specifications subject to change without notice at Manufacturer's discretion. From time to time, this
document is updated. Current versions of documentation are posted on the Stewart Filmscreen website at:
www.stewartfilmscreen.com

Cima AC NT

OWNERS MANUAL

Contents

To the Owner	4
Preparing the Installation	5
Product Dimensions	6
Installing the Screen Into the Ceiling.	7
Standard Controls:	
Keypad Control	8
Projector Trigger Control	9
Keypad & Projector Trigger Control	10
Optional Controls:	
Cima-Link Infrared Package	12
Cima-Link Ethernet Package.	13
Cima-Link RS232 Package	14
Operating the Screen.	15
Adjusting the Screen Extension	16-17
Caring for & Cleaning the Screen	18
Troubleshooting	19-20
Product Warranty	21

TO THE OWNER

Congratulations on your purchase of one of our highly versatile Cima projection screens representing “Top of the Class” in standard commercial and residential projection screens. Please take a moment to review this manual as it will help ensure you many years of trouble-free service from your new Cima by Stewart Filmscreen product.

ABOUT YOUR CIMA ABOVE CEILING NON-TENSIONED ELECTRIC SCREEN

The Cima Above Ceiling Non-Tensioned Electric Screen is designed for ease of installation. The Cima Above Ceiling Non-Tensioned features a self-finishing face-plate. There are no user-servicable parts contained within the unit.

IMPORTANT SAFETY INFORMATION

SAFETY PRECAUTIONS

- ▶ Carefully read the instructions appropriate for your needs.
- ▶ This screen must be installed by a qualified electrician.
- ▶ For supply connections, use wires rated for at least 75 C.
- ▶ Use copper or aluminum conductors.
- ▶ For indoor use only.
- ▶ Do not connect low-voltage to line-voltage power.
- ▶ Article 725-54(a), (1) Exception No. 3 (NEC) or Canadian CE Code Handbook, Rule 16-212, Sub Rule (4) requires segregation between line-voltage and Class 2 (low-voltage) circuits. Low-voltage / network wires should enter enclosure boxes through separated openings. Also, conductors shall be separated by at least 1/4” or segregated by barriers. Check with your local electrical inspector for compliance with local / national codes and wiring practices.
- ▶ Earth ground terminal connection must be made as shown in wiring diagrams.
- ▶ Proper short-circuit and overload protection must be provided at the circuit breaker distribution panel. You can use up to a 20A maximum circuit breaker with adequate short-circuit breaking capacity for your installation.

PREPARING THE INSTALLATION

The Cima Above Ceiling Non-Tensioned product can be controlled through a number of remote control devices, including keypads, dry contact outputs, and low-voltage trigger outputs. With the optional Cima-Link Controller Packages, your Cima screen can be controlled by local and remote Infrared, IP ethernet, and computer-based signaling sources such as those manufactured by Control4, AMX, Crestron, Elan Home Systems with RS-232-C or RS-485 interfaces.

⚠ CAUTION

To be installed and/or used in accordance with appropriate electrical codes and regulations.

You will need:

- ▶ Enough ladders for the personnel supporting the screen during the mounting process
- ▶ A level
- ▶ Fasteners appropriate for the surface on which the screen is being mounted

Note: This manual refers to “AC” to represent electrical power. Your location may use 120 V, 220 V, or other electrical power. Screen systems are manufactured using the electrical power type specified for the location. Use appropriate power sources for your location.

UNPACKING

1. Remove the outer plastic covering and white wrapping paper surrounding the screen case.
2. Do not remove the wrapping paper surrounding the screen roller. You should remove it only after the unit is hung and all electrical connections have been made.
3. Remove the batten lock-down screws located on the back side of the case.

WARNING!

Failure to remove the batten lock-down screws can result in permanent damage to the screen.

MOTOR WIRING

The Cima Non-Tensioned Above Ceiling’s screen motor is pre-wired at the factory. No additional motor assembly is required.

⚠ CAUTION

During installation, do not place the unit on an unstable cart, stand, table, or ladder. The unit may fall, causing injury and damage to the unit.

PRODUCT DIMENSIONS

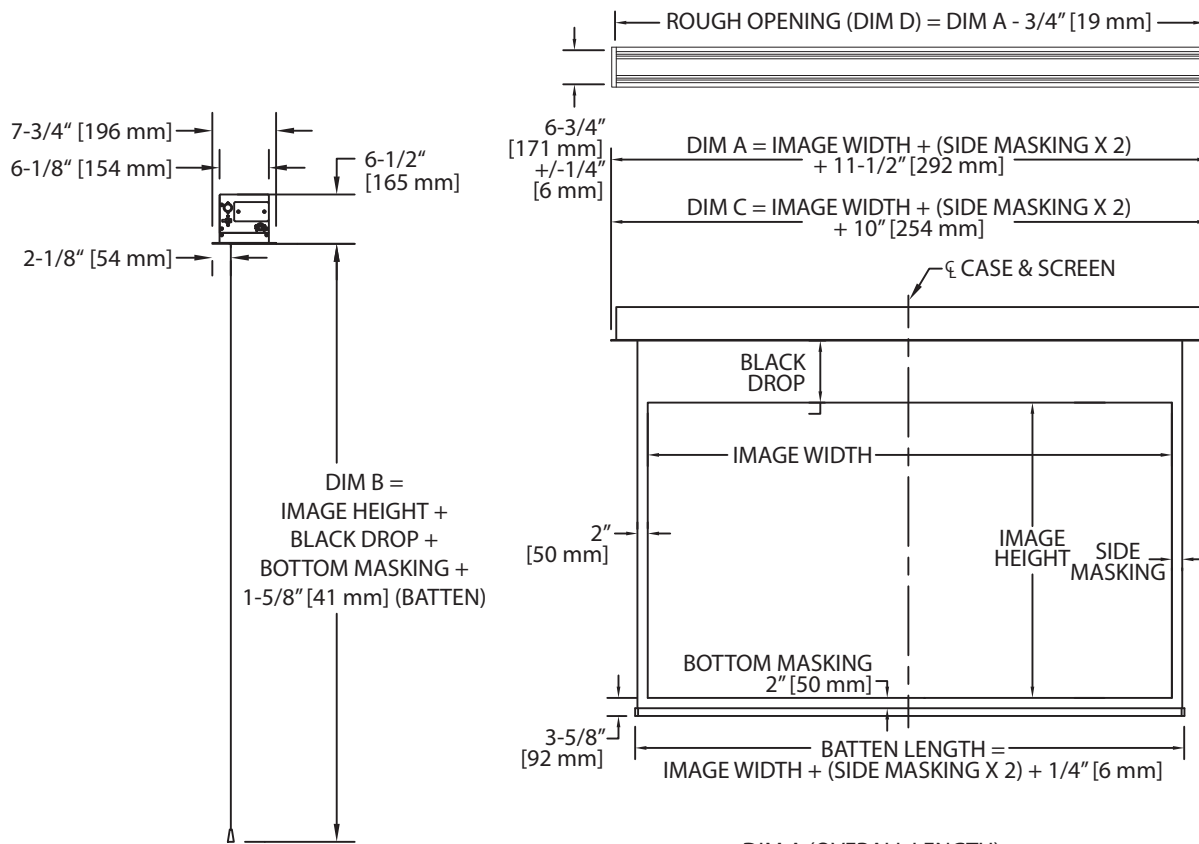

DIM A (OVERALL LENGTH)
DIM B (SCREEN OUT OF CASE)
DIM C (CASE LENGTH)
DIM D (ROUGH OPENING LENGTH)

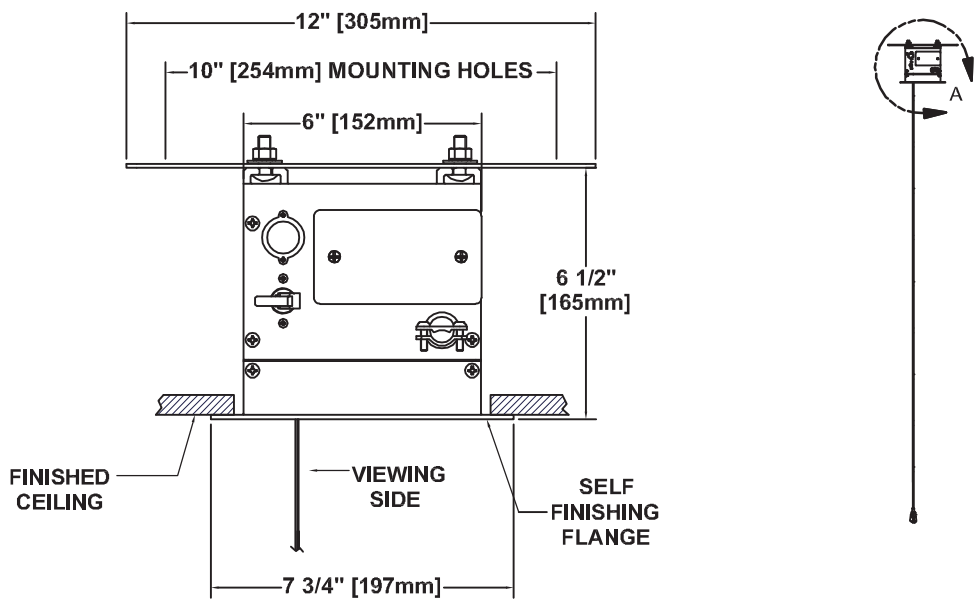

Detail A: Screen Sideview

INSTALLING THE SCREEN INTO THE CEILING

Professional mounting techniques should be used. Stewart Filmscreen cannot be liable for substandard or faulty installations.

⚠ CAUTION

During installation of the Cima Above Ceiling Non-Tensioned ElectriScreen into the ceiling opening, be advised that damage can occur to the screen. Perform the following actions to avoid damage:

- ▶ Wear clean gloves throughout the installation process to prevent damage to the screen housing or screen material.
- ▶ Make sure that the screen batten never contacts or strikes any objects as damage may occur.

Note: A false ceiling is not intended to support the weight of a Cima Above Ceiling Non-Tensioned ElectriScreen.

1. Remove the dust cover for easier access if desired.
2. Raise the screen into the ceiling.
3. Fasten the mounting brackets to the threaded rods or beams above the ceiling. (Note: The unit is usually suspended, as shown in Figure 1, but it can be secured to the ceiling using bolts or other appropriate fasteners as well.)
4. Make sure the bottom is flush with the finished ceiling.
5. Make sure the case is level.
6. Plug in the STI wiring and terminate the power.
7. Replace the dust cover as needed.

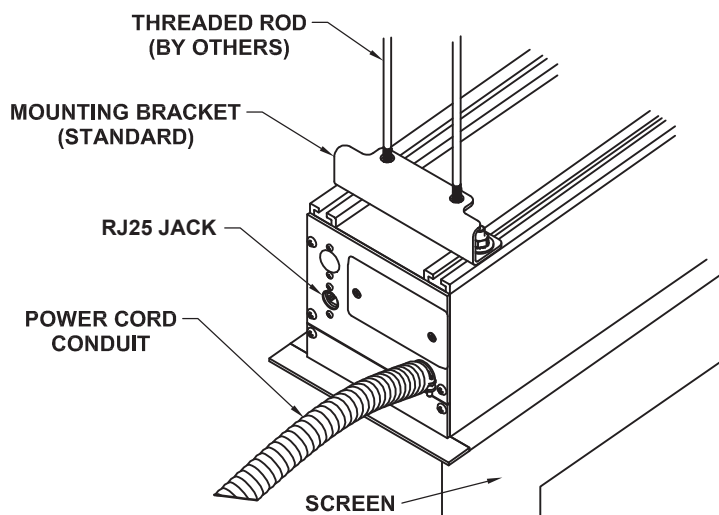

Figure 1: Overhead View Isometric

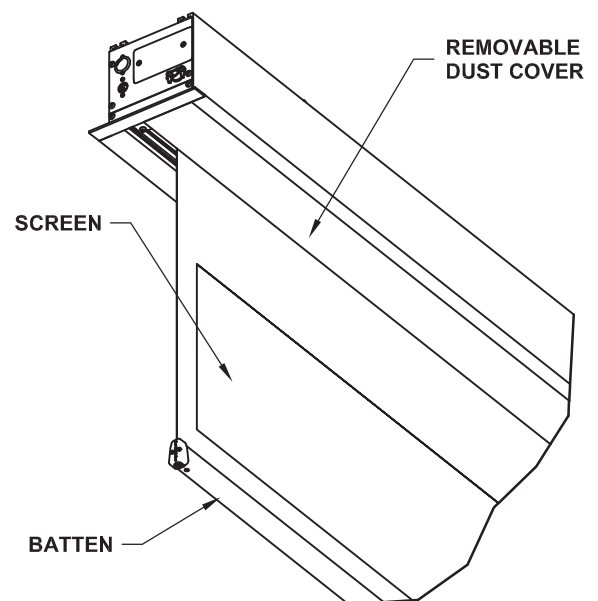

Figure 2: Underside View Isometric

STANDARD CONTROL - KEYPAD CONTROL

A standard, 3-button, low-voltage keypad is supplied for both the standard controller and the optional Cima-Link Controller Accessories.

MAKING THE CONNECTIONS

1. Connect the RJ25 cable to the keypad.
2. Connect the other end of the RJ25 cable to the Cima unit.

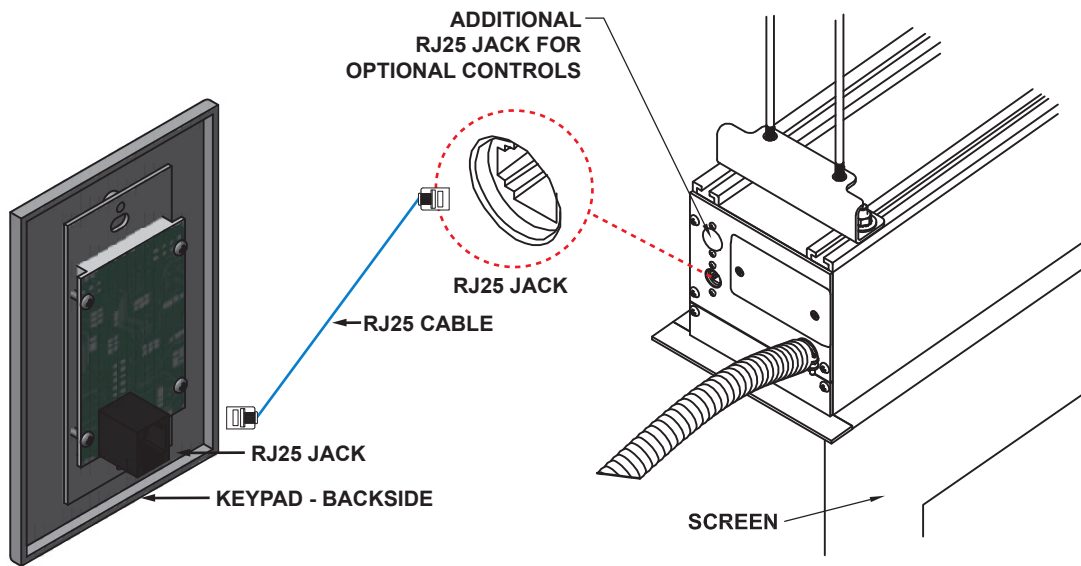

Figure 3: Keypad Connection

Note: The maximum length of the RJ25 cable shall not exceed 50’.

OPERATION

Press the “Down” button once, and the Cima screen will automatically extend fully to its pre-set limit, and then will power itself off. Press the “Up” button once and the Cima screen will automatically retract back into the case and power itself off. If a custom position is desired, simply press the “Stop” button at any time during the screen’s deployment or retraction. (See Figure 4)

Note: See the section on Adjusting the Screen Extension for information regarding the default limits by which the screen can be adjusted up or down from the factory pre-set.

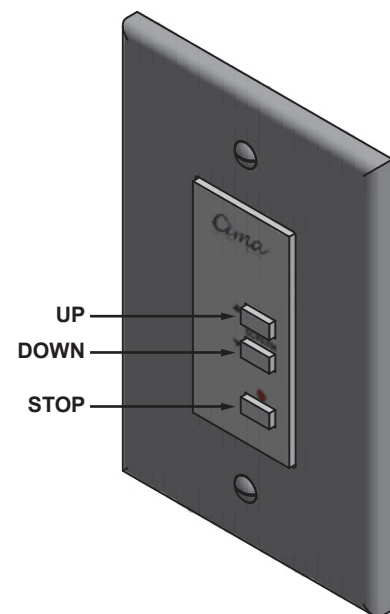

Figure 4: Keypad Face

STANDARD CONTROL - PROJECTOR TRIGGER CONTROL

MAKING THE CONNECTIONS

1. Connect a projector trigger cable to the projector. (Note: projector trigger cable not provided – the installer needs to make the cord from a RJ25 cord, cut one end off and add the mono plug onsite.)
2. Connect the other end of the trigger cable to the Cima unit. (RJ25 plug)

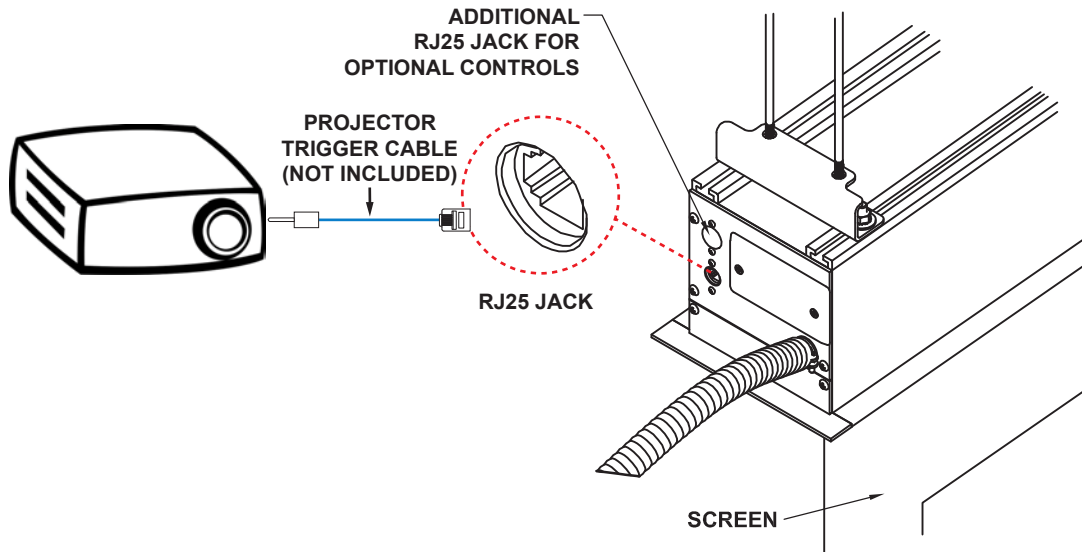

Figure 5: Projector Connection

HOW IT WORKS

When the projector is turned on or off a signal is sent to the controller within the motor and will trigger the screen to move up or down.

If there is a sudden change in direction, the motor is paused for 1/2 second before reversing direction. This is to prevent strain on the motor mechanism, and to prevent damage to any material controlled by the motor. Relays are automatically de-energized after 120 seconds of operation to reduce power consumption.

STANDARD CONTROL - KEYPAD & PROJECTOR TRIGGER CONTROL

MAKING THE CONNECTIONS

1. Connect the RJ25 cable splitter to the RJ25 jack in the Cima unit.
2. Connect the RJ25 cable and projector trigger cable to each jack in the splitter. (Note: projector trigger cable not provided – the installer needs to make the cord from a RJ25 cord, cut one end off and add the mono plug onsite.)
3. Connect the other end of the RJ25 cable and trigger cable to the jack on the projector and keypad.

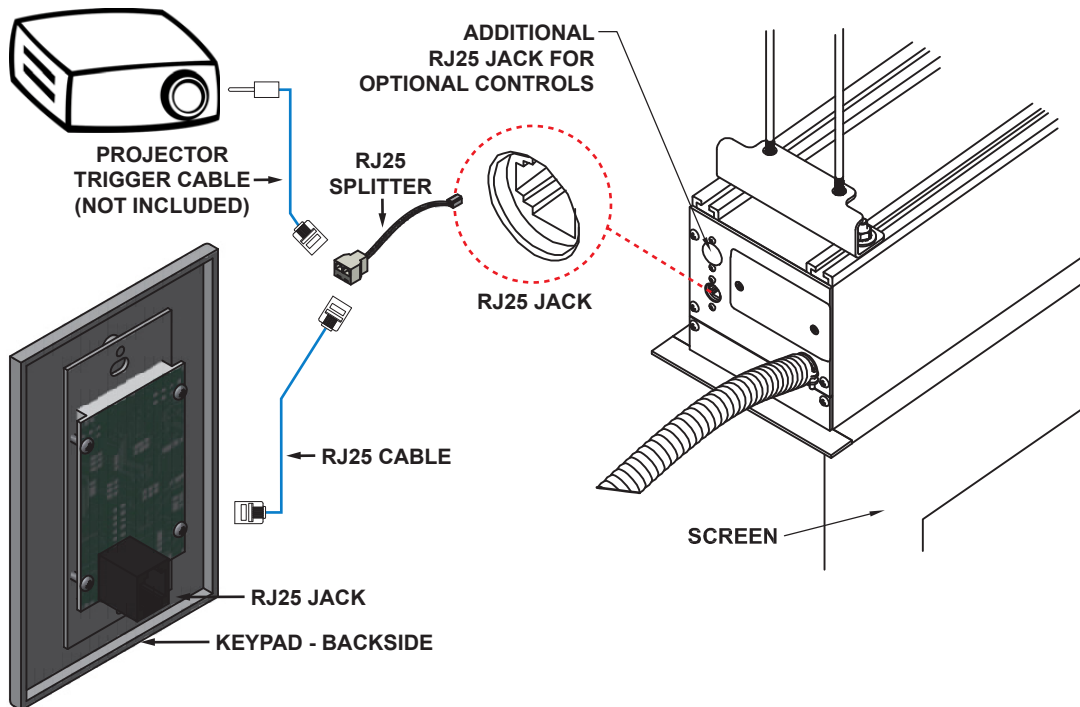

Figure 6: Keypad & Projector Connection

KEYPAD OPERATION

Press the “Down” button once and the Cima screen will automatically extend fully to its pre-set limit, and then will power itself off. Press the “Up” button once and the Cima screen will automatically retract back into the case and power itself off. If a custom position is desired, simply press the “Stop” button at any time during the screen’s deployment or retraction. (See Figure 4)

PROJECTOR OPERATION

When the projector is turned on or off a signal is sent to the controller within the motor and will trigger the screen to move up or down. If there is a sudden change in direction, the motor is paused for 1/2 second before reversing direction. This is to prevent strain on the motor mechanism, and to prevent damage to any material controlled by the motor. Relays are automatically de-energized after 120 seconds of operation to reduce power consumption.

OPTIONAL CONTROLS - CIMA-LINK CONTROLLER DESCRIPTION

The optional Cima-Link Controller (IMC-100C) is a state-of-the-art bi-directional communication AC motor controller designed to control your Cima projection screen and integrate with optional infrared remote, additional Cima screens, and 3rd party applications. Up to 255 Cima ElectriScreens can be linked together on any one span when connected together via the optional Cima-Link RS-232 Serial Package or Cima-Link Ethernet Package.

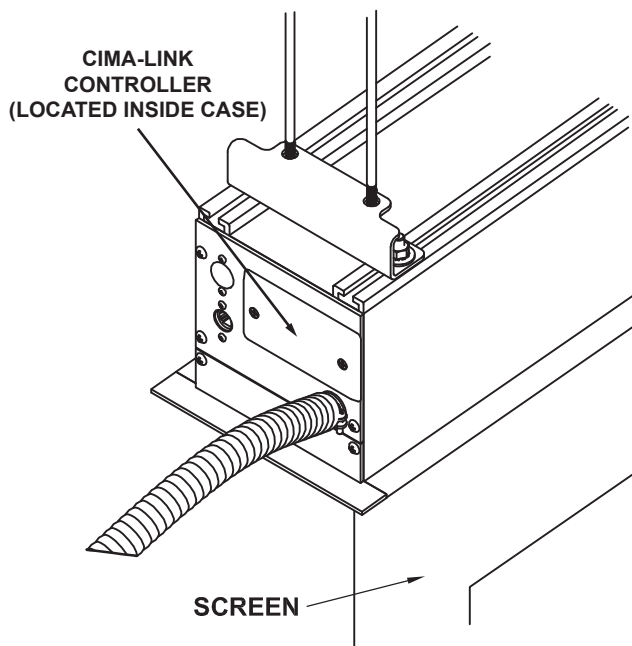

Figure 7: Screen Side View Isometric

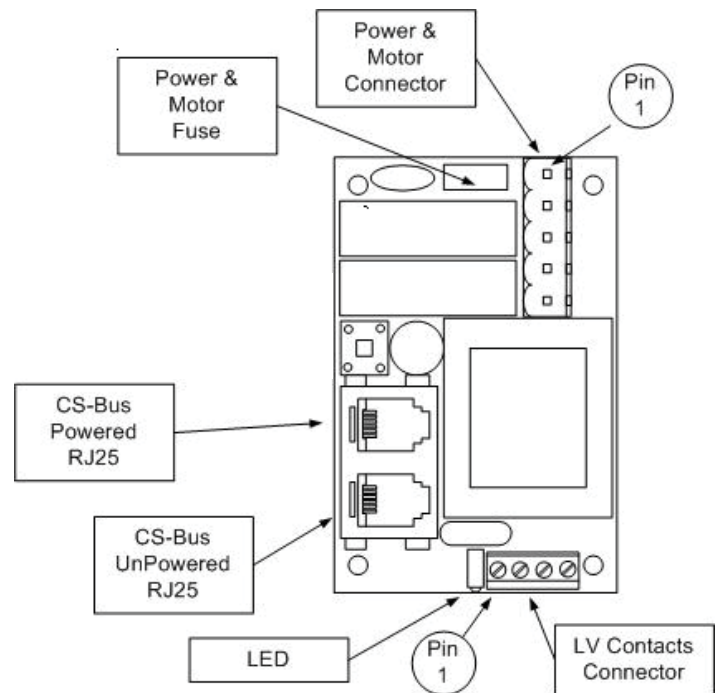

Figure 8: Cima-Link Controller (face)

Note: The Cima-Link Controller is installed at the factory when ordered with a screen. In the event of an aftermarket installation, contact the factory for instructions for mounting the controller. Call Toll-Free 800-762-4999 or 310-784-5300.

OPTIONAL CONTROL - CIMA-LINK INFRARED PACKAGE CONNECTION

MAKING THE CONNECTION

1. Connect the RJ25 cable to the top RJ25 jack located on the left side of the Cima unit.
2. Place infrared eye in line of sight of remote.

Note: The maximum length of the RJ25 cable shall not exceed 50'.

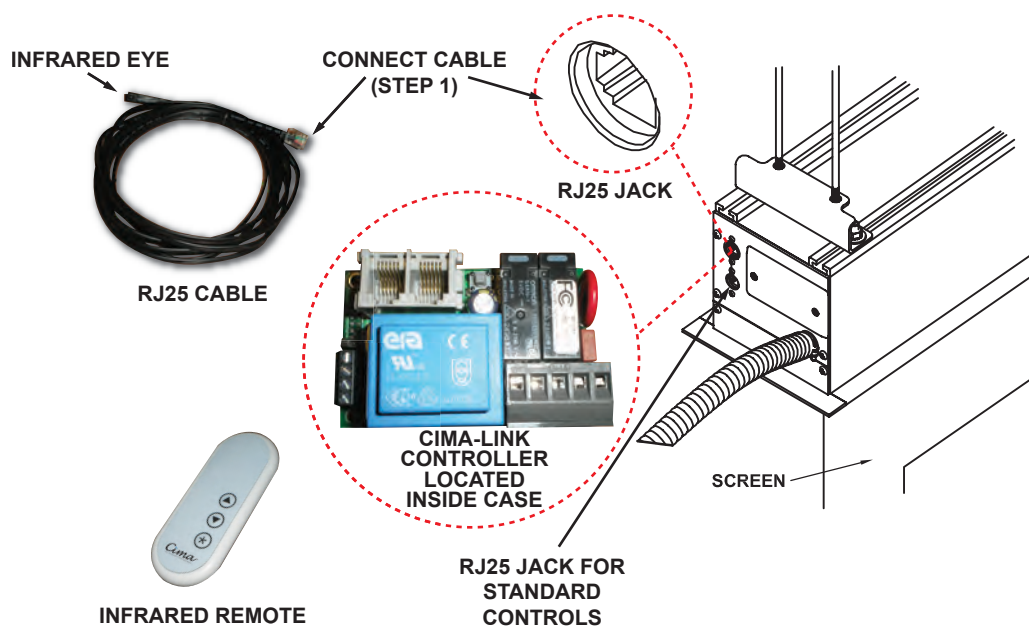

Figure 9: Cima-Link Infrared Package Connection

OPTIONAL CONTROL - CIMA-LINK ETHERNET PACKAGE CONNECTION

MAKING THE CONNECTION

1. Connect the RJ25 cable to the left RJ25 jack located on the left side of the Cima unit.
2. Place the other end of the RJ25 cable to the RJ25 jack in the IP device.
3. Place the RJ45 cable in the RJ45 jack in the IP Device.
4. Place the other end of the RJ45 cable in the end-user device.

Note: The maximum length of the RJ25 cable shall not exceed 50'.

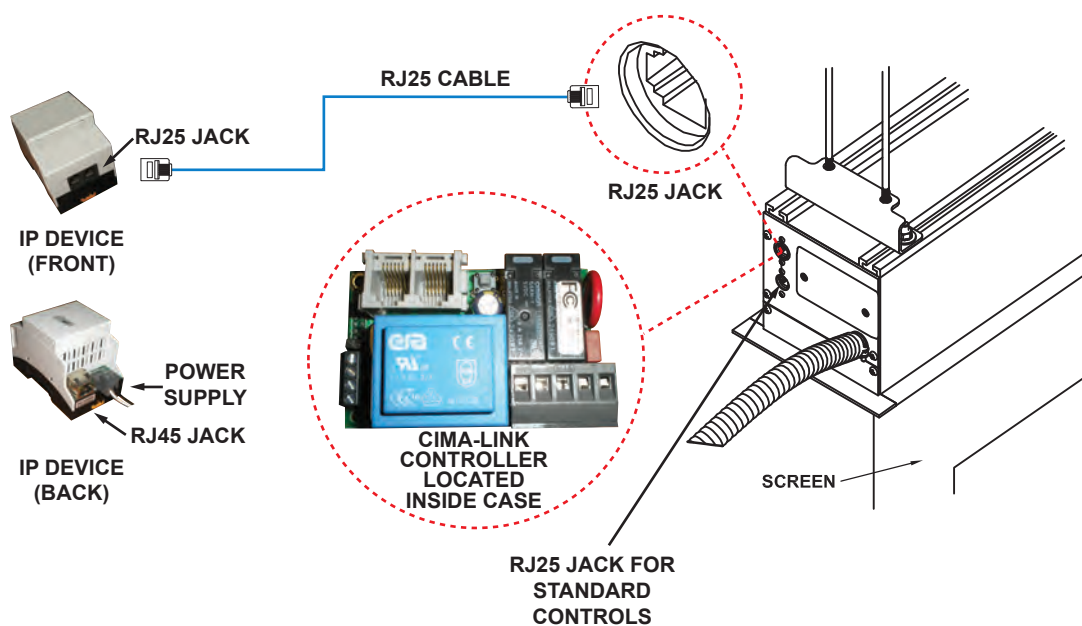

Figure 10: Cima-Link Ethernet Package Connection

OPTIONAL CONTROL - CIMA-LINK RS232 PACKAGE CONNECTION

MAKING THE CONNECTION

1. Connect the RJ25 cable to the top RJ25 jack located on the left side of the Cima unit.
2. Place the other end of the RJ25 cable to the RJ25 jack in the RS232.
3. Connect the 9-pin end of the RS232 to the 9-pin jack in the end-user device.

Note: The maximum length of the RJ25 cable shall not exceed 50'.

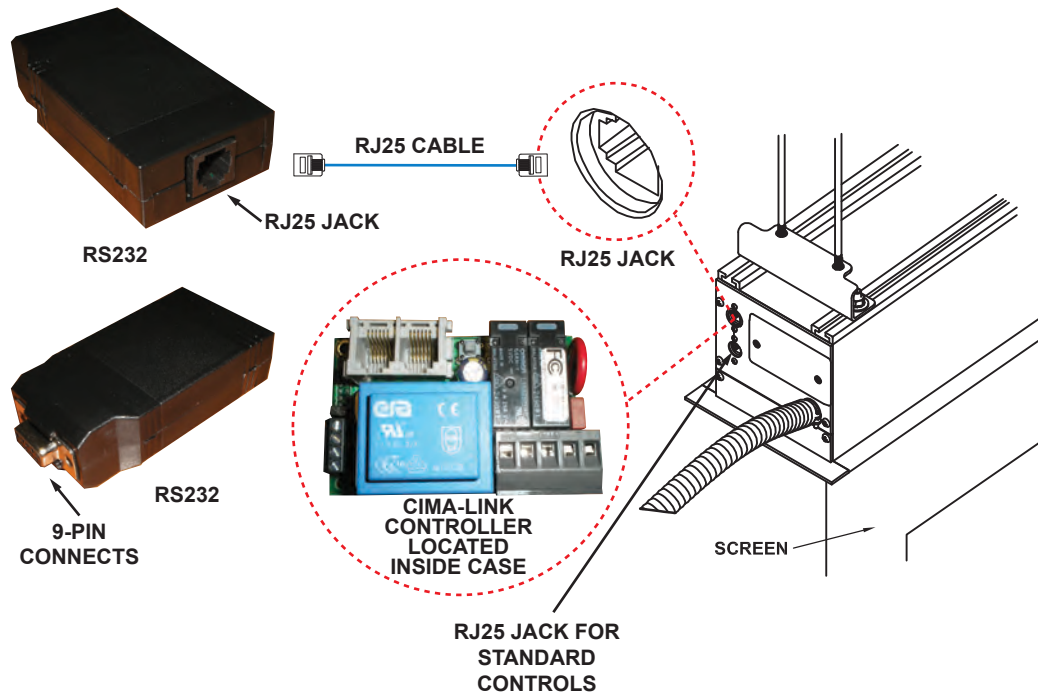

Figure 11: Cima-Link RS232 Package Connection

Note: For RS-485 connection protocol, installer may need to provide an adapter to interface with the control system. This adapter is not included.

OPERATING THE SCREEN

DESCRIPTION

The method you use to raise and lower the screen depends on the type of switch control device you have selected.

When you lower or retract the screen, it will stop at its preset limit. If an obstacle (such as a person or furniture) is in the path of the screen as it is lowered, use the switch control to stop the screen's motion (it will not automatically stop if it hits an obstacle).

The motor is designed to be used for short operations such as lowering the screen in preparation for viewing. The motor is not designed for continuous duty. If the motor operates continually for more than a few minutes, it may automatically shut off to prevent damage from overheating. If the motor occasionally needs to be run more than normal, for example during initial setup and positioning, allow time for the motor to cool down.

In general, when the screen is not in use, you should store it in the fully retracted position.

⚠ CAUTION

Do not operate the motor when any of the following occurs:

- ▶ The unit emits any smoke, heat, abnormal noise or unusual odor.
- ▶ The unit is damaged in some way, such as damage from a water leak.

If any of these situations occurs, call a qualified service person.

SWITCH & TRIGGER WIRING

The 3-button, low-voltage keypad operates with only 3 conductors; common, up & down. The "Stop" function shorts both directions internally to common. You can use both switching functions simultaneously by simply connecting a splitter to the Cima RJ Input jack. The trigger input is only a 2 conductor connection.

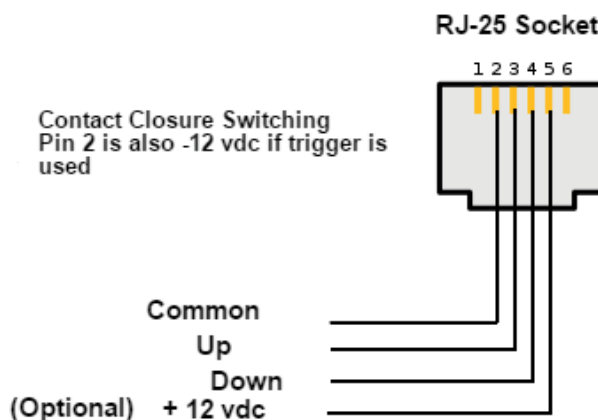

Figure 12: Pinout Diagram

ADJUSTING THE SCREEN EXTENSION

⚠ CAUTION

Improper adjustment of the limit switches can cause irreparable damage to the screen itself, resulting in voiding the factory warranty.

The extension and retraction limit switches have been preset at the factory. In general, we advise you to avoid readjusting these switches. In some cases, to enable proper alignment of the displayed image on the screen, you may need to adjust the extension of the screen. If adjustment to the extension is necessary, carefully follow these instructions.

WARNING!

The screen is fully retracted when the batten is flush with the bottom of the case. Do not attempt adjustments with the yellow retraction (UP) limit switch that will further retract the screen. Incorrect adjustment of the switch will cause severe screen damage. Please consult the factory if you have any questions.

ADJUSTING THE SCREEN EXTENSION

The standard preset black drop is 6"; this should not be reduced less than 2" of black drop visible. Please refer to your specifications on your maximum black drop allowed.

WARNING!

Do not attempt to modify the screen extension beyond these recommended amounts. There is a line printed on the screen material that warns you where not to exceed the black drop. Going beyond this line could result in damage to the screen.

To increase the screen's fully extended (screen down) stop position:

1. Lower the screen to its current stop position.
2. Remove the dust cover to locate the white extension (down) limit switch on the left side of the screen tube (audience left). Use a small electrician's style screwdriver or a 5/32" (.4 cm) hex wrench to turn the switch in a counterclockwise direction. If the power is still on, the screen will drop incrementally as the switch is turned.

Note: One complete turn of the switch will make approximately a 3/4" (2 cm) change in the screen's stop position.

ADJUSTING THE SCREEN EXTENSION (CONTINUED)

To decrease the screen extension:

1. Lower the screen until it is extended about halfway down.
2. Remove the dust cover to locate the white extension (down) limit switch on the left side of the screen tube (audience left). Use a small electrician's style screwdriver or a 5/32" (.4 cm) hex wrench to turn the switch in a clockwise direction.

Note: One complete turn of the switch will make approximately a 3/4" (2 cm) change in the screen's stop position.

3. Activate the screen in the down direction until it reaches the newly reduced stop position. Repeat this procedure until the desired stop position is reached.

Once you have made the adjustment, whenever you lower the screen, it will automatically stop at the new position.

Note: The yellow "UP" limit switch is to stop the motor in the retracted position. We advise not adjusting this switch as to avoid possible screen damage should the switch get mis-adjusted. It is recommended that you make a note of any changes made to the factory preset.

SCREEN CARE AND CLEANING

With reasonable care, you may expect many years of dependable use of your Stewart projection screen. We encourage you to keep your screen clean. To protect your screen when it is not in use, store it in the fully retracted position. Avoid getting any foreign material on the screen, as cleaning may prove very difficult. It may not be possible to remove scratches, paint, ink, etc.

GENERAL MAINTENANCE

Treat your screen surface delicately. Special attention to these instructions should be followed when cleaning.

- ▶ A draftsman-style brush may be used to lightly whisk away any loose dirt or dust particles. (This type of brush is usually available at office supply stores.) Stewart Filmscreen has an optional screen cleaning kit that contains the proper type of brush. Contact your dealer if you would like to obtain this cleaning kit.
- ▶ Particles left on the screen when it is retracted into the case may form an impression on the screen surface. Periodically wipe the back of the screen with a clean damp cloth.
- ▶ For tougher spots, you can make a cleaning solution using a water-based detergent and warm water. To make the solution, mix one part Simple Green, 409, or other water based industrial cleaner with three parts warm water. Moisten a clean cotton cloth or Q-Tip with this solution, moisten the stained area, and gently lift off the stain. Never use an aggressive scrubbing action as you could damage the screen surface by removing the optical coating. Remoisten the area with clean water and dab dry with a clean sponge or cotton cloth. Any residual watermarks will evaporate on their own in a few minutes.

Do not use any other cleaning materials on the screen. Contact the factory if you have questions about removing difficult spots.

WEEKLY MAINTENANCE

To maximize the longevity of your Cima screen we recommend the screen be deployed overnight at least once a week.

If using a 3rd party control system to deploy your Cima screen, you may be able to program the 3rd party system to automatically deploy your Cima screen once a week.

REPLACEMENT PARTS & SERVICE

No user-serviceable parts are contained within the unit. Contact your dealer or the factory if you require part replacement or service.

TROUBLESHOOTING

Refer to the following guidelines if you encounter a difficulty in the operation of your Stewart Filmscreen product. Problems related to electrical or motor function may require a qualified service person or electrician. Should you have a problem that is not addressed here, call Stewart Filmscreen Corporation (310-784-5300) Toll free (800-762-4999).

Problem	Cause	Action Steps
Screen won't operate.	No AC power available. Outboard switching problem.	Check to see if the circuit breaker has switched off. Reset if needed. Check outboard switching apparatus. Check voltage availability. Contact an electrician.
Screen won't roll up or down (even though power is available).	Bad connection at switch. Polarity of IMC / STI line may be bad.	Have an electrician or qualified service person check the connection as follows: <ul style="list-style-type: none"> ▶ If you have a low voltage control unit, check the switchline connections. ▶ Check STI / IMC module's line connections, or the miniplugs at the screen input or projector output. Check 12V DC line for correct polarity. Contacts may be sticking. Tap relay to free contacts.
Screen roller chatters when power is activated.	Can be caused by voltage drop, bad connections, or a defective switch.	Have an electrician or qualified service person check all hookups including all outboard wiring.
Unit hums in up mode. (Screen has already retracted.)	The screen batten is retracting too far into the case. Failure to correct can damage motor and screen. Do not use the unit until this problem is resolved.	Have a qualified service person adjust the yellow UP limit switch.
Screen drops when up direction is activated (grinding noise occurs).	Drop in voltage.	Screen motor requires full voltage. Have an electrician or qualified service person check available voltage.

TROUBLESHOOTING

Problem	Cause	Action Steps
Screen continues past bottom stop position.	White limit switch is out of adjustment.	Readjust the white DOWN limit switch. See the section on Adjusting the Screen Extension.
Batten retracts too far into case.	Yellow limit switch is out of adjustment. Failure to correct can damage motor and screen. Do not use the unit until this problem is resolved.	Have a qualified service person readjust the yellow UP limit switch.
Motor shuts off. Motor has been in use for more than 2 minutes.	Motor is designed for short operations (lowering and retracting), not continuous duty. Longer operation, causes the motor to overheat and shut off.	Allow the motor to cool down. Complete cooling can take an hour or more. Heat gain is cumulative and takes time to dissipate. If motor use is initiated before it has cooled completely, the motor will shut down again when it reaches maximum temperature.
Dirt, fingerprints, marks, etc. on screen surface.	Improper handling of screen.	Lightly brush off or use a mild detergent solution with a clean rag or cotton swab.
Indentations appear on screen surface.	Debris or particles adhering to screen due to static cling.	Check back of screen; gently brush debris away with a draftsman-style brush.

LIMITED ONE YEAR WARRANTY

STEWART FILMSCREEN CORPORATION (Stewart) warrants all products to the original purchaser only. Stewart products are guaranteed to be free from defects in materials and workmanship for a period of one (1) year from the date of purchase by the original purchaser or eighteen (18) months from date of manufacture, as defined in the serial number. Additionally, all products must be properly operated and maintained according to Stewart instructions and cannot be damaged due to improper handling or treatment after shipment from the factory. This warranty does not apply to equipment showing evidence of misuse, abuse, or accidental damage, including neglect caused by improper installation (i.e. proximity to hot lights, exposure to extreme heat or cold, exposure to excessive humidity, etc.)

Stewart on-site warranty repair services are not available for this product. Stewart's sole obligation under this warranty shall be to repair or to replace (at Stewart's sole discretion) the defective part of the merchandise. This warranty expressly does not cover any costs of removal, installation, framing, or other costs incidental to replacing the screen or returning it to Stewart. Returns for service should be made to your Stewart dealer. If it is necessary for the dealer to return the screen or part to Stewart, transportation (freight) expenses to and from Stewart are payable by the purchaser. Stewart is not responsible for damage in shipment. To protect against damage or loss in transit, insure the product and prepay all transportation expenses.

This warranty is in lieu of all other warranties, expressed or implied, including warranties as to fitness for use or merchantability. Any implied warranties of fitness for use, or merchantability, that may be mandated by statute or rule of law are limited to the one (1) year warranty period. This warranty gives you specific legal rights, and you may also have other rights which vary from state to state. In no event will Stewart be liable for sums in excess of the purchase price of the product. No liability is assumed by Stewart for expenses or damages resulting from interruption in operation of equipment, or for incidental, direct, or consequential damages of any nature. In the event that there is a defect in materials or workmanship of a Stewart Filmscreen product, you may contact our Customer Service Department at 1161 W Sepulveda Blvd, Torrance, California 90502- 2797 (310-784-5300) Toll free (800-762-4999).

IMPORTANT: This warranty shall not be valid and Stewart shall not be bound by this warranty if the product is not operated and maintained in accordance with Stewart's written instructions. Stewart Filmscreen Corporation shall not be liable for any and all consequential damage(s) occasioned by the breach of any written or implied warranty pertaining to the sale of a Stewart Filmscreen product in excess of the purchase price of the product sold.

xxx



The Reference for Stunning™

www.stewartfilmscreen.com

1161 W. Sepulveda Blvd., Torrance CA 90502 USA | 800.762.4999 | Tel: 310.784.5300 | Fax: 310.326.6870 | Email: request@stewartfilmscreen.com

©2020 Stewart Filmscreen. Specifications are subject to change without notice.