

# Luxus

Retractable, Below Ceiling Screen System

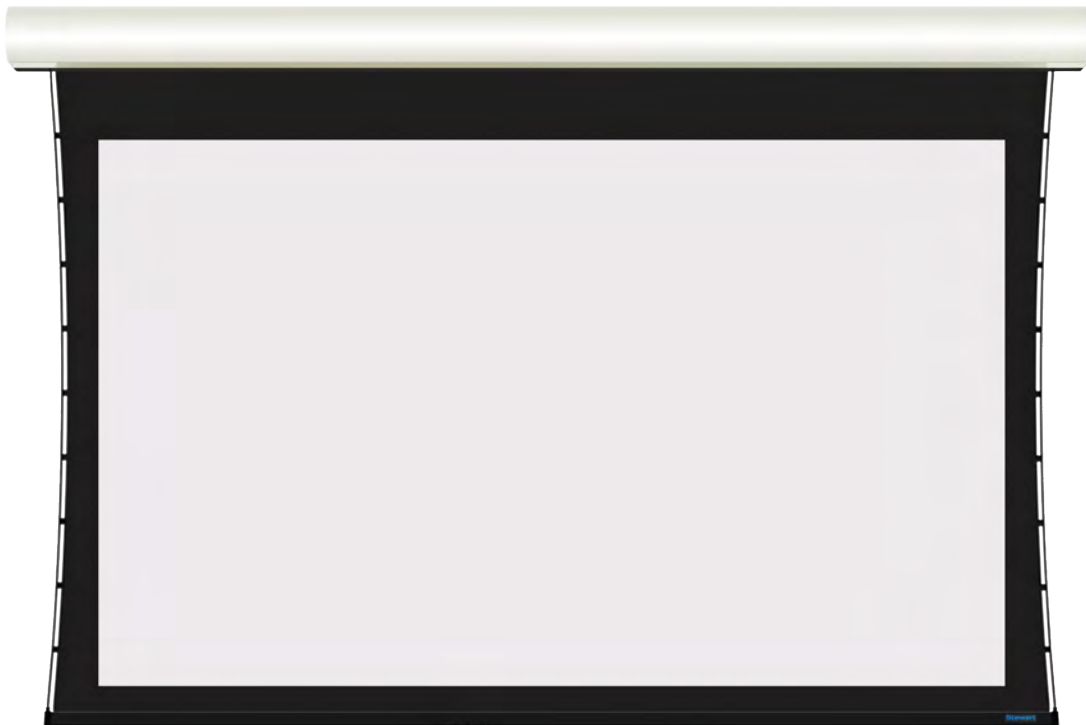

Printed in U.S.A. ©2025 Stewart Filmscreen Corporation

Stewart Filmscreen reserves the right to make changes to the product specified in this document. Sizes and specifications subject to change without notice at Manufacturer's discretion. From time to time, this document is updated. Current versions of documentation are posted on the Stewart Filmscreen website at:

**[www.stewartfilmscreen.com](http://www.stewartfilmscreen.com)**

# Luxus

## OWNERS MANUAL

### Contents

To the Owner . . . . .	4
About Luxus . . . . .	5
Preparing the Installation . . . . .	6
Wall Mount. . . . .	9
Ceiling Mount. . . . .	11
Overall Dimensions . . . . .	13
Electrical . . . . .	15
IMC with IR Receiver and Remote (Standard) . . . . .	16
12 Volt Projector Trigger (Standard). . . . .	18
RTS Motor Operation (If Equipped) . . . . .	19
IR Wall Switch and Remote (If Equipped). . . . .	20
Decora Paddle Wall Switch (If Equipped) . . . . .	21
IBT-100 for Serial (RS-232C) Connectivity (If Equipped) . . . . .	22
Operating the Screen. . . . .	23
Intelligent Motor Control (IMC) Wiring . . . . .	24
IMC RJ45 Pinouts Found on the Back of Case . . . . .	26
IMC Specifications . . . . .	27
Limit Switch Adjustment . . . . .	28
Adjusting the Screen Tension . . . . .	30
Fascia Removal . . . . .	31
Caring for and Cleaning the Screen . . . . .	32
Troubleshooting . . . . .	33
One (1) Year Limited Warranty . . . . .	35

## TO THE OWNER

---

Congratulations on purchasing the finest optical viewing screen in the world.

Your handcrafted Luxus projection screen has been carefully inspected to ensure your optimal viewing experience will last for many years. Please take a moment to review this manual. It will guide you through the installation and the operation of your screen and will also provide you with detailed instructions on how to care for your screen's viewing surface.

From all of us at Stewart Filmscreen, we would like to thank you for choosing Luxus. Should you have any questions, please don't hesitate to contact our customer service department at 1 (310) 784-5300, or toll free at 1 (800) 762-4999. We're here to help.

Jose Garcia | Small Electric Screen Craftsman

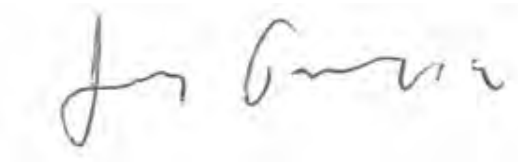
A handwritten signature in black ink, appearing to read "Jose Garcia". The signature is written in a cursive style and is centered on the page.

# ABOUT LUXUS

---

The next generation of Stewart Filmscreen's Luxus offers a premium below ceiling viewing experience. The newly redesigned case allows the screen to deploy close to the wall or safely in front of your wall décor. With the combination of your choice of control and mounting options and with Stewart's world-renowned premium screen materials, this screen is one of our most popular selling screens.

## **⚠ NOTE**

This owner's manual may describe options and features not equipped to the specific screen you have purchased.

## **IMPORTANT SAFETY INFORMATION**

- ▶ Carefully read the instructions appropriate for your needs.
- ▶ This screen must be installed by a qualified electrician.
- ▶ For supply connections, use wires rated for at least 75 C.
- ▶ Use copper or aluminum conductors.
- ▶ For indoor use only.
- ▶ Do not connect low-voltage to line-voltage power.
- ▶ Earth ground terminal connection must be made as shown in wiring diagrams.
- ▶ Proper short-circuit and overload protection must be provided at the circuit breaker distribution panel. You can use up to a 20 amp maximum circuit breaker with adequate short-circuit breaking capacity for your installation.

## **▶ USING THIS MANUAL FOR INSTALLATION**

If you are using this manual to install the Luxus screen, you should be aware that it describes procedures for two types of mounting options. You must refer to the section for the type of mounting system you are utilizing.

For the instructions related to your specific mount type, refer to the appropriate page:

Wall Mount (Page 9)  
Ceiling Mount (Page 11)

For the instructions related to your specific controls, refer to the appropriate page:

- IR remote and receiver (Page 16)
- 12 volt projector trigger (Page 18)
- RTS with remote (Page 19)
- IR wall switch and receiver (Page 20)
- Decora paddle wall switch (Page 21)
- IBT-100 for RS-232C interface (Page 22)

# PREPARING THE INSTALLATION

---

Before proceeding with the installation of this screen, take time to thoroughly read and understand these installation instructions. Failure to comply with the instructions contained in this manual may result in **voiding your warranty**.

## SPECIFICATIONS

Specifications regarding the individual screen dimensions, weight, etc., are provided by the factory when the unit is ordered.

Before beginning the installation

- Check the size and weight of the screen to be installed so that you can plan for the number of people required for installation.
- You will need at least two people to mount the smaller screens. More are needed for larger, heavier screens.

## What's inside the box?

Inside your Luxus unit box, you will find everything needed to get started enjoying your Stewart screen:

- Luxus unit preassembled and prewired
- Two ceiling or wall mounts to be used in whichever configuration is preferred
- Packing material
- IR remote and IR receiver (standard control)
- Two RJ45 male connectors and two 3.5 mm male connectors
- Luxus Quick Start Guide

## You will need

- A level
- A drill
- A drop cloth
- Tools for tightening fasteners
- Ladders for the personnel supporting the screen during the mounting process
- Fasteners appropriate for the surface on which the screen is being mounted
- We suggest a self-leveling laser due to the dual mounting of the wall or ceiling mounts. Both mounts will need to be accurately leveled to each other.

## PREPARING THE INSTALLATION (CONTINUED)

Note: Bolts and other fasteners for the screen are standard gauges and sizes used in the U.S., regardless of the installation country. For this reason, sizes are expressed in inches rather than metric measurements.

### ⚠ CAUTION

Do not stand on the screen case or store it on its end. This will cause screen damage. If you are not going to install the screen immediately, make sure it remains horizontal during storage. Note: Failure to comply with the instructions and guidance contained in this manual may result in voiding your warranty.

### Unpacking

Be sure to unpack carefully in a clean area. Use special care when handling the screen so that it does not become soiled or damaged. If you plan to repack your screen and hardware for transportation to another location, you may want to photograph or make a note of how it was packed. Retain the packing material for future use, if desired.

The Luxus screen may have special retainers for the batten and roller tube. These items may be left in place until after the screen has been mounted (see Figure 1).

**IMPORTANT:** Remove all batten retainers prior to activating the unit. Failure to do so will cause damage to the screen material. There will be one batten retainer on each end of the unit. Larger units come with an additional batten retainer on the middle of the unit. A single screw holds each batten retainer in place (see Figure 2).

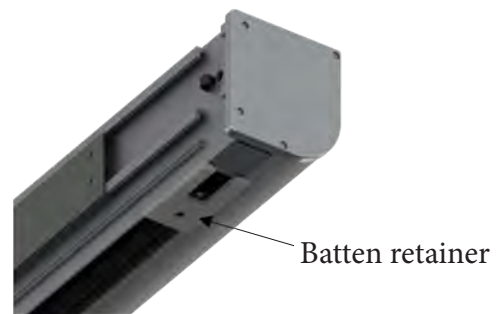
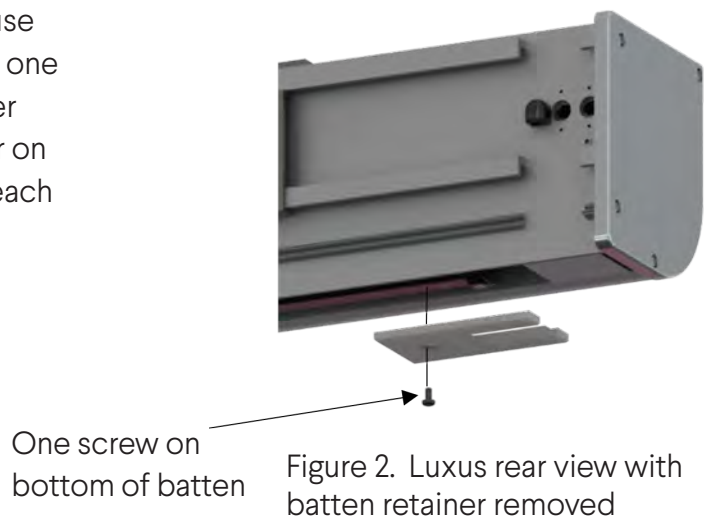

Figure 1. Luxus bottom view with batten retainer installed



## PREPARING THE INSTALLATION (CONTINUED)

When installing your Luxus to the wall or ceiling using the sliding mount bracket, there are a couple things to consider to make the installation a smooth and easy operation.

### Mounts



Figure 3. Top of Luxus mount

Inside each Luxus box there are two 18 inch mounts to be used in whichever configuration that is required. Each mount has a total of six holes pre-cut to ensure that at least two studs are utilized for mounting (see Figure 3). The spacing between the two edge holes is 16 inches.

### Fasteners

The type of fasteners used for mounting is critical. If incorrect fasteners are used, the channels of the Luxus may not latch onto the mount clips. Additionally, if weak fasteners are used, the Luxus unit may fall. Be sure to use a total of four No. 10, 3 1/2 inch deck screws on each mount (see Figure 4).

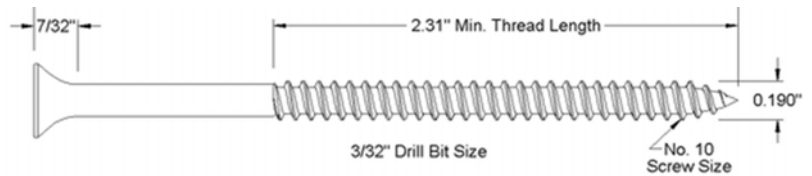

Figure 4. No. 3 1/2 inch screw

### ⚠ CAUTION

The mounts included for your Luxus unit are able to be used for ceiling mount and wall mount applications. In order to ensure that the unit is level and that it sits correctly on the mount, please use a laser guided level. This is imperative to mounting the unit correctly.



# WALL MOUNT

Professional mounting techniques should be used. Stewart Filmscreen cannot be liable for substandard or faulty installations. **Failure to comply with the instructions and guidance contained in this manual may result in voiding your warranty.**

## ⚠ CAUTION

Be careful not to touch or scratch the viewing surface.

Ensure wall surface is level and free of undulations. Use shimming if necessary.

1. Identify the location of wall studs where you can secure the wall mounts.
2. Use a level to accurately position the wall mounts on the wall (see Figure 5), and make certain that both wall mounts are within 24 inches from either edge of the case. This will prevent the case from tilting to either side.
3. Drill holes through the wall mounts into the studs.
4. Use 3 ½" screws to secure the wall mounts to the wall studs.

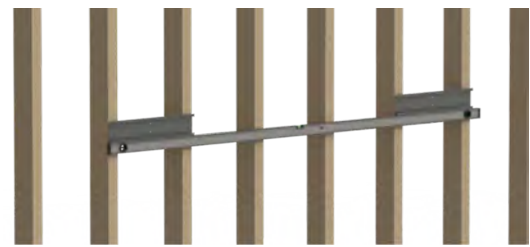

Figure 5. Wall mounts leveled and attached to one or more wall studs

- Note:** These are heavy units. Wall mounts must be mounted to as many studs as possible (see Figure 5).
5. Check to make sure the wall mount is level.
  6. Carefully lift and hook the channels on the back of the housing onto the wall mounts (see Figure 6).
  7. Ensure the housing channels are securely placed onto the hanging bar (see Figure 7).
  8. For the minimum clearance dimensions, (see figure 8).



Figure 6. Luxus case

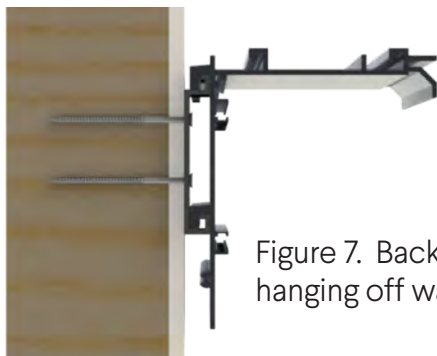

Figure 7. Back part of case hanging off wall mount

# WALL MOUNT (CONTINUED)

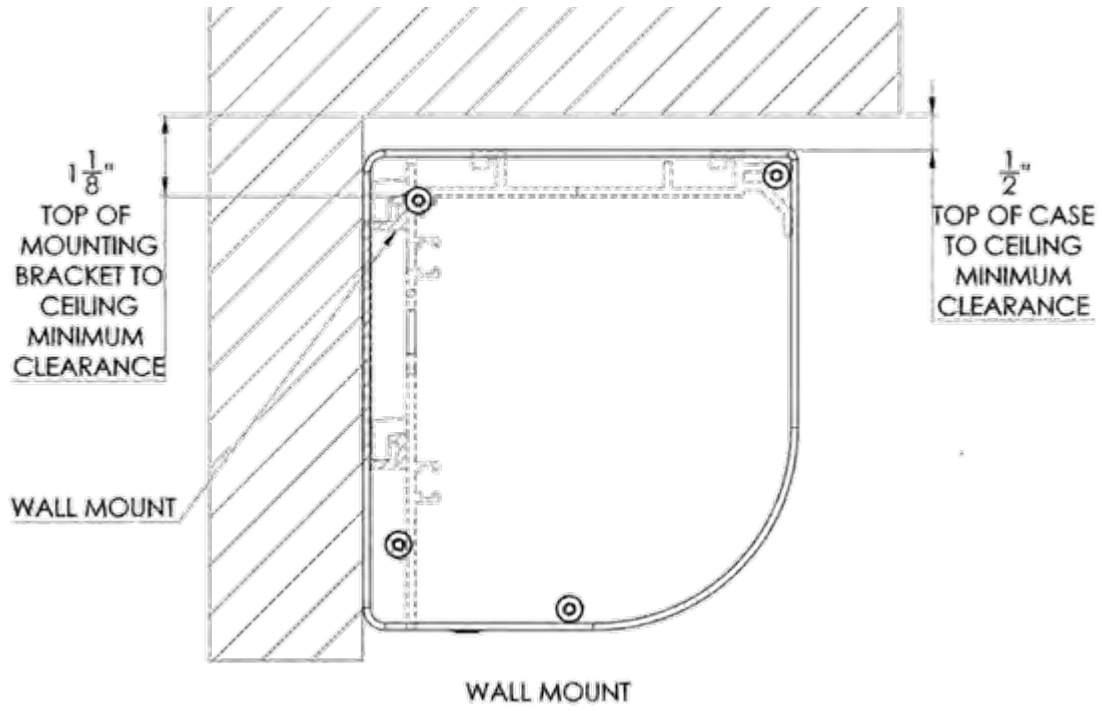

Figure 8. Wall mount detail with minimum clearance

## CEILING MOUNT

Professional mounting techniques should be used. Stewart Filmscreen cannot be liable for substandard or faulty installations. **Failure to comply with the instructions and guidance contained in this manual may result in voiding the warranty.**

### ⚠ CAUTION

During installation, do not place the unit on an unstable cart, stand, table or ladder. The unit may fall, causing injury to you or others as well as cause possible damage to the unit.

Do not mount to drywall only. There must be wood joists behind the drywall to secure the screen.

1. Use a magnetic stud finder, or similar appropriate means, to identify the location of solid ceiling joists. If the joists or rafters are parallel to the screen case, blocking is required between structural elements.
2. Use a laser guided level to properly align both ceiling mounts as straight as possible. If using traditional levels, the unit may not sit properly on mounts.
3. Screws must be mounted into solid wood. If no joists are available then the ceiling must be blocked.
4. Screw the ceiling brackets into the joists (see Figure 9). Ensure the screws are mounted to solid wood and that both ceiling brackets are properly aligned to each other.
5. Lift the case up to the ceiling and into the mounting brackets. Gently slide case backwards about 1/2" to engage and lock into brackets (see Figure 10).
6. Since both mounts do not need to be equidistant to the sides of the case, you can float the case left and right to find the perfect position even after the screen is mounted.
7. For the minimum clearance dimensions for both ceiling mount and soffit mount, (see Figure 11) and (see Figure 12) respectively



Figure 9. Ceiling bracket screwed onto ceiling joists

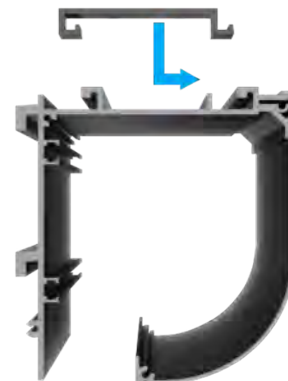

Figure 10. Luxus case extrusion with ceiling mount extrusion

# CEILING MOUNT (CONTINUED)

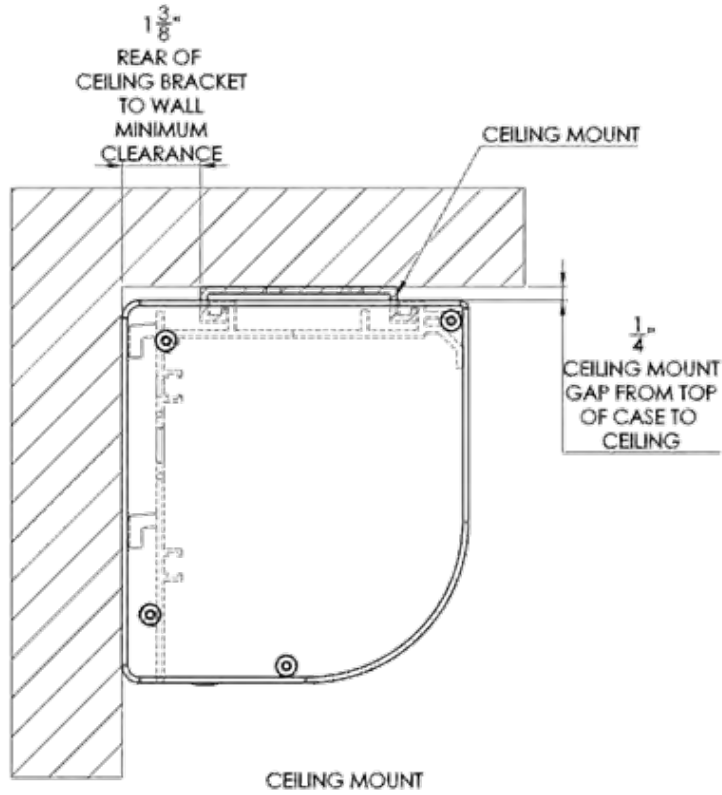

Figure 11. Ceiling mount detail with minimum clearance

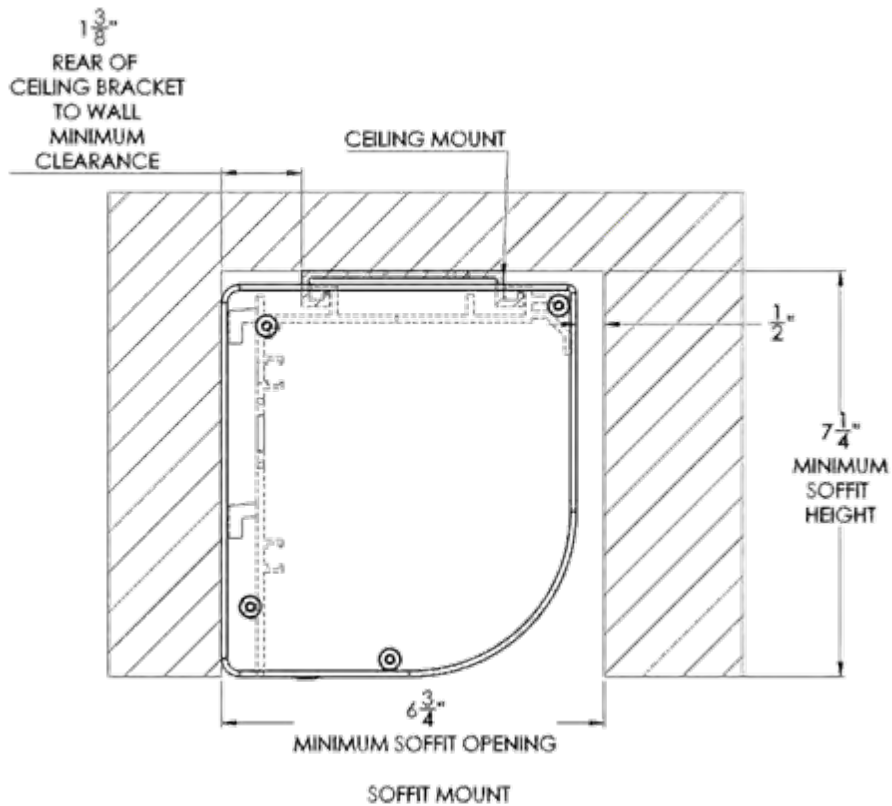

Figure 12. Soffit mount detail with minimum clearance

# OVERALL DIMENSIONS

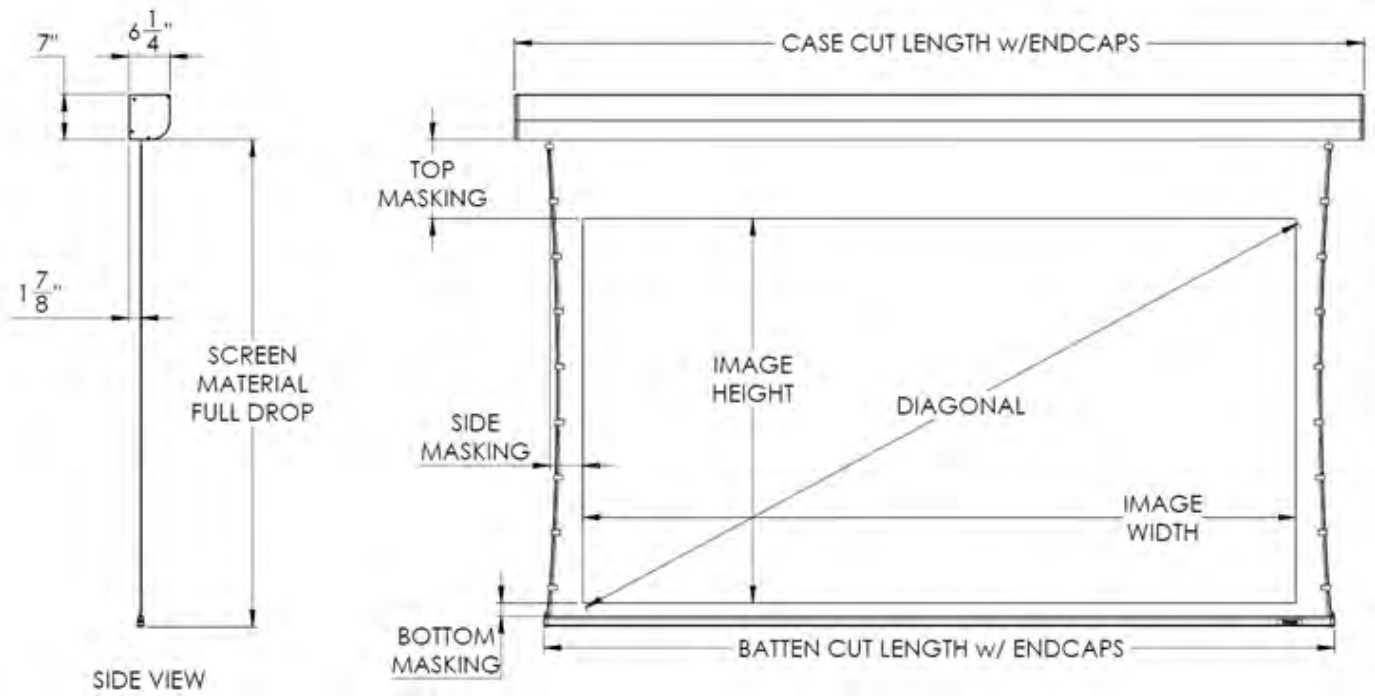

Figure 13. Front and Side view of overall dimensions

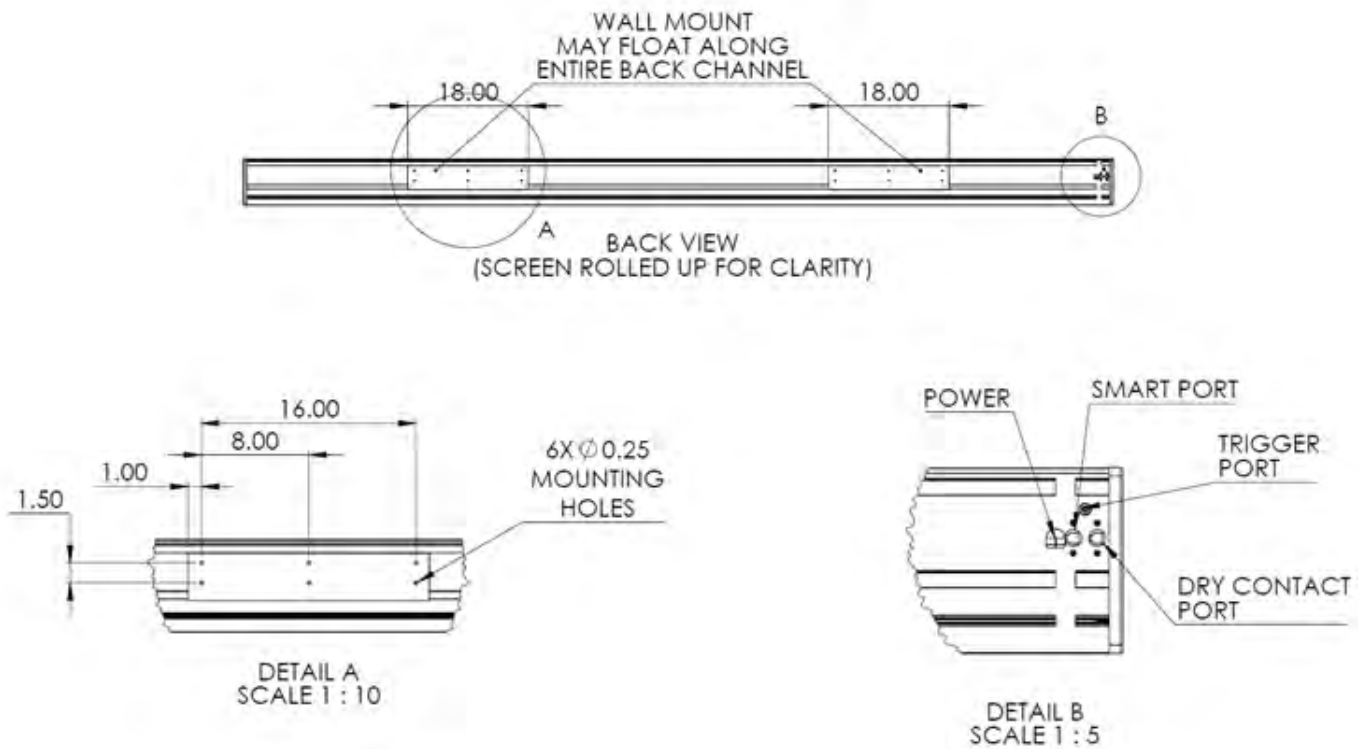

Figure 14. Rear view with detail for wall mount and control outputs

# OVERALL DIMENSIONS (CONTINUED)

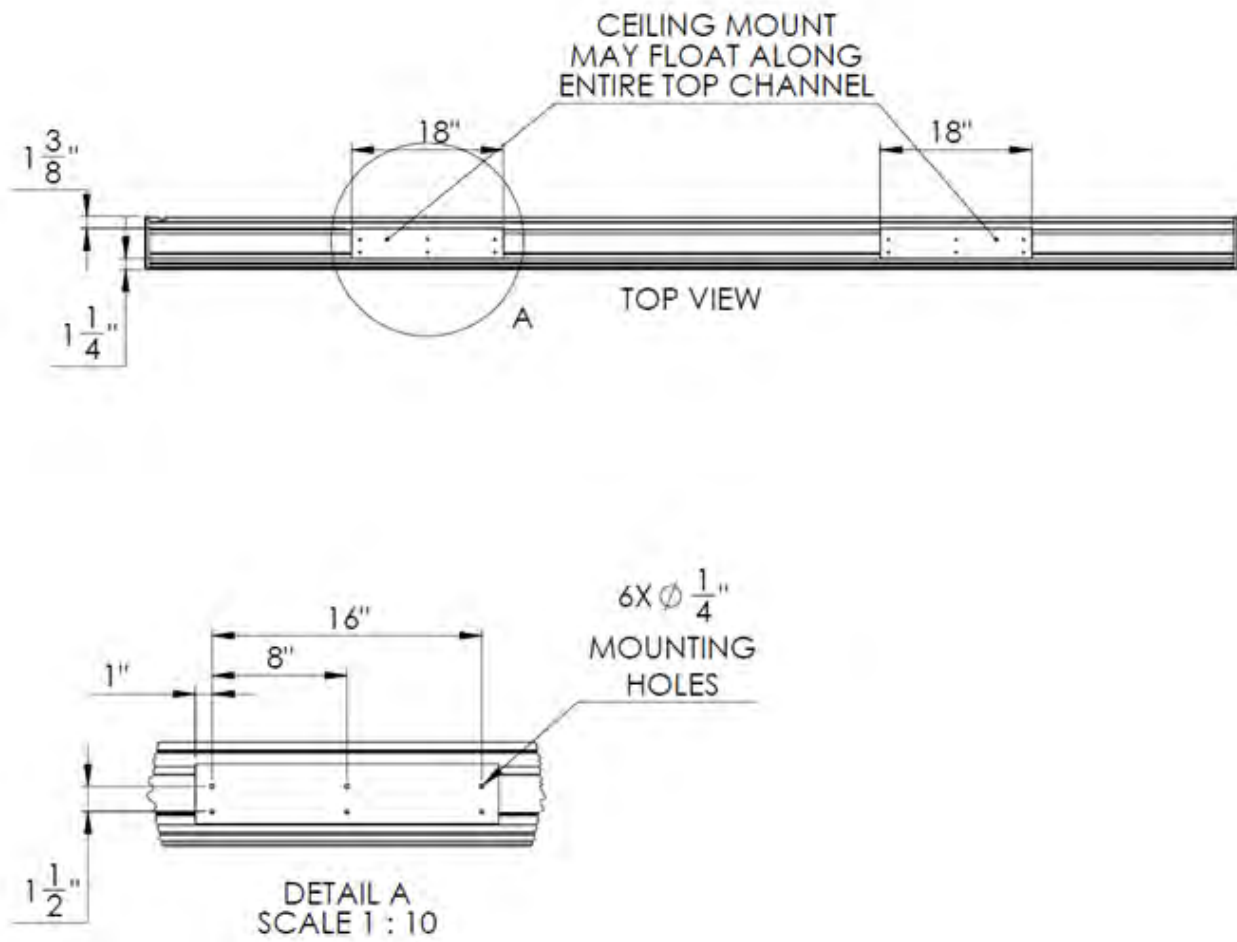

Figure 15. Top view with detail for ceiling mount

# ELECTRICAL

---

The Luxus screen system can be controlled through several remote control devices (IR and RF), keypads, dry contact outputs, internet protocol (IP), and low-voltage trigger outputs.

## **⚠ CAUTION**

Luxus is to be installed and used within the scope of the appropriate electrical codes and regulations. Failure to do so may cause malfunctioning or damage to the screen.

**Note:** This manual refers to AC (electrical alternating current) to represent electrical power. Your location may use 120 V, 220 V, or other electrical power. Screen systems are manufactured using the electrical power type specified for the location. Use appropriate power sources for your location.

## **MOTOR WIRING**

The Luxus' screen system's motor is prewired at the factory. No additional motor wiring is required.

**The following pages will outline standard and optional control types for Luxus.**

## **⚠ CAUTION**

Luxus has two female RJ45 inputs on rear of case. Neither port is to be used with POE (power over Ethernet). Improper use of ports will cause irreversible damage to IMC control board and may void your warranty.

## **Connections**

The following Stewart Filmscreen accessories that plug into the smart port have RJ45 male connections. These accessories are able to plug into the RJ45 female smart port with no issues.

- ▶ IR receiver
- ▶ IR wall switch
- ▶ IBT-100

# IMC WITH IR RECEIVER AND REMOTE (STANDARD)

A 3-button IR (infrared) remote control (see Figure 16) is supplied for the IMC (see Figure 17). The IMC control board comes ready to be operated via IR and projector trigger right out of the box. You may visit [StewartFilmscreen.com](http://StewartFilmscreen.com) for a full list of IR Hex codes if you want to program the IR to another remote.



Figure 16. IR remote



Figure 17. IMC control system

## GETTING STARTED

### Making the Connections

1. Connect the IR eye with RJ45 end to the back of Luxus on the smart port with RJ45 as shown (see Figure 18).
2. Place the IR eye anywhere in the room, making sure that there are no obstructions between the eye and the screen.

**Note:** Luxus comes with two RJ45 female inputs. The maximum length of the RJ45 cable plugged into the unit shall not exceed 50'. Dry closure modules from any home automation system can be interfaced, utilizing up/down/common type terminations only on the dry contact port.

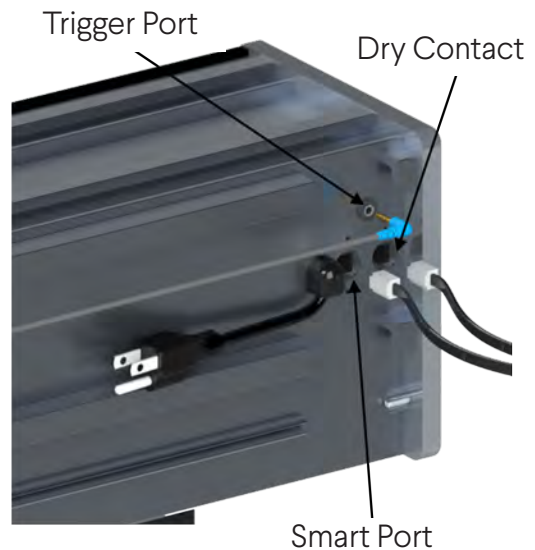

Figure 18. Rear, audience left of case with 10ft power wire, two RJ45 inputs and a 3.5mm trigger port



## IMC WITH IR RECEIVER AND REMOTE (CONTINUED)

---

### OPERATION

After the screen has been properly mounted, check that the batten retainers have all been removed. Using the IR remote, press the “down” button and the Luxus screen will automatically extend fully to its preset limit and will power itself off. Press the “up” button once and the Luxus screen will automatically retract back into the case and power itself off. If a custom position is desired, simply press the “stop” button at any time during the screen’s deployment or retraction.

**Note:** See the section, “Adjusting Screen Deployment” (see Page 28), for information regarding the default limits to which the screen can be adjusted up or down from the factory preset.

## 12 VOLT PROJECTOR TRIGGER (STANDARD)

---

Two male, mono, 3.5mm auxiliary plugs are supplied so they can be used with the standard 12 volt projector trigger feature of the IMC. Since Stewart Filmscreen cannot be certain how long of a cable will be needed for every single application, the trigger cable will have to be assembled by the installer.

### GETTING STARTED

#### Making the Connections

#### PROJECTOR TRIGGER

1. Connect the straight, male, 3.5 mm (see Figure 19) projector trigger cable to the projector. Two male pieces, straight, and 90 degrees will be supplied for the installer to make a cable.
2. Connect the 90 degree, male, 3.5 mm (see Figure 20) trigger cable to the Luxus unit's female 3.5 mm aux port (see Figure 18).
3. Make sure to properly set up your projector to send a trigger signal. The screen should automatically roll down and roll up when the projector is powered on and powered off.

#### HOW IT WORKS

When a trigger-signal equipped projector is turned on or off, voltage is either supplied or withdrawn via a class II two-conductor wire (3.5mm aux cable) connected to the screen. The projector delivers between 5 and 12 volts when it is powered.

The screen control (IMC) interprets this voltage as a prompt to deploy the screen. If there is a

sudden change in voltage, the motor is paused for  $\frac{1}{2}$  of a second before reversing direction. This is to prevent strain on the motor mechanism and to prevent damage to any material controlled by the motor. When the projector and screen are energized, the control system relay is also energized. In the retracted position, relays are automatically de-energized after 120 seconds of operation to reduce power consumption.



Figure 19. Straight 3.5mm mono plug



Figure 20. 90 degree 3.5mm mono plug

# RTS MOTOR OPERATION (IF EQUIPPED)

## RTS MOTOR

The Somfy RTS motor is an advanced option that integrates well with most home automation systems through myLink. With a network connection, Amazon Alexa, Google Home, IFTTT – or by using the myLink app with your smart device – will allow control over your Stewart electric screen’s RTS motor. Optionally, you can also purchase the RF remote to control your RTS motor.

### Programming Mode

#### Before you begin

Motors are shipped without limit settings and transmitter ID's. Steps 1 to 7 must be completed to ensure proper shade programming and functionality. Power should ONLY be connected to current shade being programmed. All other shades should be disconnected from their respective power while programming

#### STEP 1: Connect power

With the motor installed in shade, connect power to the motor (120V, or 12 V or 24V transformer or 12 V battery wand)



#### STEP 2: Initiate programming

Press both and at the same time until the shade jogs. A jog is a brief up and down motion. In Programming Mode, the shade will move only when the or is held



#### STEP 3: Check directions

Press or . When pressing product should go down or out. To change direction press and hold (Stop) until the shade jogs. A jog is a brief up and down motion.



#### STEP 4: Set the limits

Bring the shade to desired **upper** limit stop point. Press both (Stop) and until the motor moves, then release. (If the shade stops when the buttons are released take it back to the upper limit and repeat) Stop the motor when reaching the desired **lower** limit. You can adjust by pressing or



#### STEP 5: Set the limits

Press both (Stop) and at the same time until the shade moves, then release. The shade will stop at the original upper limit.



#### STEP 6: Confirm limit settings

Press and hold (stop) until the shade jogs to confirm the limit settings. A jog is a brief up and down motion.



#### STEP 7: Set user mode

Press and hold the programming button on the back of the transmitter until the shade jogs. The shade is now in User Mode. In User Mode, the shade will operate with a brief press on or Double check limit settings as a precaution.

### Adjusting the limits in User Mode



#### To change the lower limit

Send the shade to it's current lower limit.



Press both and at the same time until the shade jogs. Adjust to a new lower limit position.

Press until the shade jogs



#### To change the upper limit

Send the shade to it's current upper limit.



Press both and at the same time until the shade jogs. Adjust to a new upper limit position.

Press until the shade jogs



### Adding or deleting a Transmitter or a Channel



#### Programmed Transmitter

**STEP 1:** Using already programmed transmitters select the transmitter (single channel) or the channel, (1-5) of a multi-channel transmitter.

**STEP 2:** Press and hold the programming button of that transmitter until the shade jogs.

#### Transmitter to add or delete

**STEP 3:** Select the transmitter (single channel) or the channel, (1-5) of a multi-channel transmitter, to be added or deleted.

**STEP 4:** Press and hold the programming button of that transmitter until the shade jogs.

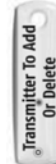

# IR WALL SWITCH AND REMOTE (IF EQUIPPED)

A 3-button IR (infrared) remote control (see Figure 16) is supplied in conjunction with the 3 button IR (infrared) wall switch (see Figure 21) for the IMC (see Figure 17). The IMC control board comes ready to be operated via IR and projector trigger right out of the box. You may visit [StewartFilmscreen.com](http://StewartFilmscreen.com) for a full list of IR Hex codes if you want to program the IR to another remote. Instead of receiving an IR receiver eye, you will get a wall switch with the eye built in.

## GETTING STARTED

### Making the Connections

1. Connect the RJ25 cable to the back of the IR wall switch (see Figure 22).
2. Connect the IR wall switch cable with RJ25 end to the back of Luxus on the smart port with RJ45 as shown (see Figure 18).
3. Install the IR wall switch anywhere in the room, making sure that there are no obstructions between the eye and the screen.
4. Keep note that you may want to hide the cable inside your wall to ensure a clean install.

**Note:** Luxus comes with two RJ45 female inputs. The maximum length of the RJ45/RJ25 cable plugged into the unit shall not exceed 50'. Dry closure modules from any home automation system can be interfaced, utilizing up/down/common type terminations only on the dry contact port.

## OPERATION

After the screen has been properly mounted, check that the batten retainers have all been removed. Using the IR remote, press the “down” button and the Luxus screen will automatically extend fully to its preset limit and will power itself off. Press the “up” button once and the Luxus screen will automatically retract back into the case and power itself off. If a custom position is desired, simply press the “stop” button at any time during the screen’s deployment or retraction.

**Note:** See the section, “Adjusting Screen Deployment” (see Page 28), for information regarding the default limits to which the screen can be adjusted up or down from the factory preset.



Figure 21. Front of IR wall switch



Figure 22. Rear of IR wall switch with RJ25 input

# DECORA PADDLE WALL SWITCH (IF EQUIPPED)

A three position momentary wall switch (see Figure 23) can be equipped with the standard IMC control. The IMC control board comes ready to be operated via the Decora paddle wall switch right out of the box.

## GETTING STARTED

### Making the Connections

1. Connect the RJ45/RJ25 cable to the back of the Luxus case on the dry contact RJ45 port (see Figure 18).
2. Cut the other end of the wire and expose the four conductors.
3. The colors of the exposed wire conductors need to match up to the decora wall switch (see Figure 24).
4. Connect your wires to the Decora wall switch (see Figure 24).
5. For RJ45 pinouts (see Figure 29).

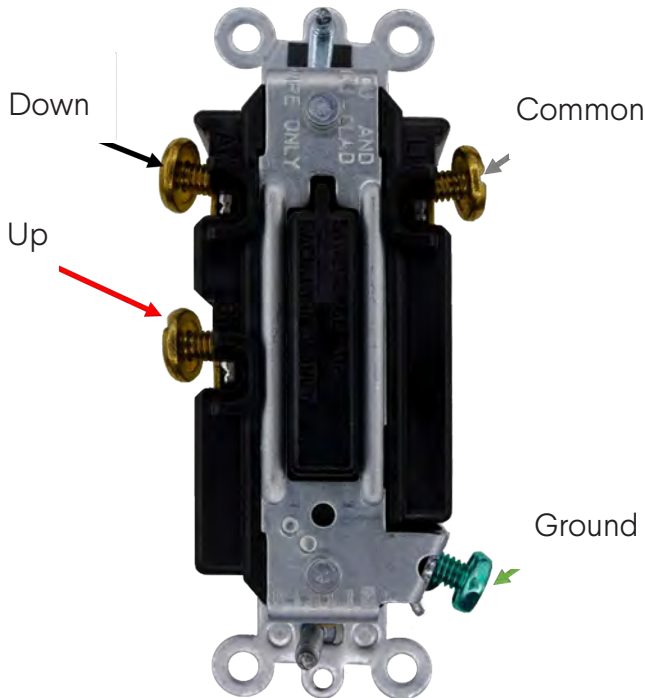

Figure 24. Rear of Decora Wall Switch



Figure 23. Front of Decora Wall Switch

Connection	Color on White
Common	White
Down	Black
UP	Red
Ground	Green

### ⚠ CAUTION

Decora wall switch is to be wired through the dry contact port only. The dry contact port is low voltage. Do not wire the wall switch through a high voltage line.

## IBT-100 FOR SERIAL (RS-232C) CONNECTIVITY (IF EQUIPPED)

---

An IBT-100 can be equipped to plug in through the smart port on the back of the Luxus case. This unique piece of hardware combined with its integrated firmware and optional ancillary software can be used to interface CS-Bus controllers with external RS-232C networks to enable seamless bi-directional control and feedback.

### GETTING STARTED

#### Making the Connections

1. Connect the RJ25 cable to the back of the Luxus case on the smart port with RJ45 (see Figure 18).
2. Connect the other side of the RJ25 cable to the RJ25 female port on the IBT-100 (see Figure 25).
3. Connect your third party RS-232C connection to the female RS-232C port on the IBT-100.



Figure 25. IBT-100, showing RJ25 port

## OPERATING THE SCREEN

---

The method you use to raise and lower the screen depends on the type of control system and motor you have installed.

### **⚠ CAUTION**

Be careful not to touch or scratch the screen's viewing surface.

**Note:** When you lower or retract the screen, it will stop at its preset limit. If an obstacle, such as a person or any furniture, is in the path of the screen as it is lowered, use the switch control to stop the screen's motion. The screen will not automatically stop if it hits an obstacle.

The motor is designed to be used for short operations such as lowering the screen in preparation for viewing. The motor is not designed for continuous duty. If the motor operates continually for more than a few minutes, it may automatically shut off to prevent damage from overheating. If the motor occasionally needs to be run more than normal, i.e., during initial setup and positioning, allow time for the motor to cool down.

In general, when the screen is not in use, you should store it in the fully retracted position to protect the screen's surface. It is best practice however, to deploy the screen for extended periods. Periodic deployment on a regular basis will maximize the flatness and uniformity of the screen's surface. The screen benefits from frequent and extended periods of deployment.

### **⚠ CAUTION**

If the unit emits any smoke, heat, abnormal noise or unusual odor, the unit is most likely damaged in some way – such as damage from a water leak or power surge. Do not operate the motor if any of these situations occur. Call a qualified service person for assistance.

# INTELLIGENT MOTOR CONTROL (IMC) WIRINGW

The IMC is a low voltage screen control that allows for switching conductors to be run in Class II (small wire, exposed, no conduit) and will interface with outboard video switching systems.

The IMC has the capability of being operated through a wall switch, infrared remote, radio frequency remote, internet protocol (IP) control system, and a screen trigger through a projector. The IMC is the most robust controller offered for Luxus. For a detailed look at what the IMC has on board, please see below (see Figure 26).

The IMC comes prewired from the factory to the motor and to the power cable. For your reference, in the case of servicing, we broke down the pin layout for the high voltage side of the connections (see Figure 27). Always have a qualified electrician handle high voltage connections.

AC load side	IMC 100	Motor Power Connection
BLACK	Pin 1	AC Line +
WHITE	Pin 2	AC Neutral
NC	Pin 3	Motor RED Line
NC	Pin 4	Motor BLACK Line
NC	Pin 5	Motor Neutral
GREEN	NC	Connect Ground to Grounding" lug on IMC housing. Also connect ground wire from motor housing to same lug

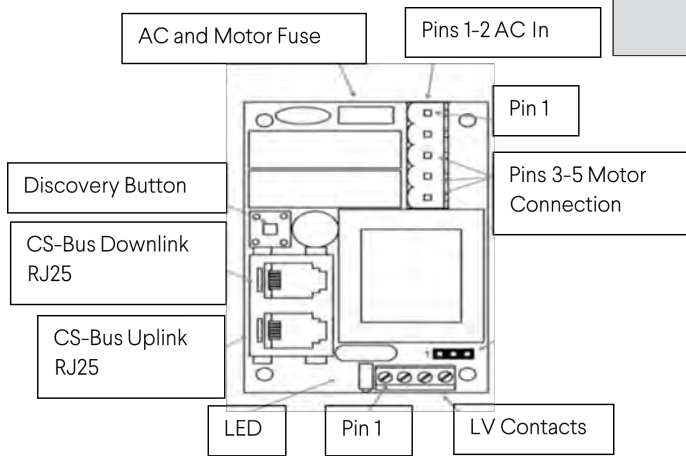

Figure 26. IMC control board schematic

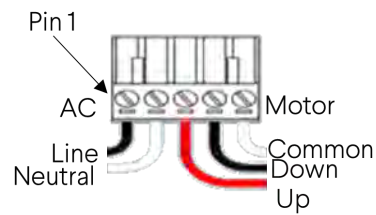

Figure 27. High voltage pin schematic

LVC Contacts	IMC 100	COMMANDS
COMMON	Pin 1	COMMON
CHANNEL 1 INPUT	Pin 2	UP
CHANNEL 2 INPUT	Pin 3	DOWN
SCREEN TRIGGER INPUT	Pin 4	TRIGGER 3-15 VDC w/ COMMON



# INTELLIGENT MOTOR CONTROL (IMC) WIRING (CONTINUED)

The IMC can be wired to any dry contact wall switch (see Figure 28). If you would like one from Stewart Filmscreen, you may order as an option directly from us.

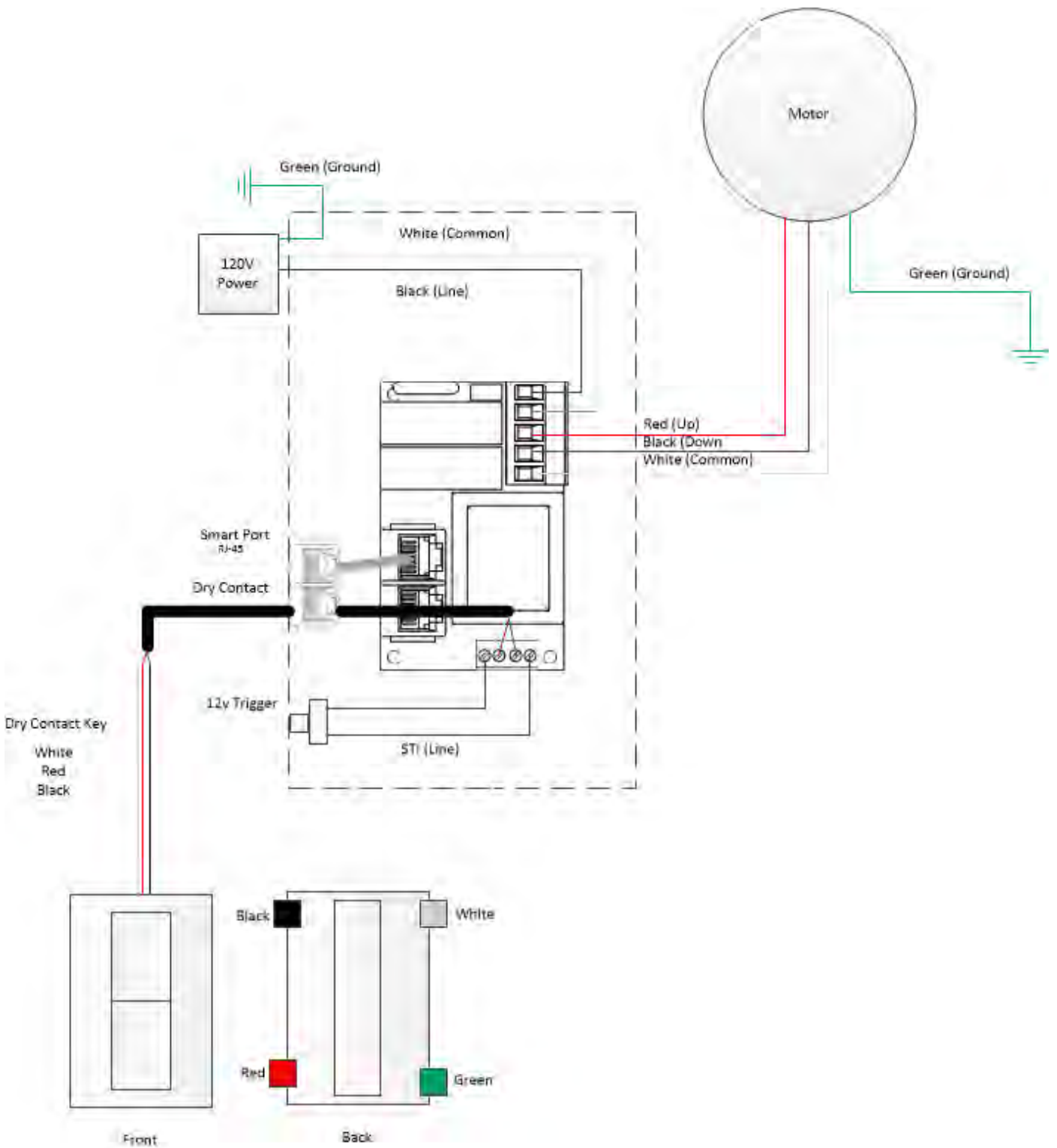

Figure 28. IMC Wiring Diagram

## IMC RJ45 PINOUTS FOUND ON BACK OF CASE

All Stewart Filmscreen “smart port accessories” that are RJ25 will plug into the RJ45 smart port (see Figure 18) on the back of the Luxus case. In the box you will find two spare RJ45 connectors. These are provided for the ease of making or extending wires for use with dry contact port. If you need to create a connection using the included RJ45 plugs, you must connect to the dry contact port (see Figure 18). Any dry contact connections must match the RJ45 pinout diagram (see Figure 29).

8 Pin RJ45 for Low Voltage Dry Contact Connector

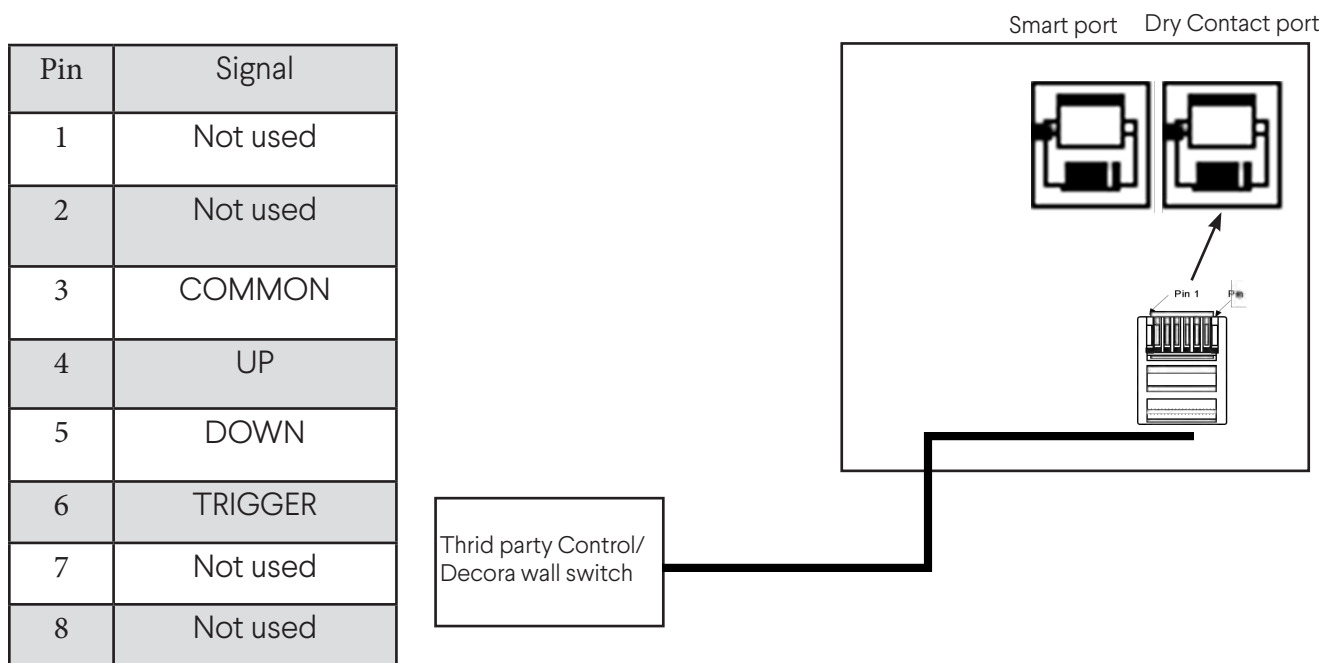

Figure 29. RJ45 pinout diagram

### ⚠ CAUTION

Do not plug in any POE (power over Ethernet) devices into either the smart port or dry contact port. Irreversible damage to the IMC board will occur and your warranty may be void.

# IMC SPECIFICATIONS

---

Network (IP) Connection	Through separate (single) e-Node
RS-232c Connection	Through separate (single) IBT-100
Compliance	ETL Listing to UL 325 , FCCA, CE, RoHS
Dimensions	.78" x 2.75" x 1.1"

# LIMIT SWITCH ADJUSTMENT

## **⚠ CAUTION**

Please read and understand the following information. Improperly adjusted motor limit switches can result in irreparable damage to the projection screen or motor and will void your warranty.

These instructions refer to screens equipped with the IMC control unit only. For screens with the RTS motor, please refer to the respective RTS motor section (Page 19).

Stewart Filmscreen uses tubular Somfy motors in many of our projection screens. Users may require adjusting the limit switches at some point in time.

Tool required: 4 mm hex key or 5/32" hex driver. You can also use an electrician's 1/8th inch flat blade screwdriver.

**Note: Never use an electric drill or powered screwdriver to adjust Somfy motor limit switches as this will damage the internal timing assembly in the motor. The switches are designed for manual (by hand) incremental adjustment only.**

## **ADJUSTING THE SCREEN'S DEPLOYED (DOWN) STOPPING POSITION**

This is the number one adjustment that users may need to make. A projection screen may require that the deployed stopping position "white" switch be readjusted from the factory setting.

This adjustment will be made using the "white" limit switch (see Figure 30). It is important to remember that you cannot reduce the screen's deployment setting when the screen is currently stopped at its full "down" setting. You must use the control switch to raise the screen up a foot or so before attempting a motor limit switch adjustment. If the screen is operated by a screen trigger, you must reduce this "white" limit switch when the screen is stopped in its fully retracted, "up" position. Turn the "down" motor limit switch clockwise to reduce top masking settings.

Turning the motor limit switch counterclockwise will increase or extend the screen's deployed stopping position. Switches are sensitive. Go slowly and do quarter turns at all times with the 5/32" hex driver to prevent damage to the motor and to the screen. Do not extend the screen so far that the aluminum roller tube becomes exposed. There must be at least one full wrap of the screen left on the roller tube when the screen is resting at its final deployed setting. If you turn this limit switch too much (clockwise) and the screen is now stopping short of where you want it, simply turn it in the opposite direction (counterclockwise) and the screen will automatically drop in increments as you rotate the switch.

## **⚠ NOTE**

The limit switch is a mechanical adjustment. You will not see the new position until the screen motor is cycled. One full turn will make a 1 1/2" - 2" change.

## LIMIT SWITCH ADJUSTMENT (CONTINUED)

### ADJUST THE SCREEN'S RETRACTED (UP) STOPPING POSITION

**CAUTION:** Making adjustments to the yellow switch can inadvertently damage the screen or the motor if the fully retracted stopping position is set too high into the housing. This will cause the screen's batten bar to impact the screen roll and may cause optical damage to the screen. Improper adjustment can also cause the batten to jam into the housing which obstructs it from deploying when the "down" command is sent. Left in this position, the motor will fail due to overrun. Only qualified, experienced technicians should attempt to make adjustments to the "up" yellow limit switch (see Figure 30).

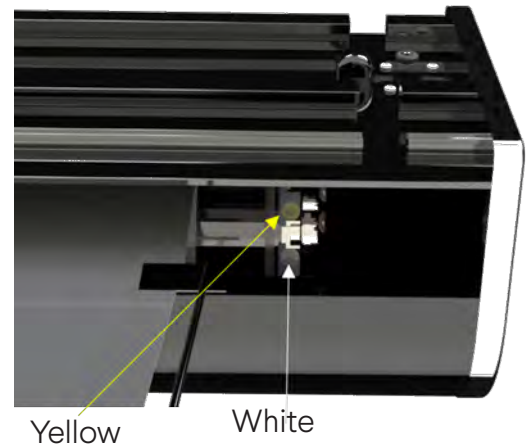

**NOTE: Failure to follow these directions may result in voiding your warranty.**

In the fully "up" retracted stopping position, the screen's batten bar must hang freely underneath the screen roller tube. The batten bar cannot contact or press against the projection screen roll. Make sure to check and correctly adjust the yellow or "up" limit switch to avoid screen damage from a compacted batten bar. Switches are sensitive. Go slowly and do quarter turns at all times with the 5/32" hex driver to prevent damage to the motor and to the screen.

Counterclockwise adjustments of this switch will raise the batten bar and clockwise adjustments will lower the batten's top setting. Lowering the batten's top stopping position is valuable when trying to align the screen's batten with the bottom of the Luxus case.

#### **⚠ CAUTION**

Please remember that improperly adjusted motor limit switches will cause damage to your projection screen or motor. Make sure that both of the motor limit switches have been properly adjusted, allowing the projection screen to stop correctly at both the retracted and deployed positions.

# ADJUSTING THE SCREEN TENSION

To correctly adjust the batten setting position and side line length on your Stewart screen, it may be necessary to loosen the existing side line attachment screws. After the adjustment has been completed, the batten weight will be increased on the screen while decreasing the side line tension.

This procedure can improve the overall flatness of the screen primarily in the lower section of the image area. In many instances, the screen's factory deployment setting has been reduced at the site and therefore this batten adjustment is necessary.

The objective is to thread the screw into the ferrule just enough to get a very low amount of side line tension (approximately 3 to 4 turns). The side lines will now have less tension which is desirable. The result is that more batten weight will be distributed on the screen once this adjustment is completed. You should see a slight improvement when finished; however, it will take some time for this adjustment to fully take effect (stretching screen) thereby eliminating any wrinkles, waves, or puckers.

## SCREEN TENSION ADJUSTMENT PROCEDURE

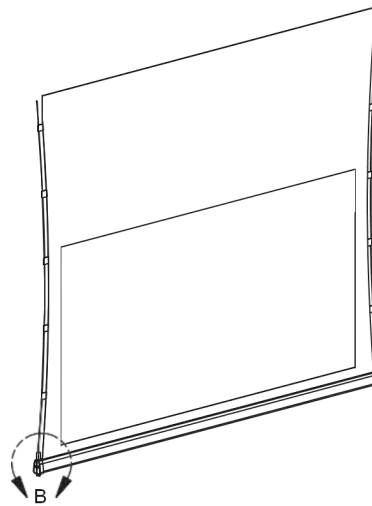

Front of Screen

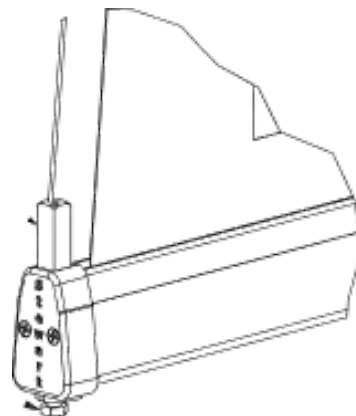

Detail B: Batten Overview

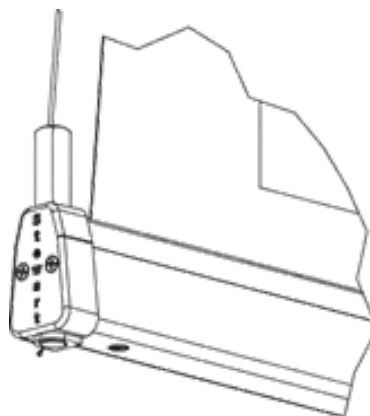

Detail B: Batten Underside

1. Push the ferrule down.

2. Turning the screw counter-clockwise will lengthen the side line, adding batten weight / tension to the screen. Turning it clockwise will shorten the side line and decrease batten weight / tension on the screen.

3. Align the bottom screw to the recessed pocket and release it to move the ferrule back in place and complete adjustment.

## BONNET (FASCIA) REMOVAL

Luxus now offers a two-piece construction that allows the bonnet (front fascia) to come off for servicing. This allows easy access to the control system and roller tube assembly without having to take the entire unit down. To remove the bonnet:

1. Remove the four hex head 10-32 screws from each end cap, left and right (see Figure 31)

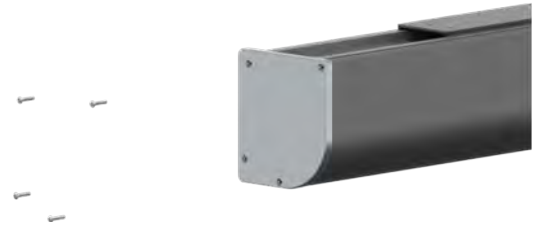

Figure 31. Audience left, front of unit, showing screws removed

2. Remove both end caps as you undo the last screw from each side (see Figure 32).



Figure 32. Audience left, front of unit showing endcap removed

3. Slide the bonnet off. Carefully place in a safe location (see Figure 33).



Figure 33. Audience left, front of unit, showing bonnet removed

Installation is the reverse of the uninstalling instructions.

# CARING FOR AND CLEANING THE SCREEN

---

With reasonable care, you may expect many years of dependable use of your Stewart projection screen.

## GENERAL MAINTENANCE

The surface of your screen is delicate, so we encourage you to keep your screen clean. Special attention to these instructions should be followed when cleaning.

### **⚠ CAUTION**

- ▶ Oils and grease from hands can easily transfer to screen material.
- ▶ Be careful not to touch or scratch the viewing surface.

- ▶ Avoid getting any foreign objects on the screen as cleaning may prove very difficult. It may not be possible to remove scratches, paint, ink, etc.
- ▶ A draftsman-style brush may be used to lightly whisk away any loose dirt or dust particles. This type of brush is usually available at office supply stores.
- ▶ For tougher spots, you can make a cleaning solution using a water-based detergent and warm water. To make the solution, mix one part Simple Green, 409, or other water-based industrial cleaner with three parts warm water. Moisten a clean cotton cloth or cotton swab with this solution, moisten the stained area, and gently lift off the stain. Never use an aggressive scrubbing action as you could damage the screen surface by removing the optical coating. Remoisten the area with clean water and dab dry with a clean sponge or cotton cloth. Any residual watermarks will evaporate on their own within minutes.
- ▶ Contact the factory if you have questions about removing difficult spots.
- ▶ If brushed aluminum endcaps were selected instead of painted endcaps, you may notice slight tarnishing of aluminum surface over time. If this happens, take a high quality microfiber towel and hand buff the tarnish away.

### **⚠ CAUTION**

Do not use cleaners containing alcohol as they can damage the optical surface of the screen fabric.



# TROUBLESHOOTING

Refer to the following guidelines if you encounter any difficulty in the operation of your Stewart screen. Problems related to electrical or motor function may require a qualified service person or electrician. Should you have a problem that is not addressed below, please call Stewart Filmscreen at 1 (310-784-5300) or toll free 1 (800-762-4999) for assistance.

Problem	Cause	Action Steps
The screen won't operate	No AC power available	Check to see if the circuit breaker has switched off. Reset if needed. Check the outboard switching apparatus. Check voltage availability. Contact an electrician
The screen won't roll up or down (even though power is available)	Bad connection at the switch. Polarity of IMC line may be bad	Have an electrician or qualified service person check control board connections
The screen roller chatters when power is activated	Can be caused by voltage drop, bad connections, or a defective switch	Have an electrician or qualified service person check all hook-ups including outboard wiring
The unit hums in "up" mode	The screen batten is retracting too far into the case. Failure to correct can damage the motor and the screen. Do not use the unit until this problem is resolved	Have a qualified service person adjust the yellow UP limit switch
The screen drops when "up" direction is activated	Could be a drop in voltage	Screen motor requires full voltage. Have an electrician or qualified service person check available voltage
The screen continues past bottom stop position	"White" limit switch is out of adjustment	Readjust the "white" down limit switch. See the section on Adjusting Screen Deployment of this manual (Page 24)
The batten retracts too far into case	"Yellow" limit switch is out of adjustment. Failure to correct can damage motor and screen. Do not use the unit until the problem is resolved	Have a qualified service person adjust the "yellow up" limit switch

## TROUBLESHOOTING CONTINUED

---

<p>The motor shuts off. The motor has been in use for more than 2 minutes</p>	<p>The motor is designed for short operations (lowering and retracting), not continuous duty. Longer operation causes the motor to overheat and shut off</p>	<p>Allow the motor to cool down. Complete cooling can take an hour or more. Heat gain is cumulative and takes time to dissipate. If motor use is initiated before it has cooled completely. The motor will shut down again when it reaches maximum temperature</p>
<p>Dirt, fingerprints, marks, etc., on the screen surface</p>	<p>Improper handling of screen</p>	<p>Lightly brush off or use a mild water-based detergent solution with a clean rag or cotton swab</p>
<p>Indentations appear on screen surface</p>	<p>Debris or particles adhering to screen due to static cling</p>	<p>Check back of screen; gently brush debris away with a soft brush</p>
<p>Brushed aluminum end caps on case appear dull in color</p>	<p>Aluminum finish may be tarnishing normally due to age and exposure</p>	<p>Take a clean high quality microfiber towel and hand buff aluminum endcaps to remove any tarnishing</p>

## ONE (1) YEAR LIMITED WARRANTY

---

STEWART FILMSCREEN CORPORATION (Stewart) warrants all products to the original purchaser only. Stewart products are guaranteed to be free from defects in materials and workmanship for a period of one (1) year from the date of purchase by the original purchaser or eighteen (18) months from date of manufacture, as defined in the serial number. Additionally, all products must be properly operated and maintained according to Stewart instructions and cannot be damaged due to improper handling or treatment after shipment from the factory. This warranty does not apply to equipment showing evidence of misuse, abuse, or accidental damage, including neglect caused by improper installation (i.e. proximity to hot lights, exposure to extreme heat or cold, exposure to excessive humidity, etc.).

Stewart on-site warranty repair services are not available for this product. Stewart's sole obligation under this warranty shall be to repair or to replace (at Stewart's sole discretion) the defective part of the merchandise. This warranty expressly does not cover any costs of removal, installation, framing, or other costs incidental to replacing the screen or returning it to Stewart. Returns for service should be made to your Stewart dealer. If it is necessary for the dealer to return the screen or part to Stewart, transportation (freight) expenses to and from Stewart are payable by the purchaser. Stewart is not responsible for damage in shipment. To protect against damage or loss in transit, insure the product and prepay all transportation expenses.

This warranty is in lieu of all other warranties, expressed or implied, including warranties as to fitness for use or merchantability. Any implied warranties of fitness for use or merchantability, which may be mandated by statute or rule of law, are limited to the one (1) year warranty period. This warranty gives you specific legal rights, and you may also have other rights which vary from state to state. In no event will Stewart be liable for sums in excess of the purchase price of the product. No liability is assumed by Stewart for expenses or damages resulting from interruption in operation of equipment, or for incidental, direct, or consequential damages of any nature. In the event that there is a defect in materials or workmanship of a Stewart Filmscreen product, you may contact our customer service department at 1161 W Sepulveda Blvd, Torrance, CA 90502- 2797, or call us at 1 (310) 784-5300, or toll free at 1 (800) 762-4999.

**IMPORTANT: This warranty shall not be valid and Stewart shall not be bound by this warranty if the product is not operated and maintained in accordance with Stewart's written instructions. Stewart Filmscreen Corporation shall not be liable for any and all consequential damage(s) occasioned by the breach of any written or implied warranty pertaining to the sale of a Stewart Filmscreen product in excess of the purchase price of the product sold.**

XXX



The Reference for Stunning™

[www.stewartfilmscreen.com](http://www.stewartfilmscreen.com)

1161 W. Sepulveda Blvd., Torrance CA 90502 USA | 800.762.4999 | Tel: 310.784.5300 | Fax: 310.539.7440 | Email: [request@stewartfilmscreen.com](mailto:request@stewartfilmscreen.com)

©2025 Stewart Filmscreen. Specifications are subject to change without notice.