

# Stealth Grande

Retractable, Above Ceiling Screen System with Trapdoor

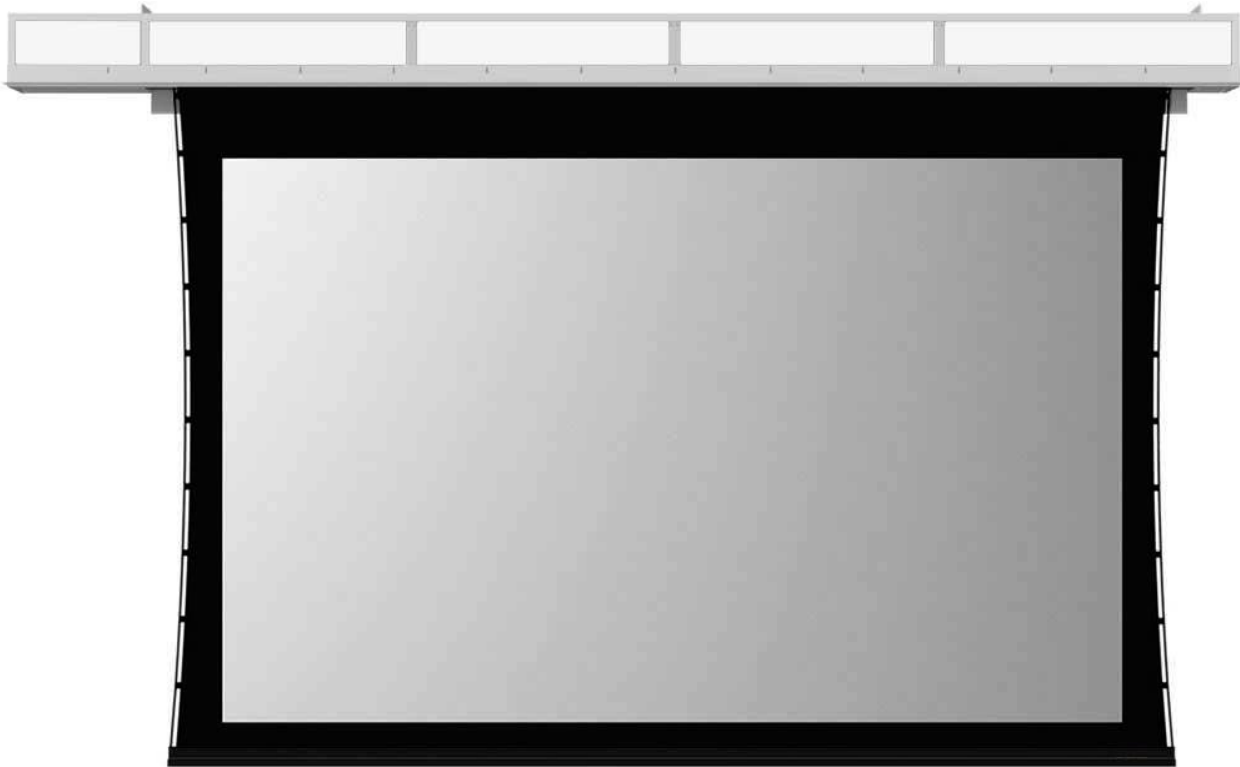

**Stewart**  
F I L M S C R E E N

The Reference for Stunning™

Printed in U.S.A.

©2020 Stewart Filmscreen Corporation

Stewart Filmscreen reserves the right to make changes to the product specified in this document.

From time to time, this document is updated. Current versions of documentation are posted on the Stewart Filmscreen website at:

[www.stewartfilmscreen.com](http://www.stewartfilmscreen.com)

# Stealth Grande

## OWNERS MANUAL

---

### Contents

To the Owner .....	2
Preparing the Installation .....	2
Step 1. Hanging the Case .....	4
Step 2. Electrical Hook-up .....	5
Operating the Screen .....	7
Adjusting the Screen Extension .....	8
Screen Care and Cleaning .....	9
Troubleshooting .....	10
Product Warranty .....	12

---

## **TO THE OWNER**

---

Congratulations on your purchase of the finest optical viewing screen available anywhere in the world!

Please take a moment to review this manual, it will help ensure you many years of trouble-free service from your new Stewart Filmscreen product.

### **About your Stealth Grande ElectriScreen**

---

Your Stealth Grande ElectriScreen offers the most technologically advanced trapdoor roller screen in the world. The hingeless door is powered by its own motor.

---

## **PREPARING THE INSTALLATION**

---

- ◆ **Before proceeding with the installation of this screen, take time to thoroughly read and understand these installation and operation instructions.**
- ◆ **All electrical wiring installations must conform to local and national codes and should be performed by qualified service personnel.**
- ◆ **There are no user-serviceable parts contained within the unit.**

### **Preparation**

---

Specifications regarding the individual screen dimensions, weight, mounting type, and controls are provided by the factory when the unit is ordered. Before beginning the installation:

- ◆ Check the specifications for the type of mounting and switch control to be used.
- ◆ Ensure that the mounting area and electrical connection are prepared.
- ◆ Check the size and weight of the screen to be installed so that you can plan for the number of people required for the mounting procedure.

You will need:

- ◆ Enough ladders and/or hydraulic lift for the personnel supporting the screen during the mounting process
- ◆ A level
- ◆ Fasteners appropriate for the surface on which the screen is being mounted

---

**Note:** This manual refers to “AC” to represent electrical power. Your location may use 120 V, 220 V, or other electrical power. Screen systems are manufactured using the electrical power type specified for the location. Use appropriate power sources for your location.

## **Unpacking**

---

1. DO NOT remove the paper hanging from the trapdoor at this time. You should remove it only after the unit is hung, all electrical connections have been made, and the screen is in operation.
2. When moving the unit, make sure not to torque or twist the case. This can cause door alignment problems. To check the case, use a level on the case ends.

### **Caution**

**During installation, do not place the unit on an unstable cart, stand, table, or ladder. The unit may fall, causing injury to a child or adult and damage to the unit.**

---

## **STEP 1. HANGING THE CASE**

---

**Professional mounting techniques should be used. Stewart Filmscreen Corporation cannot be liable for substandard or faulty installations.**

Make sure that you mount the screen so that the electrical box is on the left side (audience left).

### **Installing the unit**

---

The Model BB Trapdoor ElectriScreen is ready to install into the ceiling or soffit. A false ceiling is not intended to support the weight of the Model BB Trapdoor ElectriScreen.

The screen can be bolted directly to the support structure or suspended. If the unit is to be mounted to plaster, drywall, masonry, or other type of surface, use an appropriate fastener.

1. Install the unit onto the support structure making sure that the bottom of the case is flush with the finished ceiling plane.
2. Make sure the unit is level.

## STEP 2. ELECTRICAL HOOK-UP

### Caution

Professional techniques should be used when making any electrical connection. A qualified electrician should perform these procedures.

Be sure to follow all standard safety procedures for installing electrical devices.

Do not disassemble or alter the configuration of the motor or the unit's electrical connections. This may cause injury to you or damage to the product.

The electrical connection should be made only to the type of power source indicated on the marking label.

The motor requires standard AC input (unless an alternate voltage has been specified).

There are several kinds of switch controls available. Follow the installation procedure for the type of switch control you will install.

General suggestions for wiring:

- ◆ Soldering is recommended.
- ◆ The use of wire nuts is acceptable.

### Preparation—Removing access panel

All connections are made to the electrical box on the side of the unit (audience left). An access panel covers the electrical connections. To remove the access panel on the underside of the unit, remove the two hex screws. Refer to Figure 1. Replace the access panel after the electrical connections have been made.

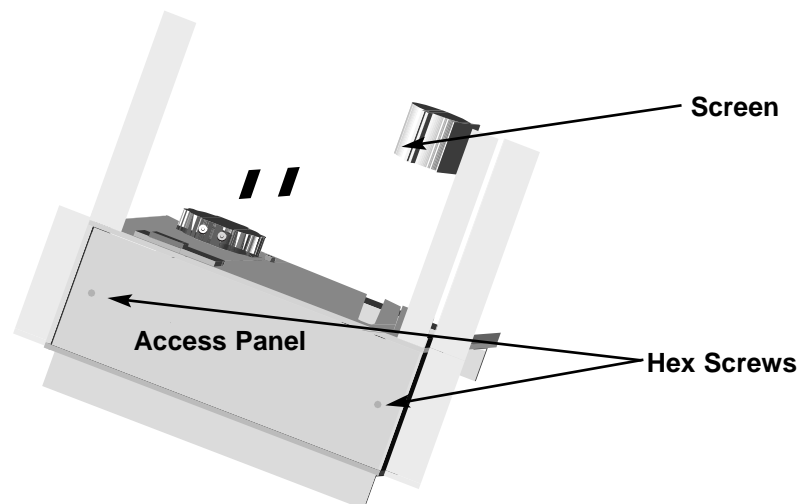

Figure 1: Stealth Grande underside view

---

## Installing the low-voltage 3-button switch (standard)

---

The Stewart Filmscreen low-voltage control allows the use of low-voltage wire to connect to the supplied 3-position 24V momentary wall switch.

**Note:** When the low-voltage 3-button switch is ordered, the control box is pre-mounted at the factory.

### Preparing the connection

Before making the electrical connections, you need:

- ◆ An available AC constant power source
- ◆ A 4-conductor switch hook-up cable (4-conductor bell wire or category 5 cable is typically used for long runs)
- ◆ Cat 5, multi-conductor unshielded, or similar type electronic cable can be used to connect the 3-button switch to the L VC. The recommended wire gauge is 20 to 24 AWG. Use plenum-rated cable when required.

### Making the connection

Figure 2 illustrates the connections.

1. Connect the 4-conductor cable to the connection harness coming from the J-box labeled “switch input.”
2. Connect the hookup cable to the 3-button switch.
3. Connect the main AC power source to the J-box labeled “main AC power connection.”
4. A parallel connection to an outboard audio-visual switching network can be made at this time. (optional)

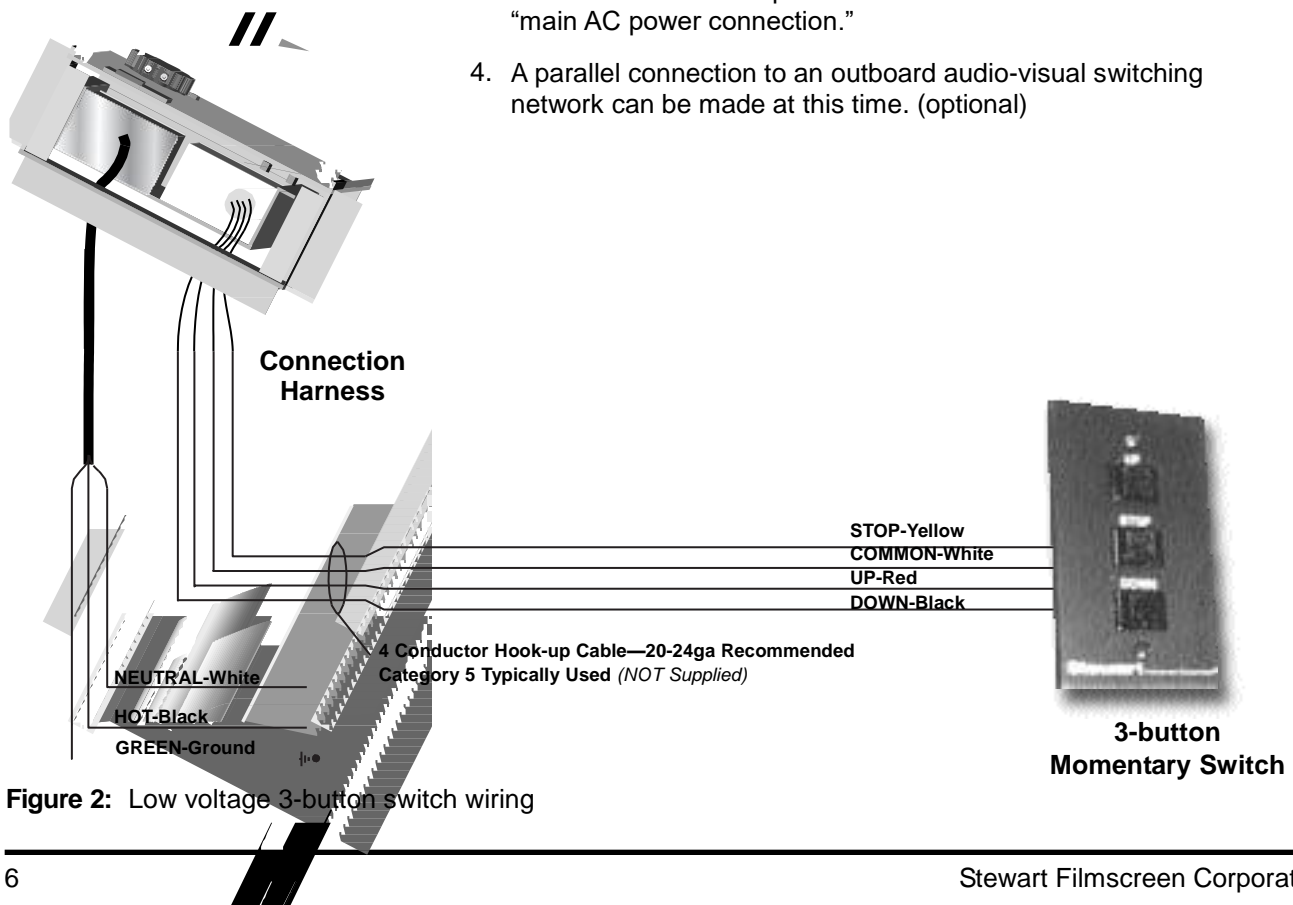

Figure 2: Low voltage 3-button switch wiring



---

## **OPERATING THE SCREEN**

---

### **First time operation**

**The first time you operate the screen, the protective paper will fall out as the screen unrolls. Once the screen is fully displayed, make sure that no packing paper remains on the screen roll. The screen can be damaged if loose paper remains.**

The method you use to raise and lower the screen depends on the type of switch control device you have selected.

When you lower or retract the screen, it will stop at its preset limit. If an obstacle (such as a person or furniture) gets in the path of the screen as it is lowered, you should use the switch control to stop the screen's motion; it will not automatically stop if it hits an obstacle.

The motor is designed to be used for short operations such as lowering the screen in preparation for viewing. The motor is not designed for continuous duty. If the motor operates continually for more than a few minutes, it may automatically shut off to prevent damage from overheating. If the motor occasionally needs to be run more than normal, for example during initial setup and positioning, allow time for the motor to cool down.

In general, when the screen is not in use, you should store it in the fully retracted position.

### **Caution**

**Do not operate the motor when any of the following occurs:**

- ◆ **The unit emits any smoke, heat, abnormal noise or unusual odor.**
- ◆ **The unit is damaged in some way, such as damage from a water leak.**

**If any of these situations occur, call a qualified service person.**

## ADJUSTING THE SCREEN EXTENSION

### Caution

Improper adjustment of the limits can cause irreparable damage to the screen itself, resulting in voiding the factory warranty.

The extension and retraction limits have been preset at the factory. In general, we advise you to avoid readjusting these limits.

In some cases, to enable proper alignment of the displayed image on the screen, you may need to adjust the extension of the screen. If adjustment to the extension is necessary, carefully follow these instructions.

### Warning!

The screen is fully retracted when the batten is flush with the bottom of the case. Do not attempt adjustments with the blue retraction (UP) thumbwheel that will further retract the screen. Incorrect adjustment of the thumbwheel will cause severe screen damage. Please consult the factory if you have any questions.

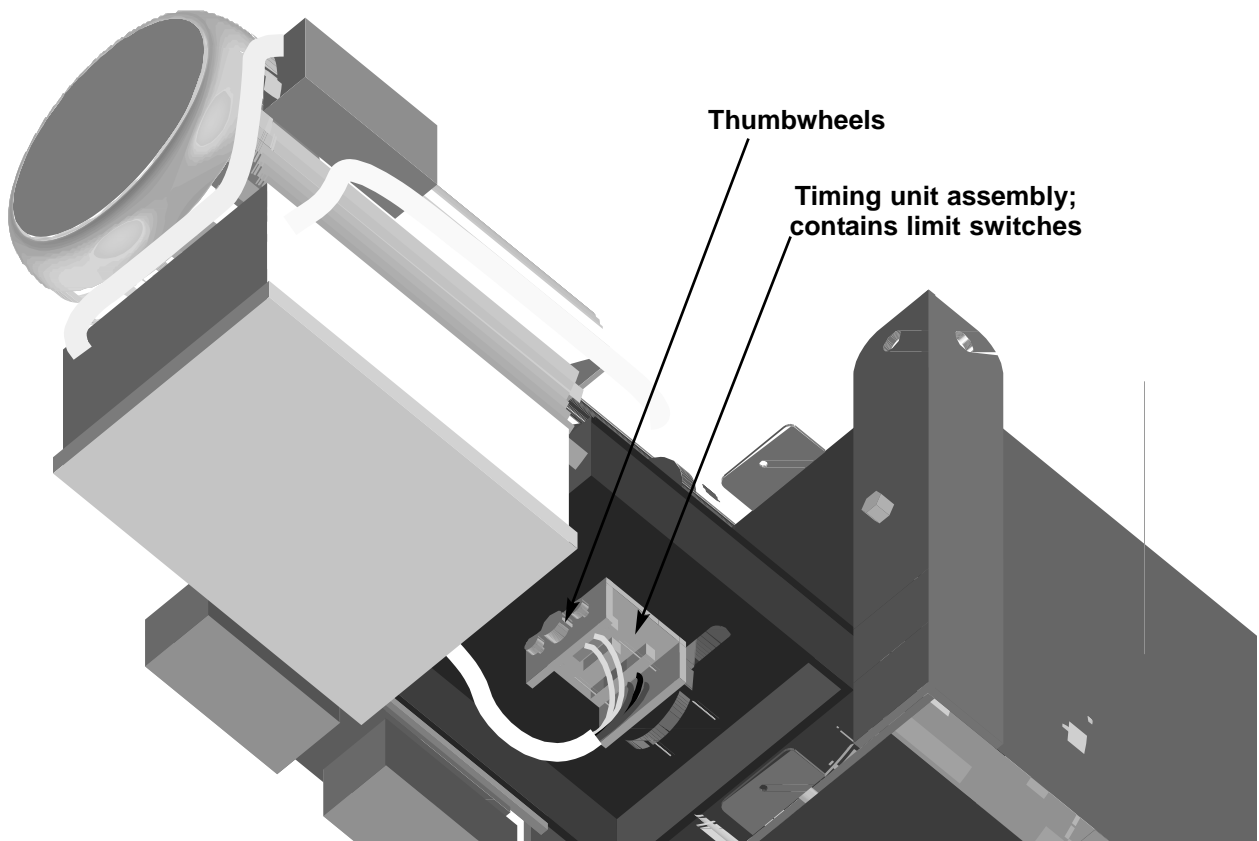

Figure 3: Underside view

---

## **SCREEN CARE AND CLEANING**

---

With reasonable care, you may expect many years of trouble-free use of your Stewart projection screen.

We encourage you to keep your screen clean. To protect your screen when it is not in use, store it in the fully retracted position.

Avoid getting any foreign material on the screen, as cleaning may prove very difficult. It may not be possible to remove scratches, paint, ink, etc.

### **General maintenance**

---

The screen surface on your screen is delicate. Special attention to these instructions should be followed when cleaning.

- ◆ A draftsman-style brush may be used to lightly whisk away any loose dirt or dust particles. (This type of brush is usually available at office supply stores.) Stewart Filmscreen has an optional screen cleaning kit that contains the proper type of brush. Contact your dealer if you would like to obtain this cleaning kit.
- ◆ Particles left on the screen when it is retracted into the case may form an impression on the screen surface. Periodically wipe the back of the screen with a clean damp cloth.
- ◆ For tougher spots, use a solution of mild detergent and water. Rub lightly using a sponge. Blot with a damp sponge to absorb excess water. Residual water marks will evaporate within a few minutes. Let the screen air dry completely before retracting.

Do not use any other cleaning materials on the screen. Contact the factory if you have questions about removing difficult spots.

### **Replacement parts and service**

---

No user-serviceable parts are contained within the unit. Contact your dealer or the factory if you require part replacement or service.

# TROUBLESHOOTING

Refer to the following guidelines if you encounter a difficulty in the operation of your Stewart Filmscreen. Problems related to electrical or motor function may require a qualified service person or electrician.

Should you have a problem that is not addressed here, call the Stewart Filmscreen Corporation.

Problem description	Probable cause	Action to take
Screen won't operate. Door won't open.	No AC power available. Outboard switching problem.	Check to see if the circuit breaker has switched off. Reset if needed. Check outboard switching apparatus. Check voltage availability. Contact an electrician. Check that the toggle switches are in the correct position.
Screen won't roll up or down (even though power is available).	Bad connection at switch. Polarity of STI line may be bad.	Have an electrician or qualified service person check the connection as follows: <ul style="list-style-type: none"> <li>• If you have a <i>low voltage control</i> unit, check switch-line connections.</li> <li>• If you have a <i>screen trigger interface</i>, check line connections, or the mini-plugs at the screen input or projector output. Check 12V DC line for correct polarity. Contacts may be sticking —tap relay to free contacts.</li> </ul>
Screen roller chatters when power is activated.	Can be caused by voltage drop, bad connections, or a defective switch.	Have an electrician or qualified service person check all hook-ups including all outboard wiring.
Unit hums in up mode. (Screen has already retracted.)	The screen batten is retracting too far into the case. <b>Failure to correct can damage motor and screen. Do not use the unit until this problem is resolved.</b>	Have a qualified service person adjust the yellow UP limit switch. Turn the adjusting screw clockwise. See pp. 8 of this manual.
Screen drops when up direction is activated (grinding noise occurs).	Drop in voltage.	Screen motor requires full voltage. Have an electrician or qualified service person check available voltage.
Screen continues past bottom stop position.	White limit switch is out of adjustment.	Readjust the white DOWN limit switch. See pp. 8 of this manual.
Batten retracts too far into case.	Yellow limit switch out of adjustment. <b>Failure to correct can damage motor and screen. Do not use the unit until this problem is resolved.</b>	Have a qualified service person readjust the yellow UP limit switch. See pp. 8 of this manual.

<b>Problem description</b>	<b>Probable cause</b>	<b>Action to take</b>
Motor shuts off. Motor has been in use for more than 2 minutes.	Motor is designed for short operations (lowering and retracting), not continuous duty. Longer operation, such as during setup and positioning, causes the motor to overheat and shut off.	Allow the motor to cool down. Complete cooling can take an hour or more. Heat gain is cumulative and takes time to dissipate. If motor use is initiated before it has cooled completely, the motor will shut down again when it reaches maximum temperature.
Any controller (e.g., STI, LVC, etc.) fails to operate motor.		
Dirt, finger prints, marks, etc. on screen surface.	Improper handling of screen.	Brush off or use a mild detergent solution with clean rag or cotton swab.
Indentations appear on screen surface.	Debris or particles adhering to screen due to static cling.	Check back of screen; gently brush debris away by hand.

## LIMITED ONE YEAR WARRANTY

---

STEWART FILMSCREEN CORPORATION (Stewart) warrants all products to the original purchaser only. Stewart products are guaranteed to be free from defects in materials and workmanship for a period of one (1) year from the date of purchase by the original purchaser or eighteen (18) months from date of manufacture, as defined in the serial number. Additionally, all products must be properly operated and maintained according to Stewart instructions and cannot be damaged due to improper handling or treatment after shipment from the factory. This warranty does not apply to equipment showing evidence of misuse, abuse, or accidental damage, including neglect caused by improper installation (i.e. proximity to hot lights, exposure to extreme heat or cold, exposure to excessive humidity, etc.)

Stewart on-site warranty repair services are not available for this product. Stewart's sole obligation under this warranty shall be to repair or to replace (at Stewart's sole discretion) the defective part of the merchandise. This warranty expressly does not cover any costs of removal, installation, framing, or other costs incidental to replacing the screen or returning it to Stewart. Returns for service should be made to your Stewart dealer. If it is necessary for the dealer to return the screen or part to Stewart, transportation (freight) expenses to and from Stewart are payable by the purchaser. Stewart is not responsible for damage in shipment. To protect against damage or loss in transit, insure the product and prepay all transportation expenses.

This warranty is in lieu of all other warranties, expressed or implied, including warranties as to fitness for use or merchantability. Any implied warranties of fitness for use, or merchantability, that may be mandated by statute or rule of law are limited to the one (1) year warranty period. This warranty gives you specific legal rights, and you may also have other rights which vary from state to state. In no event will Stewart be liable for sums in excess of the purchase price of the product. No liability is assumed by Stewart for expenses or damages resulting from interruption in operation of equipment, or for incidental, direct, or consequential damages of any nature. In the event that there is a defect in materials or workmanship of a Stewart Filmscreen product, you may contact our Customer Service Department at 1161 W Sepulveda Blvd, Torrance, California 90502- 2797 (310-784-5300) Toll free (800-762-4999).

**IMPORTANT:** This warranty shall not be valid and Stewart shall not be bound by this warranty if the product is not operated and maintained in accordance with Stewart's written instructions. Stewart Filmscreen Corporation shall not be liable for any and all consequential damage(s) occasioned by the breach of any written or implied warranty pertaining to the sale of a Stewart Filmscreen product in excess of the purchase price of the product sold.

xxx



The Reference for Stunning™

[www.stewartfilmscreen.com](http://www.stewartfilmscreen.com)

1161 W. Sepulveda Blvd., Torrance CA 90502 USA | 800.762.4999 | Tel: 310.784.5300 | Fax: 310.326.6870 | Email: [request@stewartfilmscreen.com](mailto:request@stewartfilmscreen.com)

©2020 Stewart Filmscreen. Specifications are subject to change without notice.