

WallScreen 1.5

Fixed Frame, Snap Screen



Stewart
F I L M S C R E E N

The Reference for Stunning™

Printed in the USA. ©2022 Stewart Filmscreen Corporation

Stewart Filmscreen reserves the right to make changes to the product specified in this document.

Sizes and specifications are subject to change without notice at Stewart's discretion. From time to time, this document is updated. Current versions of this documentation are posted on the Stewart Filmscreen website at: www.StewartFilmscreen.com

Revision 2.01.03
Date: 08/16/2022

WallScreen 1.5

OWNER'S MANUAL

Contents

To the Owner	4
About WallScreen 1.5	5
Preparing the Installation	6
Frame Assembly Instructions	8
Wall Board Mount	9
Eye Bolt Mount (Hanging)	11
T-Stand (Self-Supporting)	12
Aperture Mount	13
Attaching the Screen to the Frame	14
Attaching the Back Brace to the Frame	16
Caring for and Cleaning the Screen	17
One (1) Year Limited Warranty	18

TO THE OWNER

Congratulations on purchasing one of the finest optical viewing screens in the world.

Your handcrafted, WallScreen 1.5 projection screen has been carefully inspected to ensure you will have an optimal viewing experience that will last many years. Please take a moment to review this manual. It will guide you through the installation and the operation of your screen and will also provide you with detailed instructions on how to care for your screen's viewing surface.

From all of us at Stewart Filmscreen, we would like to thank you for choosing WallScreen 1.5. Should you have any questions, please don't hesitate to contact our customer service department at 1 (310) 784-5300, or toll free at 1 (800) 762-4999. We're here to help.

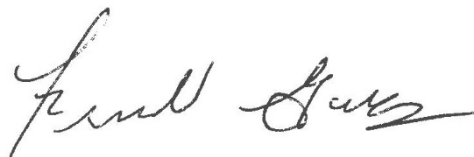

Frank Gomez
Fixed Frame Masking Specialist

ABOUT WALLSCREEN 1.5

Your WallScreen 1.5 fixed frame supports virtually all projection applications. The Velux finish is designed to absorb any projector overscan. The WallScreen 1.5 features angled corners and a beveled edge that brings the image area closer to the front of the frame.

The WallScreen 1.5 features snaps and brackets that move on the frame to allow for adjustments. The standard mount is a Wall Board Mount. Other options include, Eye Bolt Mount (Hanging), T-Stand (Self-Supporting), and Aperture Mount.

USING THIS MANUAL FOR INSTALLATION

If you are using this manual to install the WallScreen 1.5, you should be aware that it describes procedures for several types of mounts. You must refer to the section for the type of mounting system you are utilizing. In addition, there are general instructions for attaching the screen to the frame that are provided in a separate section. This procedure is to be performed at a specific step in the overall sequence.

VOIDING YOUR WARRANTY

Note: Failure to comply with the instructions and guidance contained in this manual may result in voiding your warranty.

For the instructions related to your specific mount type, refer to the appropriate page:

- ▶ Wall Board Mount (page 9)
- ▶ Eye Bolt Mount (Hanging) (page 11)
- ▶ T-Stand (Self-Supporting) (page 12)
- ▶ Aperture Mount (page 13)
- ▶ Back Braces (page 16)

At the designated point in the installation, you will need to refer to the general instructions for: **Attaching the Screen to the Frame (page 14).**

PREPARING THE INSTALLATION

Before proceeding with the installation, take the time to thoroughly read and understand these installation instructions. Failure to comply with the instructions and guidance contained in this manual may result in voiding your warranty.

SPECIFICATIONS

Specifications regarding the individual screen dimensions, weight, etc., are provided by the factory when the unit is ordered.

Before beginning the installation

- ▶ Make sure there is a clean surface on which to unroll the screen and assemble the frame.
- ▶ Check the size and weight of the screen to be installed so that you can plan for the number of people required for installation. You need at least two people to mount the smaller screens. More people are needed for larger, heavier screens.

What's inside the box?

Inside your WallScreen 1.5 box, you will find everything you need to get started on enjoying your Stewart screen:

- ▶ Screen image rolled up in a tube
- ▶ Disassembled frame with all the hardware needed to reassemble
- ▶ Packing material
- ▶ Your specifically optioned mounting hardware
- ▶ Quick Start Guide

You will need:

- ▶ A drill
- ▶ A level
- ▶ A drop cloth
- ▶ Tools for tightening fasteners
- ▶ Lint-free, clean cloth gloves for handling the screen
- ▶ Fasteners appropriate for the surface on which the screen is being mounted
- ▶ Ladder(s) for the personnel supporting the screen during the mounting process

PREPARING THE INSTALLATION (CONTINUED)

Note: Bolts and other fasteners for the screen are standard gauge and standard sizes used in the U.S., regardless of the installation country. For this reason, sizes are in inches rather than metric measurements.

UNPACKING

Be sure to unpack carefully in a clean area. Use special care when handling the screen so that it does not become soiled or damaged. If you plan to repack your screen and hardware for transportation to another location, you may wish to photograph or make a note of how it was packed. Retain the packing material for future use, if desired.

CAUTION

Do not stand on the screen tube or store it on its end. This will cause screen damage. If you are not planning to install the screen immediately, make sure it remains horizontal during storage.

FRAME ASSEMBLY INSTRUCTIONS

1. Connect the frame members by matching the numbered dots on the ends of the members.
2. Secure the frame members with the supplied 1/4-20 x 1/2" hex bolts and 1/4-20 washer (see Figure 1).

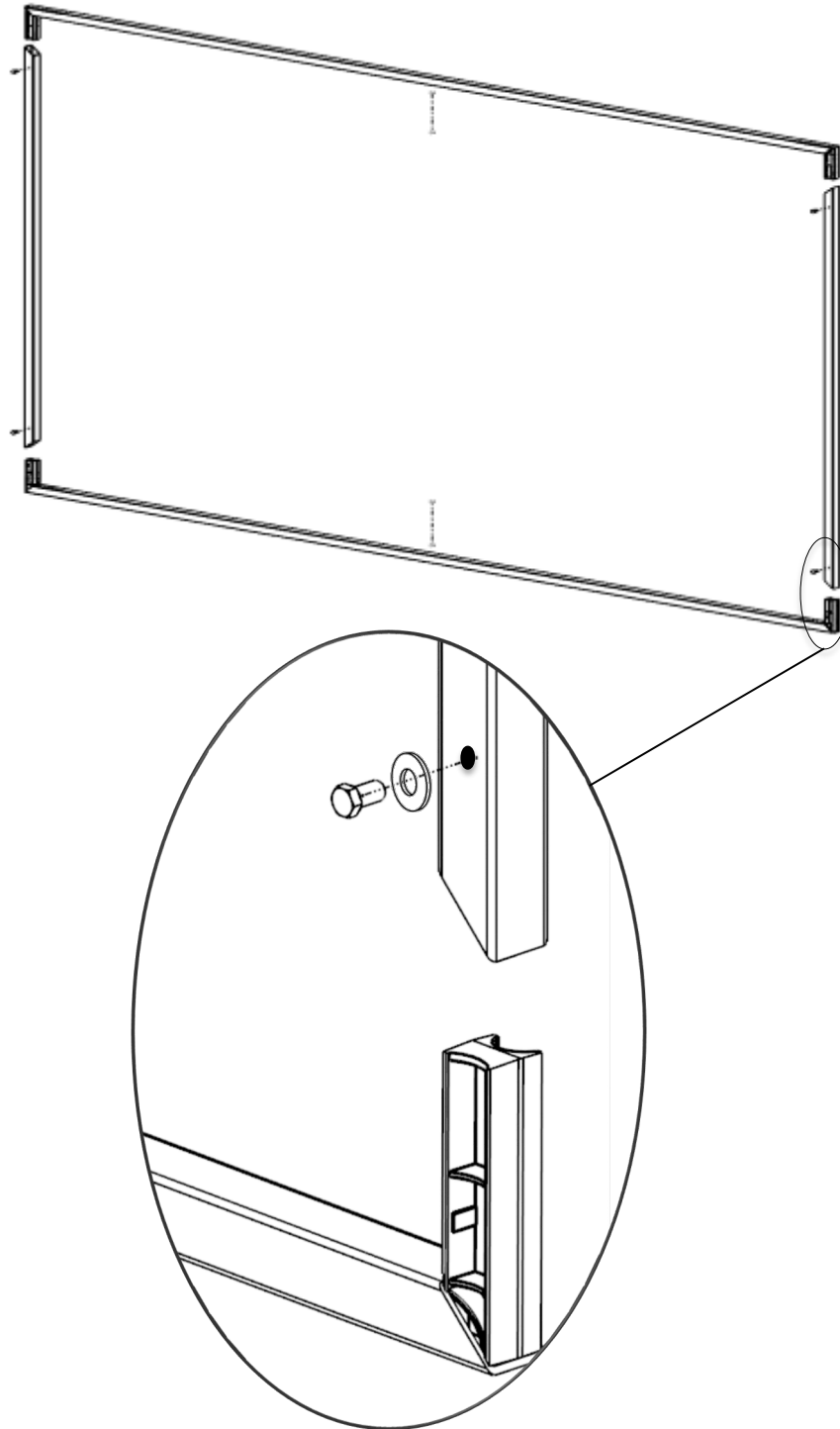

Figure 1: Frame Assembly

WALL BOARD MOUNT

Note: Professional mounting techniques should be used. Stewart Filmscreen cannot be liable for substandard or faulty installations. Failure to comply with the instructions and guidance contained in this manual may result in voiding your warranty.

1. Lay assembled frame face down on a clean surface.
2. Fit wall boards to the outside of the brackets already attached to the frame.
3. Bolt wall boards to brackets using the supplied 3/4" hex head bolts (see Figure 6).

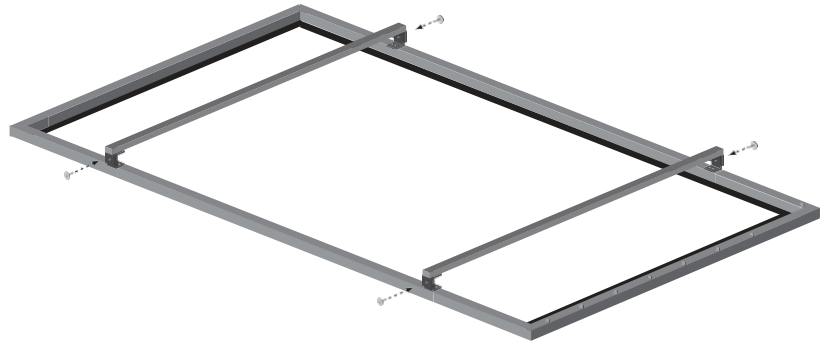

Figure 6: Temporarily Attaching Wall boards to the Frame

Note: Depending on the size of the screen, the number of wall boards may vary. Temporarily attach the wall boards to the frame for the purpose of positioning the frame and brackets on the wall.

4. Without the screen material attached, position the frame and boards on the wall (see Figure 7).
5. Make sure the unit is level and plumb. You may need to use shims between the boards and the wall to achieve vertical plumb.
6. Align the board holes with wall studs. Mark and drill holes in the wall that align with the board holes.

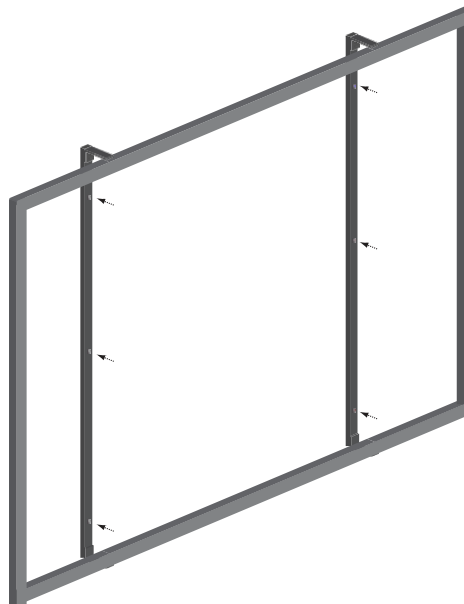

Figure 7: Positioning the Frame and Wall Boards to the Wall

WALL BOARD MOUNT (CONTINUED)

7. Remove the boards from the frame and attach them to the wall using the provided hardware or other such appropriate fasteners such as lag bolts, wall anchors, molly bolts, wood carriage screws, etc. (see Figure 8).
8. Attach the screen to the frame (see pages 17-18).
9. Attach the frame/screen assembly to the previously mounted wall boards on the wall using the 3/4" hex head bolts (see Figure 9).

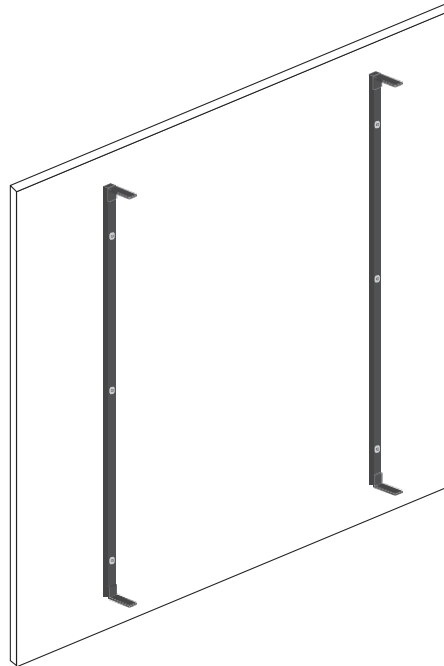

Figure 8: Attaching the Wall Boards to the Wall

Note: On some custom sized frames, the use of additional “back support braces” is required. These vertical support braces assure parallel top and bottom frame member alignment once the screen has been attached to the frame. Do not install the screen/frame without required back braces.

⚠ CAUTION

Be careful not to touch or scratch the viewing surface.

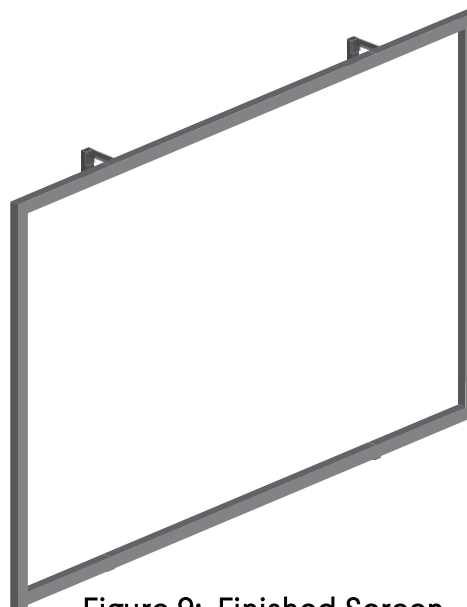

Figure 9: Finished Screen Attached to Wall Boards

EYE BOLT MOUNT (HANGING)

Note: Professional mounting techniques should be used. Stewart Filmscreen cannot be liable for substandard or faulty installations. Failure to comply with the instructions and guidance contained in this manual may result in voiding your warranty.

1. Attach the screen to the frame (see pages 17-18).
2. Use the Eye Bolt Mount to suspend the screen. Eye bolts are already secured to the frame, making your WallScreen ready for installation to an appropriate surface (see Figure 10).

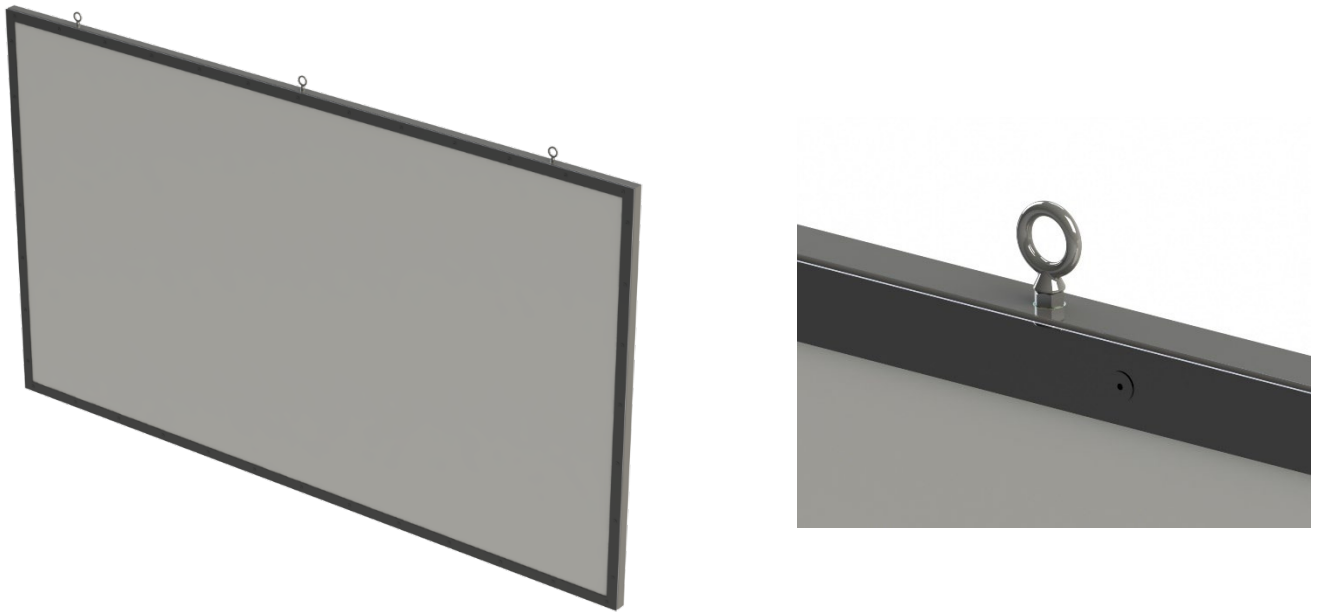

Figure 10: Eye Bolts Mounted Securely to the Frame

Note: On some custom sized frames, the use of additional “back support braces” is required. These vertical support braces assure parallel top and bottom frame member alignment once the screen has been attached to the frame. If back braces are included, do not install the screen/frame without required back braces.

⚠ CAUTION

- ▶ Be careful not to touch or scratch the viewing surface.
- ▶ A false ceiling is **not** intended to support the weight of a WallScreen. Contact a Stewart representative for more information.

T-STAND (SELF-SUPPORTING)

Note: Professional mounting techniques should be used. Stewart Filmscreen cannot be liable for substandard or faulty installations. Failure to comply with the instructions and guidance contained in this manual may result in voiding your warranty.

1. Attach the screen to the frame (see pages 17-18).
2. Use the T-Stand knobs provided to first attach the vertical members to each base, then to attach the finished screen (frame/screen assembly) to the T-Stands. The through-holes on each vertical member should run parallel to the base (see Figure 11).
3. Hand-tighten the knobs.

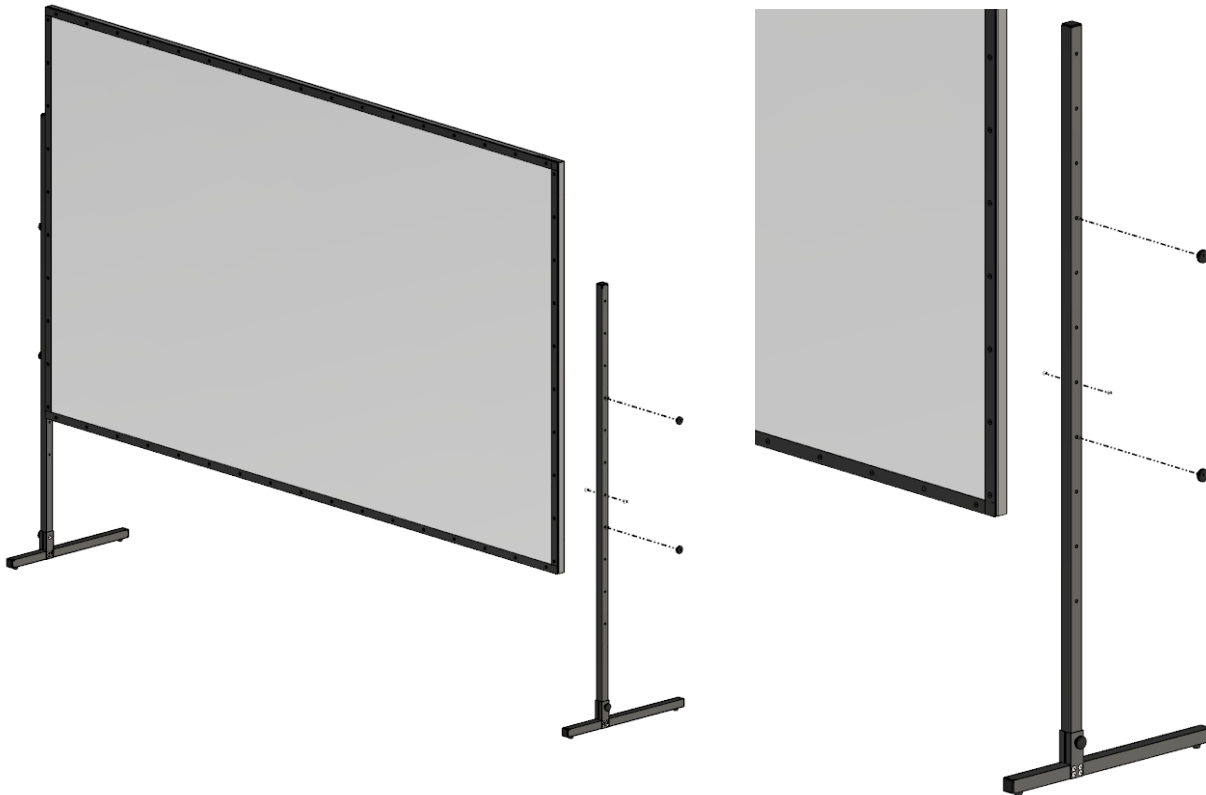

Figure 11: Attaching T-Stand Knobs

Note: On some custom sized frames, the use of additional “back support braces” is required and will be included, if necessary. These vertical support braces assure parallel top and bottom frame member alignment once the screen has been attached to the frame. Do not install the screen/frame without required back braces.

CAUTION

- Be careful not to touch or scratch the viewing surface.

APERTURE MOUNT

Note: Professional mounting techniques should be used. Stewart Filmscreen cannot be liable for substandard or faulty installations. Failure to comply with the instructions and guidance contained in this manual may result in voiding your warranty.

The aperture mount allows you to install the screen into an opening in a wall or wall unit. Access to the back of the screen is required to install the attachment hardware.

1. Prepare the aperture.
2. Attach the screen to the frame (see pages 17-18).
3. Carefully insert the frame (with the screen already attached) into the aperture. Take care so that you do not damage the screen.
4. Install the frame/screen assembly into the aperture using the attached mounting brackets and appropriate fasteners (see Figure 12).



Figure 12: Installing Frame/Screen Assembly – Rear View, Close-up

⚠ CAUTION

Be careful not to touch or scratch the viewing surface.

ATTACHING THE SCREEN TO THE FRAME

DO NOT perform this step UNTIL instructed to do so in the mounting section.

CAUTION

- ▶ Be careful not to touch or scratch the viewing surface.
- ▶ Do not use any tools to fasten the screen to the frame.
- ▶ Do not fold or crease the screen.

UNPACKING AND UNROLLING THE SCREEN

The viewing side of the projection screen is rolled to the inside to protect optical quality. The screen is rolled lengthwise.

1. Remove the screen from the cardboard shipping tube.
2. On a clean surface, unroll the screen **viewing side up** (see Figure 13).
3. Remove the protective packing material from the screen material.

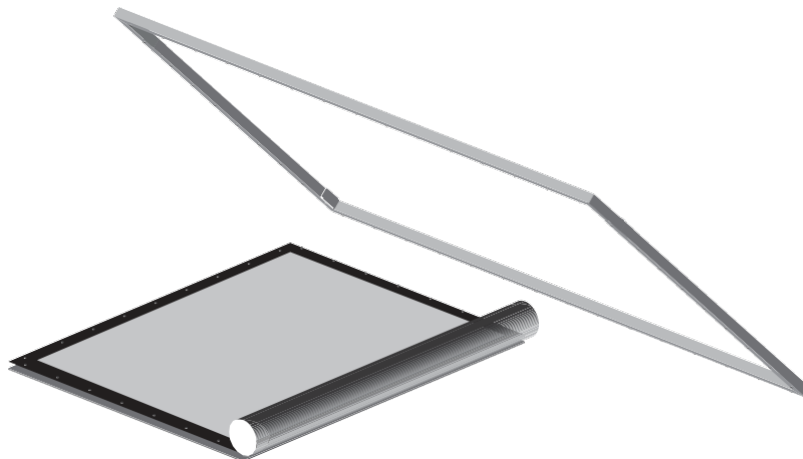

Figure 13: Unrolling the Screen

ATTACHING THE SCREEN TO THE FRAME (CONTINUED)

4. Place the frame over the screen, snap side down (see Figure 13).
5. Starting with the snaps on the top corners and then horizontally along the top while lifting the frame with one hand, snap the screen into the frame. Gently allow the screen to stretch onto the snaps. Do not jerk, wrinkle, or crease the screen material, as the material can be damaged (see Figure 14).
6. Lift the frame to a vertical position to finish attaching the sides and bottom row of the snaps (see Figure 15).

Note: If there are any wrinkles or puckers on the screen, the snaps on the frame can be adjusted side to side. Lay the frame viewing side down on a clean surface. A movement of 1/16" to 1/8" (1.6mm to 3.2mm) is usually sufficient to eliminate puckers.

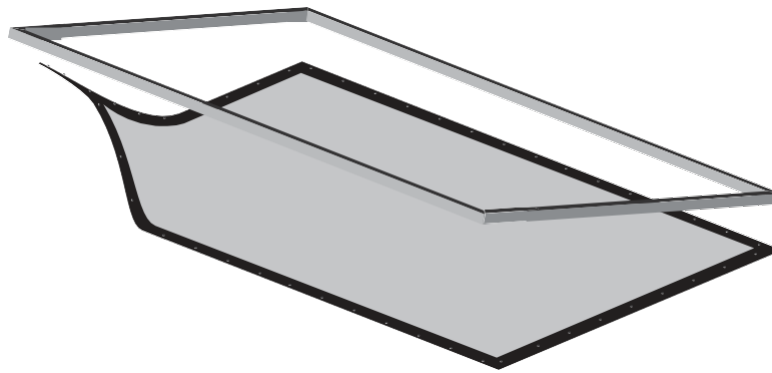

Figure 14: Attaching Top Corner Snaps

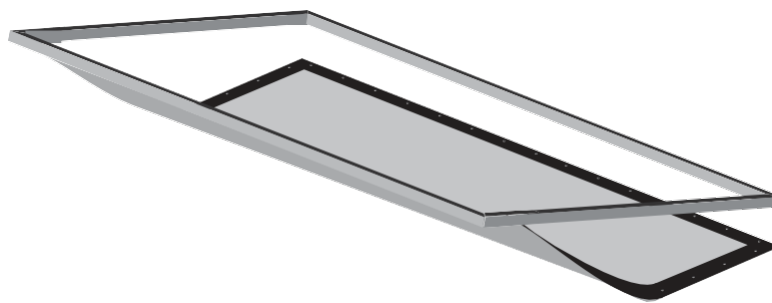

Figure 15: Attaching Remaining Snaps

ATTACHING THE BACKBRACE TO THE FRAME

Note: Professional mounting techniques should be used. Stewart Filmscreen cannot be liable for substandard or faulty installations. Failure to comply with the instructions and guidance contained in this manual may result in voiding your warranty.

1. Lay assembled frame face down on a clean surface.
2. Fit back brace to the outside of the brackets already attached to the frame.
3. Bolt back braces to brackets using the supplied 1/4"-20X3/8" button head bolt (see Figure 16).

Note: Depending on the size of the screen, the number of back braces may vary.

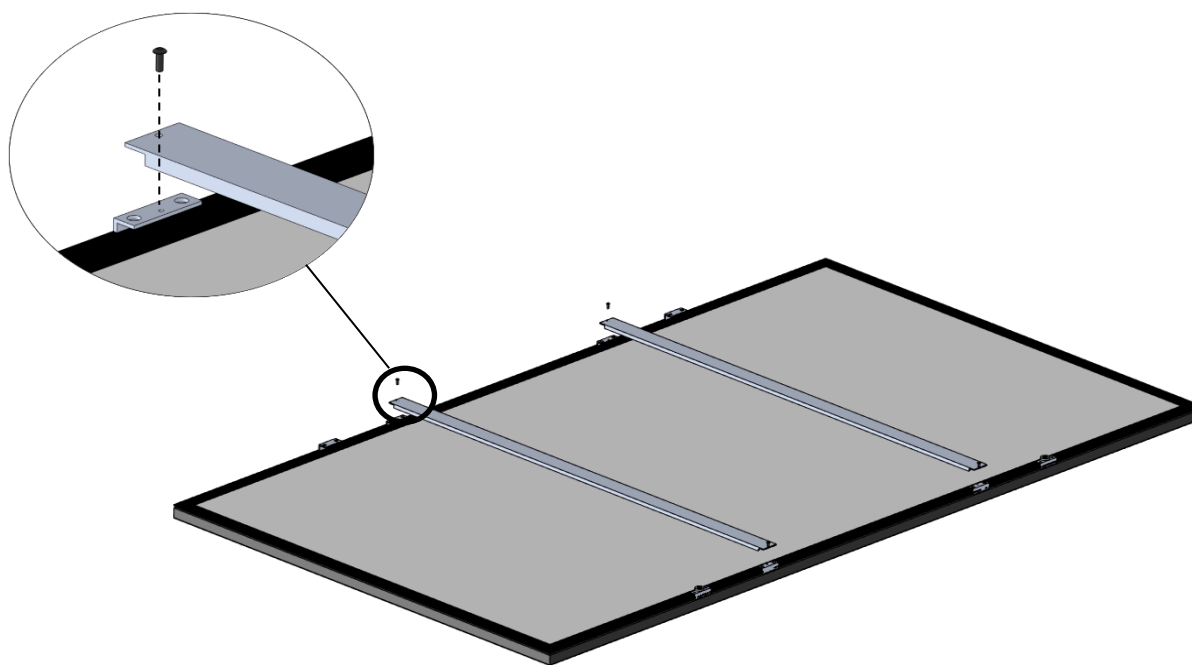

Figure 16: Attaching Back Brace to the Frame

CARING FOR AND CLEANING THE SCREEN

GENERAL MAINTENANCE

With reasonable care, you may expect many years of dependable use of your Stewart projection screen.

FOR VINYL SCREEN MATERIALS ONLY

The surface of your screen is delicate, so we encourage you to keep your screen clean. Special attention to these instructions should be followed when cleaning.

- ▶ Avoid getting any foreign objects on the screen, as cleaning may prove very difficult. It may not be possible to remove scratches, paint, ink, etc.
- ▶ A draftsman-style brush may be used to lightly whisk away any loose dirt or dust particles. (This type of brush is usually available at office supply stores.)
- ▶ For tougher spots, you can make a cleaning solution using a water-based detergent and warm water. To make the solution, mix one-part Simple Green, 409, or another water-based industrial cleaner with three parts warm water. Moisten a clean cotton cloth, or cotton swab with this solution, moisten the stained area, and gently lift off the stain. Never use an aggressive scrubbing action as you could damage the screen surface by removing the optical coating. Re-moisten the area with clean water and dab dry with a clean sponge or cotton cloth. Any residual watermarks will evaporate on their own in a few minutes; do not attempt to manually dry the screen.
- ▶ Contact tech support at Stewart Filmscreen if you have questions about removing difficult spots.

VELUX™ COVERING

CAUTION

- ▶ Do not use any other cleaning materials on the screen.
 - ▶ Do not use chemicals, solvents, or alcohol-based cleaners to clean the screen. Use only commercially available, water-based degreaser or liquid dish soap.
 - ▶ Do not use chemicals, solvents, or liquid cleaners to clean the Velux covering.
 - ▶ Do not fold or crease the screen.
-
- ▶ Use a lint roller to remove particles from the Velux, which is the material covering the frame.
 - ▶ A brush may be used to comb (lift) the nap of the Velux material to eliminate depression marks.

FOR NON-VINYL SCREEN MATERIAL

If you have concerns with one of our non-vinyl Stewart Filmscreen screen materials, contact tech support at Stewart Filmscreen.

ONE (1) YEAR LIMITED WARRANTY

STEWART FILMSCREEN CORPORATION (Stewart) warrants all products to the original purchaser only. Stewart products are guaranteed to be free from defects in materials and workmanship for a period of one (1) year from the date of purchase by the original purchaser or eighteen (18) months from date of manufacture, as defined in the serial number. Additionally, all products must be properly operated and maintained according to Stewart instructions and cannot be damaged due to improper handling or treatment after shipment from the factory. This warranty does not apply to equipment showing evidence of misuse, abuse, or accidental damage, including neglect caused by improper installation (i.e. proximity to hot lights, exposure to extreme heat or cold, exposure to excessive humidity, etc.).

Stewart on-site warranty repair services are not available for this product. Stewart's sole obligation under this warranty shall be to repair or to replace (at Stewart's sole discretion) the defective part of the merchandise. This warranty expressly does not cover any costs of removal, installation, framing, or other costs incidental to replacing the screen or returning it to Stewart. Returns for service should be made to your Stewart dealer. If it is necessary for the dealer to return the screen or part to Stewart, transportation (freight) expenses to and from Stewart are payable by the purchaser. Stewart is not responsible for damage in shipment. To protect against damage or loss in transit, insure the product and prepay all transportation expenses.

This warranty is in lieu of all other warranties, expressed or implied, including warranties as to fitness for use or merchantability. Any implied warranties of fitness for use, or merchantability, that may be mandated by statute or rule of law are limited to the one (1) year warranty period. This warranty gives you specific legal rights, and you may also have other rights which vary from state to state. In no event will Stewart be liable for sums in excess of the purchase price of the product. No liability is assumed by Stewart for expenses or damages resulting from interruption in operation of equipment, or for incidental, direct, or consequential damages of any nature. In the event that there is a defect in materials or workmanship of a Stewart Filmscreen product, you may contact our Customer Service Department at 1161 W Sepulveda Blvd, Torrance, CA 90502- 2797, or call us at 1 (310) 784-5300, or toll free at 1 (800) 762-4999.

IMPORTANT: This warranty shall not be valid and Stewart shall not be bound by this warranty if the product is not operated and maintained in accordance with Stewart's written instructions. Stewart Filmscreen Corporation shall not be liable for any and all consequential damage(s) occasioned by the breach of any written or implied warranty pertaining to the sale of a Stewart Filmscreen product in excess of the purchase price of the product sold.



The Reference for Stunning™

www.StewartFilmscreen.com

1161 W. Sepulveda Blvd., Torrance CA 90502 USA | 1 (800) 762-4999 | Tel: 1 (310) 784-5300 | Fax: 1 (310) 326-6870

Email: TechSupport@StewartFilmscreen.com

©2022 Stewart Filmscreen. Specifications are subject to change without notice.